

FOAM BOARD	1
GLASS, ACRYLIC, MIRROR	4
TAPES, ADHESIVES, & MOUNTING SUPPLIES	7
CONSERVATION TAPES, ADHESIVES	10
MOUNTING TISSUES & ADHESIVE RELEASE BOARDS	12
GLUE & ADHESIVES	15
WIRE PRODUCTS	17
BLADES - MAT CUTTING & GENERAL USE	19
V-NAILS	21
JOINING, POINT DRIVERS, STAPLERS & POINTS	22
PICTURE HANGING HARDWARE & FASTENERS	25
TOUCH-UP & FILLERS	34
FITTING & BACKING SUPPLIES	36
MOUNTING & HANGING SUPPLIES	38
SPECIALTY TOOLS & CLEANING ITEMS	40
KRAFT PAPER & DISPENSERS	44
GALLERY HANGING & DISPLAY PRODUCTS	45
PACKING MATERIALS & SUPPLIES	46
STRETCHER BARS	48
EDUCATIONAL MEDIA	49
MACHINERY	51
MATBOARD	69
INDEX	95



## Terms & Conditions

---

### TERMS:

- Net 15 days.
- Prices subject to change without notice.
- Questions concerning your orders should be addressed to us in writing within 10 days of receipt of order.
- All past due accounts will be shipped C.O.D.
- Shipper's C.O.D. charge will be added to all C.O.D shipments.
- Interest charges of 1.5% will be added to all past due accounts.
- There is a \$30.00 charge on all NSF checks.
- In the event of default of payment, the customer shall pay for all costs of collection, including but not limited to, attorney's fees, court costs, and collection agency fees.

### CREDIT:

- To open your account, please complete our credit application with three trade references and your bank information. Allow 2 to 4 weeks processing to establish an approved credit line. Incomplete credit applications will delay establishment of credit line. Until credit is approved, a check must accompany the order or, with your approval, we will ship C.O.D.

### REMITTANCE:

- Please write your account number and invoice numbers on your check and return with the remittance copy of your invoice.

### SHIPMENTS:

- F.O.B., our warehouse. Shipments will be made by manner requested. If specific instructions are not given, we will use our discretion.
- Courier weight and size limitations:
- Packages can be up to 165" in COMBINED length and girth.
- Packages can be 108" in length
- Packages can be up to 150 lbs.
- Packages that exceed 70 lbs. are subject to additional handling charge.
- Packages with a large size to weight ratio require special pricing using dimensional weight calculations.
- Packages that exceed weight and size limits are subject to additional charges.

### RETURNS:

- No returns will be accepted without prior authorization from an Omega customer service representative. An authorization number will be assigned to you.
- Any merchandise being returned that is not defective or due to our error must be returned freight prepaid by the customer.
- No returns will be authorized after 30 days from receipt of goods.

### DAMAGES:

We are not liable for loss or damage by carrier. In the event of damage, save the merchandise and original packaging so that a proper claim can be filed. Note external carton damage or box shortage on the carrier bill of lading or carrier receipt before signing. Truck and carrier claims must be filed by OMEGA.

---

### OMEGA LOCAL TRUCK DELIVERY AREA:

Call your Omega sales representative for local delivery details for the distribution facility in your area.

- All orders under \$100.00 incur a \$9.00 delivery charge.
- All local deliveries incur the current fuel surcharge.
- If your delivery falls on a holiday, your order will be delivered the same day the following week.
- Please allow at least 48 hours for order processing for all local deliveries.





**Omega Moulding** is a national wholesaler of fine quality picture framing products. We have been providing mouldings of outstanding craftsmanship since 1968. Omega maintains state of the art distribution centers throughout North America in New York, Los Angeles, San Francisco, Atlanta, Chicago, and Toronto. Each facility is stocked with the entire line of over 1600 high quality mouldings available in Length, Chop and Join options. In addition to quality mouldings, Omega offers the largest selection of premium quality Plein Air Gallery Frames in the business, Digital printing machines and consumables, as well as our full line of framing supplies and instructional media for the picture framing industry.

## Quality

The products in this catalog have been selected based on over 75 years of combined business experience between Omega Moulding Company and M&M Framing Supplies, acquired by Omega in 2013. These products have been tested for quality and the suppliers represented in this catalog have been vetted for their reliability and integrity. The framing hardware items sold in this catalog are manufactured using the best quality metals and the highest quality surface plating.

## Pricing

**Pricing for items in this catalog can be found in the current price list available online when you log-in to our website @ [www.omegamoulding.ca](http://www.omegamoulding.ca). Since there are more than 100 different manufacturers represented and many change their pricing at various times of the year, it is BEST to check our constantly updated online catalog for up-to-date pricing.**

## Availability

Availability of some items may be restricted to certain geographic areas by the manufacturer. If the product you wish to buy is not offered in your state we will be happy to suggest a comparable alternative from a different manufacturer.

## Online Ordering

Please be sure to visit the Omega Moulding website at [www.omegamoulding.ca](http://www.omegamoulding.ca) where, as a customer, you can register and instantly use the website as a tool for your business. You can review and select from the complete Omega line, check pricing, view specials, download updated pricing documents, browse closeouts, view your discontinued samples, and use all of the resources we have available to make working with Omega as convenient as possible.

Another great benefit of the Omega Moulding website is Online Ordering. Convenient, easy-to-use and ready at your fingertips 24 hours a day, you can place orders after hours to ensure that you and your customers will receive your items as quickly as possible.

## Ride-Along Program

To make buying your Chops and Framing Supply Items a convenient one-stop shopping experience, we have created the following **Free Freight Program** for you:

- **Supplies accompanying Chop orders of \$75 qualify for Free Purolator ground shipping:**

Your entire order including Framing Supplies will ship free freight when your chop order is valued at \$75 or more.

*\*Oversize items, mats, glass products, foam board, Kraft paper, cardboard corners and gallons of glue are excluded from the free freight ride along due to their bulk and competitive commodity pricing.*

*...and remember "Three and it's Free"; Order three chops and we ship your order for free!*

- **Ride-Along for Length**

The cost difference of adding 10 pounds of Framing Supplies to **RIDE-ALONG** with a Purolator length order will only increase the cost of the freight between \$1.50 and \$3.00 depending on your Purolator delivery zone.

## Buy More & Save More! Supplies & Moulding together adds up to savings!

In addition to the Ride-Along program you are welcome to use the promo code **SC14** and any time you order more than \$350 in supplies you can receive an additional 5% off your length, chop or join order.

*\*Orders with special volume pricing are excluded. Cannot be combined with other promo codes.*

## Save on Supplies with Gallery Frames!

- **Order \$500 in frames, & get 5% off all accompanying supplies. Use Promo Code **GS14****

Omega offers an extensive line of Plein Air style and traditional finished corner Gallery Frames.

Our frames are hand crafted and provide the best quality/price in the industry.

Visit our website to view our Gallery Frames at [www.omegamoulding.ca/Classic/Gallery.htm](http://www.omegamoulding.ca/Classic/Gallery.htm), or request a catalog.

## ENCORE™

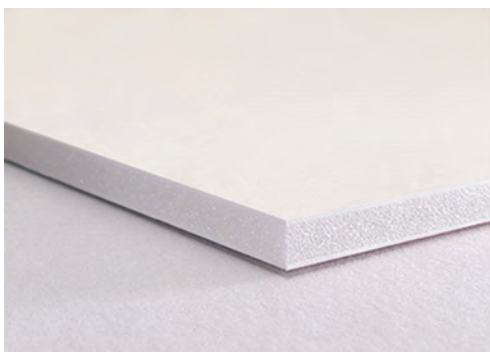

Encore FoamBoard products feature double clay-coat paper surfaces with an ultra-smooth finish and tough-yet-pliable polystyrene cores. Practically weightless, Encore Foam Boards are great for a wide variety of picture framing applications. Encore boards feature a resilient polystyrene memory core that “bounces back” after handling, cutting or mounting.

### ENCORE White Foam Board

Smooth white clay coat board with resilient memory core.

Item #	Size	
RFB2436	3/16" 24 x 36	25 per box
TFB3240	1/8" 32 x 40	25 per box
RFB3240	3/16" 32 x 40	25 per box
TFB4060	1/8" 40 x 60	25 per box
RFB4060	3/16" 40 x 60	25 per box
TFB4896	1/8" 48 x 96	25 per box
RFB4896	3/16" 48 x 96	25 per box
RFB6096	3/16" 60 x 96	20 per box
RFB24896	1/2" 48 x 96	12 per box

### ENCORE Bright White Acid-Free Foam Board

The same archival qualities as Acid-Free Cream, but with bright white acid-free facing papers that create a premium imaging surface for framing projects requiring the whitest substrate. The higher perceived whiteness enhances the maximum color gamut and black density of printed images.

Item #	Size	
WAFB3240	1/8" 32 x 40	
WAF3240	3/16" 32 x 40	
WAFB4060	1/8" 40 x 60	
WAF4060	3/16" 40 x 60	

### ENCORE White 100% Cotton Rag Foam Board

Constructed with pure, naturally white cotton fibers, each facing paper has a pH of 8.2 +/- .5 and a calcium carbonate buffer. Contains no lignin, alum or harsh chemicals.

Item #	Size	
CRFB3240	3/16" 32 x 40	
CRFB4060	3/16" 40 x 60	

### ENCORE Heat-Activated SingleStep Foam Board

Pre-coated pH neutral foam board with heat activated adhesive. Activates at a low 180-degree temperature. A favorite and industry standard for mounting performance and reliability. *Not recommended for resin coated (RC) photographs*

Item #	Size	
SFB2436	3/16" 24 x 36	
SFTB3240	1/8" 32 x 40	
SFB3240	3/16" 32 x 40	
SFB4060	3/16" 40 x 60	
SFB4896	3/16" 48 x 96	

### ENCORE Pressure Sensitive Foam Board

Convenient, all-purpose Foam Board features a pressure-sensitive adhesive coating on one side. Simply peel back the protective liner, roll down your image and smooth from the center to the edges for an easy finish without glues or sprays.

Item #	Size	
PSF2436	3/16" 24 x 36	
PSF3240	3/16" 32 x 40	
PSF4060	3/16" 40 x 60	

### ENCORE MightyCore

When you need a durable, extra-strong performer, Encore® MightyCore® is your best bet. The ultra smooth surface provides excellent adherence. The rigid, rock-solid center makes it especially suitable for large fabricated pieces. The construction of MightyCore helps prevent warping, bowing and twisting and creates a “no preparation” surface for mounting and applications that need a rigid substrate.

Item #	Size	
M143240	1/4" 32 x 40	25 per box
M144060	1/4" 40 x 60	25 per box
M144896	1/4" 48 x 96	12 per box
M124060	1/2" 40 x 60	20 per box
M124896	1/2" 48 x 96	12 per box

### ENCORE (Cream) Acid-Free Foam Board

The professional framer's first choice for a mounting board that's totally acid-free. This product features facing paper with a pH between 7.7 and 8.5. Made with a calcium carbonate buffer that provides many years of protection against pollutants that cause paper to become brittle or yellow with age.

Item #	Size	
AFTB3240	1/8" 32 x 40	25 per box
AFB3240	3/16" 32 x 40	25 per box
AFTB4060	1/8" 40 x 60	25 per box
AFB4060	3/16" 40 x 60	25 per box
AFB4896	3/16" 48 x 96	25 per box

### ENCORE Black-on-Black Acid-Free Foam Board

Featuring the deepest, richest, black paper and foam available, EnCore® Black-On-Black® Foam Board delivers a striking performance with dramatic results. Front to back and edge to edge, Black-On-Black Foam Board remains smooth, flawless and solid black through the core.

Item #	Size	
BBFB3240	3/16" 32 x 40	25 per box
BBFB4060	3/16" 40 x 60	25 per box



Items with this symbol "Ride Along" with your length or chop moulding order at no extra delivery charge.



Items with this symbol are Special Order from the U.S.



# KOOL TACK



**The Original 20-Second  
Drymount Foam Board!**

**Regular Foam Board** · 25 sheets per box

Kool Tack Regular is the most popular low-temp drymount foamboard. Drymount at 150°F to 160°F in 15 to 20 seconds. Safe for most types of photos, posters and prints. Kool Tack is fully reversible and reusable. The adhesive is pH neutral, smooth and non tacky.

Item #	Size
KT3240	32x40 (3/16")
KT3240T	32x40 (1/8")
KT4060	40x60 (3/16")

**Kool Tack Black Foam Board** · 25 sheets per box

Kool Tack Black Foam Board has the same properties as Kool Tack Regular, but with a black substrate and core. Drymount at 150°F to 160°F in 15 to 20 seconds. Kool Tack Black Foam Board is fully reversible and reusable. The adhesive is also pH neutral, smooth and non tacky.

Item #	Size
KTB3240	32x40 (3/16")

**Kool Tack Preserve Ultra** · 25 sheets per box

This archival drymount foamboard is designed for drymounting prints of value. With Preserve, you can drymount a print at 150°F to 155° F for 15 to 20 seconds and at a later date, completely remove the print with a minimal amount of heat.

Item #	Size
KTP3240	32x40 (3/16")

## OMEGA<sup>+</sup>

QUALITY FRAMING PRODUCTS

**Bulk Quantity White Foam Board** 

Quality 3/16" white foam board available in pallet quantity from Omega. Clay-coated board with memory core for large production jobs.

Item #	Size	Qty	
4068BULK	32 x 40	700	Call for current pricing
6068BULK	40 x 60	400	Call for current pricing



**HartBoard by Hartman**

For 25 years, Hartman's foam board product line, HARTBOARD, has been one of the most extensive in the industry. All HartBoard foam board products are non-pillowing. This "memory" board will return to the original thickness when compressed. Hartman's line of foam centered boards are produced using an "environmentally friendly" process.

**Hart Regular Foam Board**

Item #	Size	
HFB2436	3/16" 24 x 36	25 per box
HFB3240	3/16" 32 x 40	25 per box
THFB3240	1/8" 32 x 40	25 per box
HFB4060	3/16" 40 x 60	25 per box
HFB4896	3/16" 48 x 96	25 per box

**• 60 x 120!**

Item #	Size	
HFB60120	3/16" 60 x 120	25 per box

**Hart Heat-Activated Foam Board**

Item #	Size	
HHA2436	3/16" 24 x 36	25 per box
HHA3240	3/16" 32 x 40	25 per box
HHA4060	3/16" 40 x 60	25 per box
HHA4896	3/16" 48 x 96	25 per box

**Hart Acid-Free Foam Board**

Item #	Size	
HAF3240	3/16" 32 x 40	25 per box
HAF4060	3/16" 40 x 60	25 per box
HAF4896	3/16" 48 x 96	25 per box

**Hart Black Acid-Free Foam Board**

Item #	Size	
HBB3240	3/16" 32 x 40	25 per box
HBB4060	3/16" 40 x 60	25 per box

# FOME-COR®

## Fome-Cor

Fome-Cor® Board is the industry's leading paper-faced foam board for more than 40 years. It is comprised of extruded polystyrene foam with clay-coated white or kraft black paper facers, one of which is covered with heat-activated adhesive. Made In USA.

## Fome-Cor Clay Coat Foam Board

Item #	Size	
FBR2436	3/16" 24 x 36	25 per box
FBR3240	3/16" 32 x 40	25 per box
FBRT3240	1/8" 32 x 40	25 per box
FBR4060	3/16" 40 x 60	25 per box
FBR4896	3/16" 48 x 96	25 per box

## Fome-Cor Heat-Activated Foam Board

Item #	Size	
FBS2436	3/16" 24 x 36	25 per box
FBS3240	3/16" 32 x 40	25 per box
FBS4060	3/16" 40 x 60	25 per box
FBS4896	3/16" 48 x 96	25 per box

## Fome-Cor Acid-Free Foam Board

Item #	Size	
FBA3240	3/16" 32 x 40	25 per box
FBA4060	3/16" 40 x 60	25 per box
FBA4896	3/16" 48 x 96	25 per box

## Fome-Cor Black Foam Board

Item #	Size	
FBB3240	3/16" 32 x 40	25 per box
FBB4060	3/16" 40 x 60	25 per box

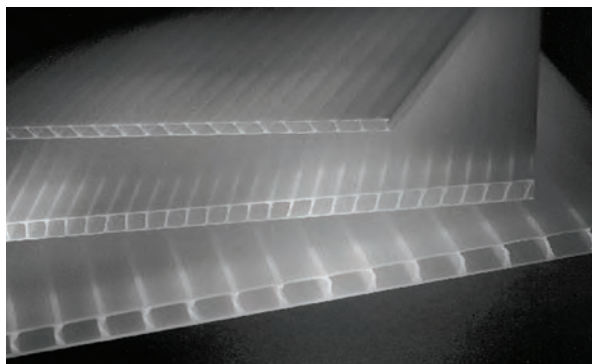

## Omega Archival Polypropylene

Archival fluted polypropylene sheets similar to Coroplast, is acid-free, neutral pH with no dyes or additives. Also available in 6mm thickness by request.

Item #	Description
AFP4060	Archival Polypropylene 40 x 60 4mm
AFP4896	Archival Polypropylene 48 x 96 4mm

# Bainbridge® Artcare™

## Bainbridge Artcare Foam Board

Artcare™ is the only foam board that's truly archival. Using MicroChamber® technology, it absorbs and neutralizes harmful gases and protects artwork well into the future. The opaque, lightly textured surface papers eliminate show-through and feature a soft white color that is suitable for floating applications.

Item #	Size	
8771	32 x 40 1/8"	25 per box
8770	32 x 40 3/16"	25 per box
8771A	40 x 60 1/8"	25 per box
8770A	40 x 60 3/16"	25 per box

## Bainbridge SpeedMount

Makes dry mounting faster than ever, to get through multiple jobs faster, an asset to production framers. SpeedMount works in just seconds and bonds at temperatures as low as 150°.

Item #	Size	
5100B	32 x 40 3/16"	25 per box
5100C	40 x 60 3/16"	25 per box

## Bainbridge SpeedMount Black

Item #	Size	
5101B	32 x 40 3/16"	25 per box



Items with this symbol are Special Order from the U.S.



Items with this symbol "Ride Along" with your length or chop moulding order at no extra delivery charge.

**Clear Select Regular 2mm Glass**

2mm first quality float glass.

Washed, polished, &amp; paper interleaved.

<i>Item #</i>	<i>Size</i>	<i>Lites Per Box</i>
<b>RG810</b>	8 x 10	90 lites/box
<b>RG8511</b>	8 1/2 x 11	77 lites/box
<b>RG1114</b>	11 x 14	47 lites/box
<b>RG1216</b>	12 x 16	38 lites/box
<b>RG1418</b>	14 x 18	29 lites/box
<b>RG1620</b>	16 x 20	23 lites/box
<b>RG1824</b>	18 x 24	17 lites/box
<b>RG2024</b>	20 x 24	15 lites/box
<b>RG2228</b>	22 x 28	12 lites/box
<b>RG2430</b>	24 x 30	10 lites/box
<b>RG2436</b>	24 x 36	8 lites/box
<b>RG2632</b>	26 x 32	9 lites/box
<b>RG2636</b>	26 x 36	8 lites/box
<b>RG2838</b>	28 x 38	7 lites/box
<b>RG3032</b>	30 x 32	8 lites/box
<b>RG3036</b>	30 x 36	7 lites/box
<b>RG3040</b>	30 x 40	6 lites/box
<b>RG3240</b>	32 x 40	6 lites/box
<b>RG3648</b>	36 x 48	4 lites/box
<b>RG4060</b>	40 x 60	3 lites/box
<b>RG4048</b>	40 x 48	4 lites/box

**Clear Select Regular 2.5mm Glass**

2.5mm first quality float glass.

Washed, polished, &amp; paper interleaved.

<i>Item #</i>	<i>Size</i>	<i>Lites Per Box</i>
<b>RGH1114</b>	11 x 14	47 lites/box
<b>RGH1216</b>	12 x 16	38 lites/box
<b>RGH1418</b>	14 x 18	29 lites/box
<b>RGH1620</b>	16 x 20	15 lites/box
<b>RGH2024</b>	20 x 24	15 lites/box
<b>RGH2228</b>	22 x 28	12 lites/box
<b>RGH2436</b>	24 x 36	8 lites/box
<b>RGH3240</b>	32 x 40	6 lites/box
<b>RGH3648</b>	36 x 48	4 lites/box
<b>RGH4060</b>	40 x 60	3 lites/box

**Non-Glare 2mm Glass**

2mm single-side micro-etched non-glare glass for highest clarity. Washed, polished, &amp; paper interleaved.

<i>Item #</i>	<i>Size</i>	<i>Lites Per Box</i>
<b>NG1620</b>	16 x 20	23 lites/box
<b>NG2024</b>	20 x 24	15 lites/box
<b>NG2228</b>	22 x 28	12 lites/box
<b>NG2430</b>	24 x 30	10 lites/box
<b>NG2436</b>	24 x 36	8 lites/box
<b>NG3240</b>	32 x 40	6 lites/box
<b>NG3648</b>	36 x 48	4 lites/box
<b>NG4060</b>	40 x 60	3 lites/box

artglass

**Artglass Water White AR UV Glass**

State-of-the-art technology allows Artglass™ to have the lowest visible light reflection, precisely tuned for unparalleled clarity and color correctness.

- Reflection free • Neutral reflected color
- True color transparency and superior clarity of image
- High durability coating, suited for outdoor applications
- Easy to clean, handle, & store.
- UV70 & UV92 are coated on both sides; cut any side.

**Artglass Water White UV70****70% UV Protection • <1% Reflection • 2mm***Item #      Size (Lites Per Box)*

<b>AG1620</b>	<b>16x20 (12 lites)</b>
<b>AG2436</b>	<b>24x36 (4 lites)</b>
<b>AG3240</b>	<b>32x40 (3 lites)</b>
<b>AG3648</b>	<b>36x48 (2 lites)</b>
<b>AG4060</b>	<b>40x60 (2 lites)</b>

**Artglass Water White UV92****92% UV Protection • <1% Reflection • 2mm***Item #      Size (Lites Per Box)*

<b>AG1620UV</b>	<b>16x20 (16 lites)</b>
<b>AG2436UV</b>	<b>24x36 (6 lites)</b>
<b>AG3240UV</b>	<b>32x40 (4 lites)</b>
<b>AG3648UV</b>	<b>36x48 (3 lites)</b>
<b>AG4060UV</b>	<b>40x60 (2 lites)</b>
<b>AG4864UV</b>	<b>48x64 (2 lites)</b>

**Artglass UV99****99% UV Protection • <1% Reflection • 2mm***Item #      Size (Lites Per Box)*

<b>ARC91620</b>	<b>16x20 (16 lites)</b>
<b>ARC92024</b>	<b>20x24 (10 lites)</b>
<b>ARC92228</b>	<b>22x28 (8 lites)</b>
<b>ARC92436</b>	<b>24x36 (6 lites)</b>
<b>ARC93240</b>	<b>32x40 (4 lites)</b>
<b>ARC93648</b>	<b>36x48 (3 lites)</b>
<b>ARC94060</b>	<b>40x60 (2 lites)</b>

artglass **PRESERVATION CLEAR****Artglass Preservation Clear™**

Preservation Clear UV 99™ provides UV protection by blocking out 99% of harmful rays thus helping prevent the treasured keepsake from fading. Preservation Clear UV 99™ is your great choice for picture framing. Preservation Clear has no "orange peel" surface distortion and has a neutral color that won't effect the color of your artwork.

*Item #      Size (Lites Per Box)*

<b>APC91620</b>	<b>16x20 (23 lites)</b>
<b>APC92024</b>	<b>20x24 (15 lites)</b>
<b>APC92228</b>	<b>22x28 (12 lites)</b>
<b>APC92436</b>	<b>24x36 (8 lites)</b>
<b>APC93240</b>	<b>32x40 (6 lites)</b>
<b>APC93648</b>	<b>36x48 (4 lites)</b>
<b>APC94060</b>	<b>40x60 (2 lites)</b>



Items with this symbol "Ride Along" with your length or chop moulding order at no extra delivery charge.



Guaranteed to be defect free, ACRYLITE® acrylic sheet framing products are manufactured to more stringent specifications than standard acrylic sheet, eliminating dirt and blemishes that could potentially produce imperfections when viewing framed artwork. Our selection of Acrylite picture framing products include acrylics with UV filtering properties, non-glare options or with an abrasion and chemical resistant coating for ultimate protection.

**Acrylite Clear Acrylic**

.06 to .118 gauge framing grade acrylic FF3.

Item #      Size, Gauge (Coating)

- PXC3240 32x40 .118 (TE mask)
- PXC4060 40x60 .118 (TE mask)
- PXCP4060 40x60 .118 (TE mask)
- PX9606F 48x96 .06 (TE mask)
- PX9608F 48x96 .08 (TE mask)
- PXC4896 48x96 .118 (TE mask)
- PXCP4896 48x96 .118 (TE mask)
- PX9698FC 48x96 .098 (TE mask)
- PX6096F 60x96 .118 (TE mask)

**Acrylite UV Protection Acrylic**

.098 to .118 gauge 98% UV filtering 92% transmission picture framing OP3 acrylic. Paper mask coated.

Item #      Size, Description

- PXUV4060 40x60 .118
- PXU9698P 48x96 .098
- PXUV4896 48x96 .118

**Acrylite Non-Glare**

Non-glare & Non-glare with UV protection

**Acrylite Non-Glare Acrylic**

.098 to .118 gauge non-glare picture framing acrylic. TE masking.

Item #      Size, Gauge, Description

- PXNG9698 48x96 .098 FF3 P99
- PXNG4896 48x96 .118 FF3 P99

**Acrylite Non-Glare UV Protection Acrylic**

.098 to .118 gauge non-glare 98% UV protection 92% transmission picture framing acrylic. TE masking.

Item #      Size, Description

- PXUVNG18 48x96 .118 P99 OP3
- PXUVNG98 48x96 .098 P99 OP3

**Cut-To-Size Acrylite Acrylic**

Order any custom size precut from Omega. Convenient for large quantity jobs and large sizes, saving time and trouble and ensuring precision.

Item #      Description

- 3501 .098 Clear Acrylic (TE Mask)
- 3500 .118 Clear Acrylic (TE Mask)
- 3502 .118 Non Glare Acrylic (TE Mask)
- 3504 .118 UV Non Glare OP3 P99 (Paper Mask)
- 3506 .118 Clear (oversize, exceeding 48"x96")
- 3503UF .118 UV Clear OP3 (Paper Mask)
- 3508 .118 Clear Acrylic (Paper Mask)
- 3509 .098 Non Glare (TE Mask)
- 3510 .06 Clear Acrylic (TE Mask)
- 3511 .098 UV Clear Acrylic



**VARI GUARD™**

The Best Protection for Your Light-Sensitive Artifacts



> For more information on VariGuard Smart Glass, call Omega today or visit [www.museumglazing.com](http://www.museumglazing.com)

**VariGuard Smart Glass**

VariGuard SmartGlass™ is the first and only display panel that offers a wide range of visible light transmission, instant switching between dark and clear states, and 99% UV-blocking at all times. Based on patented SPD light-control technology developed by Research Frontiers, VariGuard display panels optimally protect artifacts by limiting their light-exposure only to those times when people are viewing them.

- Laminated glazing for added strength and security
- Wide range of visible light transmission
- Instant switching between light-blocking and light-transmissive states
- Light-blocking default state; no power required for maximum protection
- Nominal power draw in light-transmissive state
- 99% UV blocking at all times
- Optional features: Anti-Reflection, IR-Rejection, Ballistic/Blast-Resistance



Items with this symbol "Ride Along" with your length or chop moulding order at no extra delivery charge.



Items with this symbol are Special Order from the U.S.



Quality Mirror Products by **OMEGA**



**Premium Beveled Mirrors**

All mirrors are washed, polished, and ready to frame. Individually boxed with corner protectors. 1/4" mirror with 1/4" bevel edge and sealed back.

*Item #     Mirror Size*

- BVM810**     8 x 10
- BVM1620**   16 x 20
- BVM2024**   20 x 24
- BVM2228**   22 x 28
- BVM2430**   24 x 30
- BVM2436**   24 x 36
- BVM3040**   30 x 40
- BVM3248**   32 x 48
- BVM3648**   36 x 48
- BVM1860**   18 x 60
- BVM2460**   24 x 60

**Flat Mirrors**

1/8" mirror sheets that you can cut to size for custom jobs. Mirrors are washed, polished and individually packed. Mirrors are painted and sealed on back.

*Item #     Mirror Size*

- RM3240**     32 x 40
- RM3648**     36 x 48
- RM4060**     40 x 60



**210 Brand Plastic Cleaner**

A must-have for cleaning and treating acrylic prior to framing. Cleans fast and leaves a protective coating that resists fingerprints, gives materials a lustrous look. Contains a powerful anti-static agent that when used in combination with the 4" Anti-Static Brush virtually eliminates static charge. 

*Item #     Size*

- 4520A**   14 oz. can



**210 Plastic Scratch Remover**

210 Plus Plastic Scratch Remover will remove all but the deepest surface scratches. Restores a brilliant finish to formerly dull surfaces. Anti-static and anti-fog. Use on Plexiglas®, Acrylite® and similar products. *15oz. bottle* 

*Item #     Size*

- 4521**   15 oz. bottle



**Sprayway Plastic Cleaner**

Formulated for use on many surfaces including acrylics, Plexiglas, glass, polycarbonates, chrome, and Formica. Repels finger smudges, dirt and dust. Leaves acrylic Anti-static, anti-fog. Fast-drying, non-streaking. Contains no chemicals or abrasives. *19 oz. can* 

*Item #     Size*

- SP848**   19 oz. can



**Sprayway Glass Cleaner**

The World's Best Glass Cleaner. In addition to framing, it is excellent for windows, mirrors, windshields and other glass surfaces. Dissolves dirt, grease, grit, and grime. Guaranteed to leave no film or streaking. Contains perfume-grade alcohol for best performance. Ammonia-free. *19 oz. can* 

*Item #     Size*

- SP50**   19 oz. can

**NOVUS**



**Novus #1 Acrylic Cleaner**

Gently cleans all plastics without scratching. Leaves a lustrous shine that resists fogging, repels dust, eliminates static and resists fingerprints. Contains no abrasives or harsh chemicals. Leaves a smooth, clean, greaseless shine. *8oz. bottle* 

*Item #     Size*

- NPC10**   8 oz. bottle



**Novus #2 Scratch Remover**

Removes fine scratches, haziness and abrasions from most plastics. With repeated use, NOVUS No. 2 restores faded and discolored plastics. Removes the damage instead of filling it in. Buffs out quickly. After restoring, seals with a coat of polish. *8oz. bottle* 

*Item #     Size*

- NPC20**   8 oz. bottle



**Novus #3 Deep Scratch Repair**

Removes heavy scratches and abrasions from most acrylic surfaces. Use when damage is too severe to be restored with NOVUS No. 2 polish. Requires use of NOVUS No. 2 for final finishing. Not recommended for use on coated plastics. *8oz. bottle* 

*Item #     Size*

- NPC30**   8 oz. bottle



**Novus Acrylic Cleaner Starter Kit** 

*2oz. Polish 1 - Clean & Shine*  
*2oz. Polish 2 - Fine Scratch Remover*  
*2oz. Polish 3 - Deep Scratch Repair*  
Comes with 2 NOVUS Polish Mates cloths and product brochure.

*Item #     Description*

- NPC7136**   Novus Starter Kit



**Ultra Lite Glass & Plastic Cleaner**

No alcohol, No ammonia. One 8 oz. Ultra Lite Concentrated Glass & Plastic Cleaner makes 1 gallon and is guaranteed not to streak when diluted with distilled water.

*Item #     Description*

- 590885**   8 oz. bottle 



**TRU VUE**

**TruVue Premium Clean Glass Cleaner** 

Ammonia-free, safe for any picture framing glass. Soap free, will not lather or foam. Easy to use; static-free deionized formula repels dust.

*Item #     Size*

- 2069**   26 oz. bottle
- 2068**   1 gallon bottle



# 3M ATG

## 3M 924 ATG

3M® 924 is a medium-tack ATG, ideal for bonding a wide variety of materials such as papers, wood, foam board, and plastics. Applications include mounting picture frame mat boards and dust covers. For use with 3M Scotch® (and similar type) ATG Adhesive Applicators. 

*Item #      Size*

**3M924146** 1/4" x 36 yds

**3M92412** 1/2" x 36 yds

**3M92460** 1/2" x 60 yds

*Item #      Size*

**3M92434** 3/4" x 36 yds

**3M92436** 3/4" x 60 yds

## 3M 969 ATG

3M® 969 is a **high tack** adhesive transfer tape, ideal for applications requiring high bond strength, high shear strength and high temperature performance. For use with 3M Scotch® (and similar type) ATG Adhesive Applicators. 

*Item #      Size*

**3M96918** 1/2" x 18 yds

**3M96936** 1/2" x 36 yds

## 3M 908 Gold Acid Free ATG

3M® 908 is pressure sensitive acid-free adhesive. It is ideal for bonding acid-free boards and will not yellow, become brittle or lose adhesion. Can be used with 3M Scotch® (and similar type) ATG Applicators. 3M® 908 has a pH between 7.0 and 8.5. 

*Item #      Size*

**3M908146** 1/4" x 36 yds

**3M90812** 1/2" x 36 yds

*Item #      Size*

**3M90834** 3/4" x 36 yds

## 3M 987 ATG

3M™ 987 is a general purpose ATG for holding many paper, foils, films, and various foams. For use with 3M Scotch® (and similar type) ATG Adhesive Applicators. 

*Item #      Size*

**3M98712** 1/2" x 36 yds

**3M98760** 1/2" x 60 yds

*Item #      Size*

**3M98734** 3/4" x 36 yds

**3M98736** 3/4" x 60 yds



## 3M 700 ATG Applicator Gun

The 3M® 700 Applicator Gun is designed to hold all ATG rolls 1/2" - 3/4" wide and up to 60 yds. Covered gears minimize applicator jams and transparent cover shows remaining tape. Easy trigger controls application of tape. Applies ATG tape while simultaneously removing and rewinding the liner.

*Item #      Description*

**3M700** #700 Dispenser



## 3M 714 ATG Applicator Gun

The 3M® 714 Applicator Gun is designed specifically to hold 1/4" ATG rolls up to 60 yds. Covered gears minimize applicator jams. Transparent cover shows remaining tape.

*Item #      Description*

**3M714** #714 Dispenser



## Omega True Blue Applicator Gun

The True Blue ATG Applicator Gun is a sturdy general-purpose frameshop workhorse. Holds rolls up to 36 yards and up to 3/4" width. 

*Item #      Description*

**T100** Blue ATG Applicator Gun

# ΩMEGA<sup>+</sup>

QUALITY FRAMING PRODUCTS



## Omega ATG

Omega ATG is a quality acrylic general-use pressure sensitive adhesive on a strong acrylic paper liner, designed to fit 3M Scotch® (and similar type) ATG Adhesive Applicators.

## Omega Regular ATG

2 mil • Medium Tack • Instant, permanent mounting  
Comparable properties to 3M 924 ATG. 

*Item #      Size*

**ATG1236** 1/2" x 36 yds

**ATG1260** 1/2" x 60 yds

## Omega SuperTack ATG

5 mil • High Tack • Instant, permanent mounting  
Comparable properties to 3M 969 ATG. 

*Item #      Size*

**ATGST36** 1/2" x 36 yds



Items with this symbol "Ride Along" with your length or chop moulding order at no extra delivery charge.



Items with this symbol are Special Order from the U.S.





**3M Scotch 810 Magic Tape**

Mend it, seal it and secure it with this permanent transparent tape. Non-yellowing tape disappears when applied, and stays invisible over time. Though not for use on artwork, Scotch 810 tape has a variety of uses throughout the frame shop.  
3/4" 72 yard roll

Item # \_\_\_\_\_ Size \_\_\_\_\_

**1081** 3/4" x 72 yds

**3M Scotch 811 Removable Tape**

Temporarily secures mats and other items. Allows for repositioning without tearing. Easily removed and ideal for decorative mats.  
3/4" 72 yard roll

Item # \_\_\_\_\_ Size \_\_\_\_\_

**3M81134** 3/4" x 72 yds



**Black Flocked Tape**

Omega's exclusive flocked black tape is ideal for lining shadowboxes. Great for production work and easy to use, this high quality flexible felt tape adheres strongly to fabric, wood, and paper. Easy to cut, peel, and position. Comes in 36 ft. rolls in widths of 1", 1½", and 2". 3" core

Item # \_\_\_\_\_ Size \_\_\_\_\_

**T108** 1" x 36 ft.

**T109** 1½" x 36 ft.

**T110** 2" x 36 ft.



**Black Gaffers Tape**

Great for lining shadowbox and mirror frames, project construction canvas edges and more! 2" wide flexible fabric tape with strong adhesion to fabric, wood, and paper.

Item # \_\_\_\_\_ Size \_\_\_\_\_

**T113** 2" x 60 yds



**Black Mirror Tape**

Black tape to adhere inside rabbet to mask reflection of wood when framing mirrors.

Item # \_\_\_\_\_ Size \_\_\_\_\_

**T107** 1/4" x 54 yds



**Flat Back Tapes**

High quality flatback tape with natural rubber adhesive for good instant adhesion. Use for reinforcing packaging, splicing foamboard, or sealing backings. Easy tear, pressure sensitive. Available in White (1") and Kraft (¾", 1", 1 ½", 2") 3" Core • 60 yard rolls.

Item # \_\_\_\_\_ Size \_\_\_\_\_ Color \_\_\_\_\_

**T105** 1" x 60 yds White

**T104** 2" x 60 yds Kraft



**Box Sealing Tape**

Commercial-grade packaging tape is ideal for general-purpose packaging applications. Can be used in handheld tape guns for easy dispensing. Meets U.S. Postal regulations. 3" Core • 60 yard rolls.

Item # \_\_\_\_\_ Size \_\_\_\_\_

**T101** 2" x 110 yds



**Filament Tape**

Pressure-sensitive tape used for several packaging functions such as closing corrugated fiberboard boxes, reinforcing packages, bundling items, etc. Polyester film and fiberglass filaments embedded to add high tensile strength. Meets U.S. Postal regulations. 3" core.

Item # \_\_\_\_\_ Size \_\_\_\_\_

**2051** ¾" x 60 yds



**Framer's Tape II** 

**Framer's Tape II** is an acid-free pressure sensitive tape used for hinging artwork and matboards. Highly regarded throughout the industry, this tape is thick and strong and can be removed with minimal heat without leaving adhesive residue. pH neutral, non-yellowing. 3" Core • 60 yard rolls.

Item #	Size • Description
T111	3/4" x 60 yds • Framers Tape II
T112	1" x 60 yds • Framers Tape II



**Stitchery Tape** 

**Stitchery Tape** is acid-free & solvent-free double-sided tape for stitchery mounting. It is safe for fabric; silk, linen, velvet and more. Adhesive will not bleed through or damage fabric. 3" Core • 1 1/2" x 36 yard roll.

Item #	Size • Description
T114	1 1/2" x 36 yds • Stitchery Tape



**Natural Crepe Masking Tape** 

Quality natural crepe masking tape in 3/4" & 1" widths. 3" Core • 60 yard rolls.

Item #	Size
T102	3/4" x 60 yds
T103	1" x 60 yds



**Black Masking Tape** 

Quality black crepe masking tape in 3/4" and 1" widths. 3" Core • 60 yard rolls.

Item #	Size
T106	3/4" x 60 yds



**White Artist Tape** 

This quality white flatback artist tape is pH neutral, allowing a wider range of use than utility grade flatback rubber adhesive tapes. Great for splicing foamboards, reinforcing fillets to boards, and more. 1/2" & 3/4" wide rolls. 3" Core • 60 yard rolls.

Item #	Size
4375E	1/2" x 60 yds
4375B	3/4" x 60 yds
4375C	1" x 60 yds



**Acid Free Plastic Framing Tape** 

Plastic tape made specifically for the acid-free matting and hinging of artwork. Will not yellow or stain artwork, deteriorate or leave residue. Strong adhesion to paper, mat boards, and foam board.

Item #	Size
4390	3/4" x 60 yds
4391	1" x 60 yds
4392	2" x 60 yds



Items with this symbol "Ride Along" with your length or chop moulding order at no extra delivery charge.



Items with this symbol are Special Order from the U.S.



## Filmoplast P-90

Filmoplast P-90 is a self-adhesive white paper tape perfect for hinging artwork. The long-fibered material makes it durable and tear-resistant and provides a secure means to hinge even larger artwork.

## Filmoplast P-90 Plus

P-90 Plus is specifically designed for fine art hinging. The adhesive used is a refined version of the original providing better initial as well as final bond strength while retaining the same stable aging characteristics. Both the adhesive and paper are buffered (pH 8.7 aged) so the tape remains acid-free for decades.

*Item # Description*

**N25223 P90** • ¾" x 164ft.

**N6018639 P90 Plus** • ¾" x 164ft.



## Filmoplast SH

When the application calls for exceptional strength Filmoplast SH is the answer. Made from an very fine threaded white linen fabric this tape is coated with a high tack acrylic adhesive that bonds well to a variety of surfaces. Filmoplast SH can also be used in conjunction with Filmoplast P 90 to create a high strength art hinge. In this application the Filmoplast SH is used as the cross piece attached to the backing board and Filmoplast P 90 holds the art.

*Item # Size*

**N25124** 1¼" x 82 ft.



## Lineco Gumm Paper Hinging Tape

The high tensile strength of this quality, water activated hinging tape will support all but the heaviest works of art. The paper is acid-free with a calcium carbonate buffer and a pH of 8.5. The neutral pH adhesive has excellent tack to hold firmly without slipping or "creeping".

*Item # Size*

**1710** 1" x 130 ft.

## Lineco Abaca.sa Hinging Tape

Abaca.sa self-hinging tape incorporates the strength and supple nature of Abaca paper (manila hemp), along with a very strong acrylic adhesive that is permanent and non-yellowing. Gummed tapes are risky to use with Giclee inkjet prints because of their water sensitivity. In these cases a self-adhesive tape is a much safer alternative. Abaca.sa is strong enough to hold large digital prints, and supple enough to adhere to the print without distorting. Abaca paper is acid-free, biodegradable, and comes from a self-sustaining plant.

*Item # Size*

**L5330754** 7/8" x 150 ft.

## Lineco Mulberry Hinging Tape

High quality, strong, weight (52 gsm), Japanese paper offered in convenient rolls of 1" x 100 ft. For use with wheat/rice starch or methyl cellulose homemade paste. For a non-adhesive mousing method, paper slings or paper photo corners are simple to make and adhere with archival tapes.

*Item # Size*

**L5330756** 1" x 100 ft.



## Lineco Self-Adhesive Hinging Tissue

This pressure sensitive, mounting/hinging tissue is a fine, long fibered tissue with an archival quality pressure sensitive acrylic adhesive that is permanent and non-yellowing. Ideal for hinging translucent art such as Japanese paper, papyrus, and other light weight art because it won't show through.

*Item # Size*

**L5330125** 1" x 35 ft.

**1720** 1" x 98 ft. 



## Lineco Document Repair Tape

This very thin and extremely transparent pressure sensitive document repair tape is non-yellowing, removable with solvents, and has a neutral pH. To use, dispense a length of tissue, place over the tear, and burnish with a bone folder. Working the adhesive into the tear causes the adhesive to strengthen the tear as well as cover and support the area around the tear. It has been thoroughly tested and approved by numerous government agencies and is a favorite of both conservators and collectors.

*Item # Size*

**L9010198** 1" x 35 ft.

**L5330198** 1" x 98 ft.



## Lineco Self-Adhesive Linen Hinging Tape

Lineco's Self Adhesive Linen Hinging Tape is an excellent choice for hinging window mats and photos. It's a non-yellowing, pressure sensitive adhesive. Coated with a neutral pH acrylic adhesive of archival quality, the tape has a high thread count and a release liner paper. The linen is a favorite for hinging window mats to backboard or attaching art. The very fine linen cloth is flexible yet strong.

*Item # Size*

**L5330115** 1¼" x 35 ft.

**1715** 1¼" x 150 ft. 



## Lineco Gummed Linen Hinging Tape

This water activated tape, with 65/55 thread count fabric, provides superior strength for hinging, mounting or repair applications. The neutral pH adhesive has high tack, lay flat properties that make it a favorite for hinging mats and heavy pieces. Available in 1" x 150' or 1" x 300' rolls.

*Item # Size*

**L5331025** 1" x 30 ft.

**L5331050** 1" x 150 ft. 



## Lineco Transparent Mending Tissue

This very thin and extremely transparent pressure sensitive archival mending tissue is non-yellowing, removable with solvents and has a neutral pH. To use, dispense a length of tissue, place over the tear and burnish with a bone folder. Working the adhesive into the tear causes the adhesive to strengthen the tear as well as cover and support the area around the tear.

*Item # Size*

**1740** ½" x 50 ft. 





## Lineco Archival Mounting Corners

Pressure sensitive Archival Mounting Corners virtually disappear on the page, yet hold your artwork firmly in place. See-thru Archival Corners simply press into place and feature a safe acrylic adhesive backing. Use in conservation mounting applications of photographs, prints, and other 2-dimensional artwork.

Item #	Description	Qty.
1704	5/8" Photo Corner	500
1705	1/2" Photo Corner	240
1706	1 3/8" Mounting Corner	240
L5330034	1 1/4" Standard Poly Corner	250
L5330035	1 1/4" Full View Poly Corner	250
5330038M	1 1/4" Slimline Poly Corner	72
L5330036	3" Standard Poly Corner	100
L5330037	3" Full View Poly Corner	100



## Lineco Archival Mounting Strips

Use these mounting strips for safe, hingeless mounting of artwork to mats. Made from conservation quality Archival Polyester and acid-free paper with a self adhesive backing strip. Simply position the print or photograph in place and adhere strips to the mat. No adhesive ever comes in contact with the artwork. Instead, the art is cradled by inert archival polyester and is ready to be framed.

Item #	Description	Qty.
L5334015	1"x4" Archival Strips	60
1701	1"x12" Archival Strips	60



## Lineco pH Testing Pen

Distinguish between safe alkaline paper and board, and unsafe acidic paper and board. The chlorophenol red indicator solution turns a definite purple color on any paper with a pH of 6.5 or higher.

Item #	Description
1130	Lineco pH Testing Pen



## Lineco Frame Sealing Tapes

The white and gray frame sealing tape is designed specifically to seal backing board to frames. This pressure sensitive tape attaches firmly to almost any surface and conforms well to most surface irregularities. Manufactured from Lineco's exclusive Perma/Seal label stock with a foil layer, a non-yellowing, permanent acrylic adhesive and coated to match Lineco's Frame Backing Paper (sold separately). Also provides an effective barrier for the rabbets of wood frames.

Item #	Description
--------	-------------

L3870151 1 1/4" x 85 ft. • Gray

1731 1 1/4" x 85 ft. • White

## Copper I-Film Corrosion Intercept

Features a polyethylene embedded with a copper matrix which is coated with an acrylic adhesive. It is flexible, strong and puncture resistant for easy application. Helps retard acids, corrosive gases, and resists mold and mildew. Strong adhesive sticks to raw wood.

Item #	Description
--------	-------------

L0342000 1 1/4" x 85 ft. • Copper



## Lineco Neutral pH Adhesive

A white, neutral pH adhesive made of archival polyvinyl acetate (PVA), Lineco Neutral pH Adhesive is ideal for artistic creations such as collages and bookbinding, and for adhering mats and objects within a frame. This adhesive has excellent "lay flat" properties, dries clear and fast, it won't become brittle with age, and it's remoistenable with water.

Item #	Description
--------	-------------

1745 8 fluid oz. Bottle

## Lineco Methyl Cellulose Adhesive

A neutral pH, water reversible adhesive that dries clear. Use for repair, gluing end sheets and general archival adhesive applications.

Item #	Description
--------	-------------

L7931001 1.5 oz. bottle

## Lineco Wheat Starch Adhesive

A very carefully purified, uncooked food-grade wheat starch. When cooked, it makes a superior smooth wheat paste adhesive.

Item #	Description
--------	-------------

L6151002 2 oz. bottle

## Lineco Rice Starch Adhesive

Similar to wheat starch, but it yields a lighter, thinner starch adhesive paste after cooking.

Item #	Description
--------	-------------

L6151502 2 oz. bottle



## Lineco Volara Foam Rabbet Tape

This inert, .0313" thick foam tape features an aggressive acrylic adhesive for lining frame rabbets. Protects canvas transfers, digital media and other forms of art by providing a cushion.

Item #	Description
--------	-------------

L0181436 1/4" x 36 yds./0.0313 thick



## Lineco Frame Backer Paper

Use this attractive paper to add value and differentiate your museum quality framing jobs. This acid-free buffered paper won't harm the art and won't puncture like everyday brown or black kraft paper. Moderate porosity allows the frame package to breathe. 40 lb. paper weight. 36" x 300 ft. roll

Item #	Size
--------	------

L6130037 36" x 300 ft. Roll



## Lineco Tyvek Frame Backing Paper

A unique frame backing material that is acid-free and contains no damaging chemicals that can affect framed artwork. Tyvek is easily cut and worked like traditional paper frame backing material, yet is puncture and moisture resistant and won't attract insects. ( White, 36" x 70 yd. roll)

Item #	Size
--------	------

1723 36" x 70 yd. Roll



## D&K Expression Fusion 4000 Acid-Free Dry Mounting Tissue

Fusion 4000 Adhesive is an ultra-clear, removable, thermal-activated, 100% inert, pure adhesive film that can conform around free-form shapes. Can be overlapped. Great for mounting lithographs, newsprint, photographs (fiber-based and RC), photostats, art papers, engravings, silks, canvas and foils; also ideal for textured surfaces and fabrics. Fusion 4000 is acid-free; mounted work can be removed by reheating, with extreme care especially with delicate media. Adhesive activates at 170 degrees Fahrenheit. Bonds in under 2 minutes. 

Item #	Size
BF356	24" x 30 yds.
BF358	40.5" x 30 yds.

## D&K Expression ColorMount Dry Mounting Tissue

Colormount Dry Mounting Tissue is a porous tissue coated on both sides with a low temperature adhesive that bonds while hot. Permanently bonds at 185° Fahrenheit. Specially formulated for permanent, low-temperature dry-mounting of RC photographs. It's also an excellent general-purpose adhesive for most other mounting applications, including slick poster materials, blueprints, lithographs and other smooth artwork. Works well with almost all mounting substrates: cardboard, foam boards, Masonite, aluminum and Plexiglas. 

Item #	Size
BF614	24.5" x 50 yds.
BF618	40.5" x 50 yds.
BF622	48.5" x 50 yds.



## D&K RagMount Dry Mounting Tissue

Ragmount® Tissue (Film) is a 100% breathable tissue for today's modern digital prints. The benefit of this breakthrough tissue is that it prevents air from becoming trapped inside the film that can cause bubbles. The bond is very secure and safe for long-term mounting. The adhesive is acid free and solvent free, applied on 100% cotton rag tissue.

Item #	Description
BFA435	Ragmount 24.5" x 150'
BFA436	Ragmount 40.5" x 150'



## D&K Buffermount Dry Mounting Tissue

BufferMount® is a very versatile and safe acid-free adhesive tissue. It is coated on both sides with a low-temperature (170° F), inert acrylic adhesive that melts during heating, bonds as it cools and is removable when reheated. 

Item #	Description
3036A	Buffermount 24.5" x 90'
3037A	Buffermount 40.5" x 90'

## D&K Double-Sided Release Paper

High quality non-stick silicone paper, evenly coated on both sides, to prevent adhesion and reduce residue build up on the heat press platen. The heavy weight 60 lb paper performs well as a protective overlay for maintaining the even texture of your mounted subject matter and can be used multiple times due to its strength and coating. 

Item #	Description
BF929	26" x 60' Roll
BF934	42" x 90' Roll

## D&K Single-Sided Release Paper

Release paper silicone coated on one side for use as a protective overlay when dry mounting in a heat or vacuum press. Single sided release paper is used as a carrier sheet when tissues are being laminated and as a protective layer when applying localized heat using a tacking iron. 

Item #	Description
BFA490	42" x 90' Roll

## D&K Silicone Coated Release Board

Coated with silicone on each side, Bienfang release boards protect your projects during heat mounting and keep adhesive residues off of the press platen. Sturdy and reusable, these boards flatten rolled papers while securing your materials while mounting. 32"x40", 5 boards per pack.

Item #	Description
BF938	5 ct. 32" x 40" Release Boards



## VistaMount Dry Mounting Tissue

VistaMount is a terrific all purpose dry mounting tissue, as well as a budget-friendly staple for your frameshop. VistaMount is a white heat activated tissue with a buffered paper core that provides a strong permanent bond. Adhesive activates at a cool 170-190 degrees in 1-2 minutes.

Item #	Description
2071A	VistaMount 24.5" x 150'
2071B	VistaMount 40.5" x 150'

## Flobond Acid-Free Dry Mounting Film

Flobond is 100% adhesive, having no core tissue whatsoever. This allows for great ease of use as the adhesive melts seamlessly onto the substrate, the material can be overlapped or patched. This is a pH neutral adhesive, and can be reversed by reheating. Bonds at 175-200 degrees Fahrenheit in 1-2 minutes. Great for mounting a variety of papers and flexible materials. 90' ft. rolls.

Item #	Description
1441	FloBond 24.5" x 90'
1443	FloBond 40.5" x 90'

## TriMount Dry Mounting Tissue

TriMount is a premium quality multipurpose breathable dry mounting tissue that is permanent and non-reversible. Coated on both sides of the tissue with a pH neutral adhesive which bonds at 185-212 degrees in 1-2 minutes. TriMount is recommended for mounting resin coated (RC) photographs, posters, and prints.

Item #	Description
1422	TriMount 25.5" x 150'
1424	TriMount 36.5" x 150'
1426	TriMount 41" x 150'



## Omega Permanent Bond Tissue

Comparable to ColorMount Dry Mounting Tissue, Omega presents a quality dual-sided porous, breathable heat-sensitive adhesive tissue. Adhesive permanently bonds at a low 180-degrees. Ideal for standard papers, RC photographs, watercolor papers, silk, polyester, fabric, foamboard and gatorboard, ink jet papers, and much more.

Item #	Size
OT401	24.5" x 150'
OT403	40.5" x 150'
OT406	40.5" x 300'

## Omega Acid-Free Clear Tissue

Compares to FloBond, pH neutral bonds at 175-200°.



Item #	Size
OT418	24.5" x 90'
OT419	40.5" x 90'





## Silicone Release Paper

This silicone-treated paper can be used as a cover sheet in most dry mounting and laminating jobs. Seal Release Paper protects both the press and the materials from any adhesive overhang. Reusable.

Item #	Description
3056	26" x 15' Roll 
3058	34" x 90' Roll 

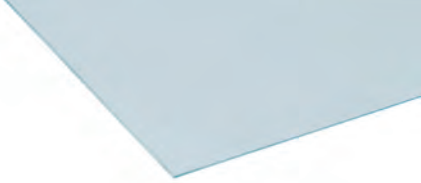

## Silicone Coated Release Board

Seal release board is smooth thin cardboard coated with silicone on both sides. They are extremely durable, reusable and easy to handle. Release Boards protect your artwork and keep your press platen clean. They are ideal for holding curled materials flat, while preventing "platen lines" on oversized work mounted in any heat press. Precut to size.

Item #	Description
3079	40" x 60" Release Board 

## OMEGA<sup>+</sup>

### Omega Double-Sided Release Paper

Omega's double-sided release paper is a smooth, white paper coated with silicone on each side. Recommended for use as a protective overlay/cover sheet for projects which also protects the dry mount press platen from any overhang of adhesives. Due to its silicone coating, one sheet can be re-used many times. 

Item #	Description
OT415	34" x 90' Roll
OT416	42" x 90' Roll

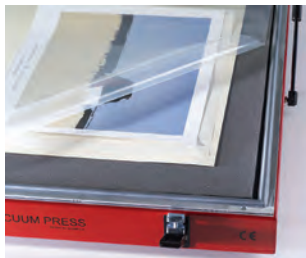

### Omega Silicone Release Film

Omega's release film is a high quality non-stick crystal clear polyester film that allows see-through inspection of the mounting process. Silicone coated on both sides, this ultra-durable film is stronger and more flexible than release paper and is an ideal choice for vacuum heat presses.

Item #	Description
1486	41" x 82 ft. Roll 



## DRYTAC<sup>®</sup>

### ArtShield UV Laminating Films

Optically clear, vinyl based heat activated lamination films are an economical mounting solution that can be applied quickly and easily with any heat press or hot roller laminator. The adhesive coating is initially low-tack, allowing for removal or repositioning prior to final mounting. pH neutral adhesive has UV absorbing properties making them ideal for prints, posters, photos, etc.

#### ArtShield Matt:

ArtShield Matt™ UV (3.0mil) is a HeatSet™ PVC (vinyl) laminating film that offers a soft non-glare matte finish without sacrificing any color detail. 41" x 50' roll

Item #	Description
1464	41" x 50 ft. Roll 

#### ArtShield Mattex:

ArtShield Mattex™ UV (3.0mil) laminating film is ideal for laminating canvas mounted photographs. When provided with adequate dwell time, temperature and pressure, Mattex film will take on the texture of the canvas for a beautiful textured finish.

Item #	Description
1474	41" x 50 ft. Roll 

#### ArtShield Satinex:

ArtShield Satinex™ UV enhances posters, digital prints and photographs. Popular applications include laminating fabrics, canvas, and raised surfaces such as leaves and dried flowers. Satinex has a semi-gloss finish and provides excellent UV protection.

Item #	Description
1452	41" x 50' Roll 

#### ArtShield Linentex:

ArtShield Linentex™ UV (5.0 mil) is a PVC (vinyl), HeatSet™ laminating film with an embossed linen-like finish. The textured non-glare finish of ArtShield Linentex UV is ideal for framed portraits, diplomas and certificates.

Item #	Description
1373	25.5" x 50 ft. Roll 



## D&K Expression<sup>®</sup> (Formerly Bienfang)

### D&K Expression Finish Guard UV Laminating Films

Finish Guard UV Films protect the surface of prints, posters, etc, from moisture, dust, and fingerprints. The protective film adheres directly to the front surface of the item being laminated. The process is non-reversible. The film is a paper carrier with grid lines, and is coated with a very low tack adhesive to aid initial positioning. Stronger adhesive is heat activated during the lamination process. This film is pre-pierced to prevent air bubbles and for ease of use. These overlaminating films feature ultra violet protection coatings and a low bonding point of 200 degrees - for one to three minutes in a mechanical press - longer for vacuum and roller presses. These overlamination films are ideal for use with ink jet and other heat sensitive media. They are optically clear, durable, and light weight.

#### Finish Guard Satin Matte:

Satin Matte provides a soft, non-reflective surface for an even low-gloss satin finish. 41" x 50' roll

Item #	Description
BF1306	41" x 50' Roll 

#### Finish Guard Canvas:

Finish Guard Canvas gives posters, prints, and photographs the rich texture of artist's canvas with a soft sheen. 41" x 50' roll

Item #	Description
BFH1671	41" x 50' Roll 



### D&K Foam Overlay for Laminating Materials

Specifically designed for the lamination process. Reusable, high density, heat resistant gray foam rubber sheeting, used to protect mounted surface during mounting, allows air and moisture to escape, and provides a uniform padded surface to yield consistent blemish-free results.

Item #	Size
BF1309	42" x 8.5 ft. 







## Bienfang Perforator

Hand held 5 wheel piercing tool used to create tiny perforations for the release of hot air. Prevents the formation of air bubbles with non-perforated dry mount tissues, especially when mounting non-porous papers or RC Photos. 

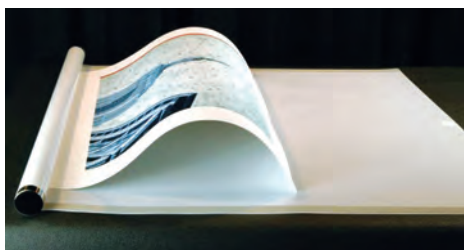
Item #	Description
1256	Bienfang Perforator 



## D&K De-Roller

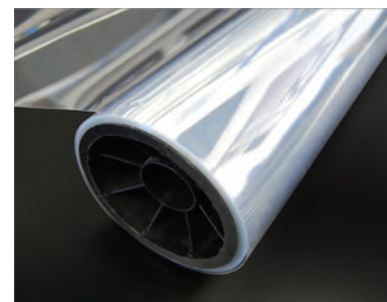

This first-of-its-kind tool takes the curl out of rolled prints, posters, and fine art. This accessory provides an ingenious solution to an age-old problem and takes only minutes to do.  

- Item **3083** : 50" x 38", 1½" diameter to uncurl smaller size prints



## Archival Encapsulation Film



Preserve intact documents, photos, newspapers, artwork or collective treasures by encapsulating them between two sheets of film. The ultra-clear film is UV resistant and acid free. Apply the archival grade double sided tape (1/8" away from article) to one sheet of film. Remove liner from adhesive and place second sheet of film on top. Burnish edges to bond, and trim excess film and tape. Your treasure is secure and protected. This will leave your article in its original state and allow for framing or archival storage. 

Item #	Description
1729	40" x 25 ft. Roll 
4040	42" x 100 ft. Roll 



## Scotch Positionable Mounting Adhesive

Dry mount projects without heat, sprays, or odors. No machine required. Allows repositioning before permanent bonding. Formulated for sensitive papers and colors that can't hold up to heat, as well as thin papers and digital printouts. Convenient application, every time, anywhere. For professional artists and framers for mounting, paste-up work, laminating, burnishing, and matting. 

Item #	Description
1085A	11" x 50 ft. Roll 
1085B	16" x 50 ft. Roll 
1085C	24" x 50 ft. Roll 



## Black Baron Tacking Iron

The Black Baron tacking iron features an adjustable temperature dial, letting you control temperatures that range from 150°F up to 475°F. Thermostatically controlled; just dial thermostat to desired setting to maintain even and constant heat. Non-stick coating ensures long-life use and allows iron to glide over your protective cover sheet without scratching. Metal wire stand included. 5.5' AC power cord. 

Item #	Description
TACKIRON	Black Baron Tacking Iron 



## 21st Century Adjustable Tacking Iron

Advanced built-in solid-state thermostat maintains heat within 3° of dial setting. Temperature range of 150 to 410°F. Unique iron with dial on the handle for controlling temperature without touching the heated shoe. Indicator light will blink when the iron reaches the desired dialed-in temperature. 100% blackstone shoe coating resists scratches & adhesive buildup. Metal wire stand and cotton iron sock included. 5' AC power cord. 

Item #	Description
ADJIRON	21st Century Tacking Iron 

## D&K Tacking Iron

Get professional results with the D&K tacking iron, designed for use by photographers, picture framers and conservators. Teflon coated surface prevents sticking while the pointed shoe design allows tacking in small corners. The new preset self-regulating control assures safe operation and long life. 

Item #	Description
4023A	D&K Tacking Iron 

*Regarding clogged nozzles on spray adhesive cans such as 3M Super 77:* We occasionally get calls from customers that their cans of spray adhesive worked only for a short time; where there is adhesive left in the can but does not come out when the nozzle is depressed. This is a common issue caused by not cleaning the nozzle after each use. **3M directions:** After each use, invert the can and depress the nozzle until no adhesive comes out. This will clear the nozzle of the adhesive that will cause any clogging. 3M also recommends removing then cleaning the clogged nozzle with adhesive remover or acetone, or take a nozzle from another can to try on the clogged can.



### 3M Repositionable 75 Spray Adhesive

3M Repositionable 75 Spray Adhesive is a repositionable adhesive that provides tape-like bonds. Excellent for production line work where parts are held in place temporarily prior to final assembly. Bonds many types of cloth, paper, cardboard, acetate, foil, plastic sheeting, etc. and adheres in seconds after sprayed. 

Item #	Description
3MREP75	10.25 oz. can



### 3M Hi-Strength Spray Adhesive 90

A very strong, fast-drying, contact-like adhesive, 3M™ Hi-Strength 90 Spray Adhesive is ideal for bonding heavy duty materials such as foam board, acrylic, heavy fabrics, gator-board, metal and more. 

Item #	Description
3MS90	17.6 oz. can



### Sprayway Fast Tack 87 Adhesive Spray

Fast Tack 87 General Purpose Mist Adhesive is a high performance mist adhesive used for both temporary and permanent bonds. It is a versatile general purpose adhesive ideal for use in mounting fabrics to many substrates, bonding decorative papers, etc. Non-staining formula makes it suitable for use on a great variety of projects. 

• Comparable to 3M 77

Item #	Description
SP87	13 oz. can



### 3M Vac-U-Mount Spray Adhesive

Formulated for use with a vacuum press for mounting works on paper and fabrics. Bonds permanently without discoloration, cracking, or bleed through. Requires no heat. Extended open time (up to 10 minutes) allows you to spray and bond even the largest materials. 

Item #	Description
3MVUMS	15.25 oz. can



### 3M Super 77 **LOW VOC!**

3M™ Super 77™ Multipurpose Adhesive is an extremely versatile, fast-drying adhesive that bonds a wide range of lightweight materials. Its fast, aggressive tack and low soak-in make it ideal for projects all around your home or business. It forms strong bonds with everything from paper, cardboard, fabric and cushion foam to plastic, metal, wood and more. 

Item #	Description
3MS77	18 oz. can



### Sprayway Fast Tack 89 Specialty Adhesive

A pressure sensitive mist adhesive intended for use for lightweight temporary bonds and repositionable applications. This adhesive has no permanent bonding capability. It has fast aggressive tack and good shear strength. When allowed to properly tack, the adhesive will not stain or transfer to other surfaces. 

• Comparable to Spraymount

Item #	Description
SP89	13 oz. can



### Elmers Repositionable Mounting Spray

Repositionable mounting spray will stick and re-stick over and over. It provides a light tack in seconds and dries fast and clear. Specially formulated for repositionability or temporary bonding on a single surface. Ideal for use with project where short term adhesion is needed. Use on paper, foil, cork, metal, wood, films, felt, foams, fabrics, leather, glass, plastics and more. 

Item #	Description
BFE454	10 oz. can



### Elmers Extra Strength Spray Adhesive

Acid-free and photo safe. Permanent bond when dry. Fast tack - dries clear. Extra Strength formulation for mounting items to a variety of surfaces, including plastics, photos, fabrics, paper, foil, cork, metal, wood, films, felt, foams, canvas, leather, glass, cardboard, and foam rubber. Sprays wide to cover large areas. Resists "bleed-through". 

Item #	Description
BFE456	10 oz. can



### BOSS Silicone Sealant Spray Adhesive

Unique spray application is designed to ensure adhesive stays workable. Superior adhesion to wood, metal, concrete, or glass. Dries to a flexible, rubbery solid. Will not chip, crack, shrink, dry out, or discolor. Sets in 2 hours, fully cures in 24 hours. 

Item #	Description
1045	8 oz. can



Items with this symbol "Ride Along" with your length or chop moulding order at no extra delivery charge.



Items with this symbol are Special Order from the U.S.





**Miter Magic™ Polyvinyl Glue**

Special formulation makes Miter Magic the strongest glue for joining wood frames available in the industry. Glue dries fast and clear and is water soluble for easy cleanup and handling.

Item #	Description
GL100	1 Pint Bottle
GL200	1 Gallon Bottle



Same formula as Miter Magic

**Black Magic™ Black Polyvinyl Glue**

Black Magic black polyvinyl glue is a great solution for joining black/dark mouldings. Dries fast and is water soluble for easy cleanup and handling.

Item #	Description
GL300	1 Pint Bottle
GL350	1 Gallon Bottle



Framer's Glue  
Pint • GL500

Framer's Glue  
Gallon • GL600

Mounting Glue  
Gallon • GL400

**Framer's Glue™ Polyvinyl White Glue**

Framer's Glue is a general purpose economy polyvinyl glue with a thinner viscosity to allow its use in a wide array of projects and can be used in automatic glue applicators. Dries fast and clear and is water soluble for easy cleanup and handling.

Item #	Description
GL500	1 Pint Bottle
GL600	1 Gallon Bottle

**All Purpose Mounting Glue**

Premium quality, pH neutral, acid free, water soluble mounting adhesive for use in cold vacuum mounting presses or when mounting by hand. Can be applied easily by roller, spray gun, or brush.

Item #	Description
GL400	1 Gallon Bottle



**Corner Weld™ Polyvinyl Glue**

This strong bonding all-purpose glue is perfect for all wood frames in addition to many other jobs throughout the frame shop. Dries clear, cleans up with water, and has a long shelf life.

Item #	Description
9100	1 Pint Bottle
9101G	1 Gallon Bottle

**VacuGlue 300**



VacuGlue 300 is a natural vegetable starch based adhesive that is pH neutral (acid free), water soluble, odorless, and freeze-thaw stable. It may be applied with a brush, roller, or spray gun, and sets quickly with either a vacuum press, dry mount press, or a rubber brayer. The bond is unaffected by changes in temperature and humidity, and remains reversible at all times. Contains no solvents and cleans up easily with water.

Item #	Description
BF461	64 oz. Bottle



**MITER FUSION™**

Safer than MEK Formula!

**Miter Fusion™ Glue for Polystyrene Moulding**

This acrylate adhesive is environmentally safe, containing no V.O.C.s. Specially formulated for polystyrene and other plastic mouldings. Safer to use than traditional styrene glues. Extremely fast drying & quick setting.

Item #	Description
GL700	8 oz. Bottle
GL800	16 oz. Bottle

**Professional Fabric Adhesive**



Ideal for almost any fabric, fine, or heavy, this fabric adhesive is well suited for creating fabric mats and custom fabric liners with moulding. Can be applied evenly and easily by hand with roller (on flat surfaces) or brush (on mouldings). Water soluble when wet, making for easy handling and clean up and water resistant when dry for durability.

Item #	Description
1026B	1 Gallon Bottle



**UnStik® Adhesive Release**

Special adhesive releasing solvent used to remove artwork from various mounting adhesives. It can also be used to clean adhesive residue off artwork or press parts. *Can not ship Puralator due to hazmat regulations.*

Item #	Description
BF470	1 Quart Can



**Un-du® Adhesive Remover**

Safely removes all self-sticking and pressure sensitive stickers, tapes, labels and adhesives on contact.

Acid free and photo safe, leaves no residue or staining after evaporation.

Item #	Description
3017	4 oz. Bottle
3019	32 oz. Bottle



## Braided Picture Wire

High quality braided picture hanging wire is made of heavy duty pliable galvanized steel. 5 lb. spools

Available in 6 gauges:		<i>Approx. Ft. Per Spool</i>
<b>WPB201</b> • #2	12 lbs. max picture weight	1500 ft.
<b>WPB301</b> • #3	16 lbs. max picture weight	1025 ft.
<b>WPB401</b> • #4	20 lbs. max picture weight	910 ft.
<b>WPB501</b> • #5	24 lbs. max picture weight	740 ft.
<b>WPB601</b> • #6	28 lbs. max picture weight	650 ft.
<b>WPB801</b> • #8	36 lbs. max picture weight	500 ft.



## Easy-Fit® Nylon Coated Stainless Steel Wire

Easy-Fit is a new ultra-flexible nylon coated stainless steel picture framing wire that framers love. Easy-Fit is smooth and ouchless (easy on the fingers!), and is easy to wrap or knot. Special coating makes Easy-Fit kink-free, leaves walls unmarked, and easily adjusts on wall hangers. 

Available in 6 gauges:		<i>Approx. Ft. Per Spool</i>
<b>WPC201</b> • #2	15 lbs. max picture weight	1500 ft.
<b>WPC301</b> • #3	20 lbs. max picture weight	1125 ft.
<b>WPC401</b> • #4	25 lbs. max picture weight	850 ft.
<b>WPC501</b> • #5	43 lbs. max picture weight	500 ft.
<b>WPC601</b> • #6	60 lbs. max picture weight	275 ft.
<b>WPC801</b> • #8	100 lbs. max picture weight	125 ft.



## Super SoftStrand® Plastic Coated Stainless Steel Wire

Super Soft Strand, is plastic-coated stranded stainless steel wire for picture framing. The clear kink resistant coating has a very soft feel that is smooth on your fingers and easy to twist. You can wrap it tight and secure knots without puncturing your fingers or wrestling the stiff sharp ends like uncoated braided or other plastic coated wires. Available in individual spools, this is the preferred picture framing wire throughout the industry and it's made in USA.

Available in 6 gauges:		<i>Approx. Ft. Per Spool</i>
<b>WPS201</b> • #2	15 lbs. max picture weight	1500 ft.
<b>WPS301</b> • #3	20 lbs. max picture weight	1125 ft.
<b>WPS401</b> • #4	25 lbs. max picture weight	850 ft.
<b>WPS501</b> • #5	43 lbs. max picture weight	500 ft.
<b>WPS601</b> • #6	60 lbs. max picture weight	275 ft.
<b>WPS801</b> • #8	100 lbs. max picture weight	125 ft.



## Picture Wire Caddy

Tabletop wire caddy holds 5lb. spools of braided picture wire for easy dispensing and control of spools on your work table. Holds all wire gauges and has center slot to feed wire without it riding off of the spool. Complete with handle for portability.

<i>Item #</i>	<i>Description</i>
<b>WC1000</b>	Wire Caddy

• Pictured with wire (not included)



## SoftStrand® Stainless Steel Wire

The original "finger-friendly" picture wire, this high-strength, corrosion resistant stainless steel is soft, flexible, and fray resistant. Stainless steel finish will not mar walls or hands and will retain its strength and will not corrode or discolor.

Available in 7 gauges:		<i>Approx. Ft. Per Spool</i>
<b>870-1</b> • #1	12 lbs. max picture weight	1650 ft.
<b>870-2</b> • #2	20 lbs. max picture weight	1125 ft.
<b>870-3</b> • #3	30 lbs. max picture weight	825 ft.
<b>870-4</b> • #4	35 lbs. max picture weight	625 ft.
<b>870-5</b> • #5	40 lbs. max picture weight	550 ft.
<b>870-6</b> • #6	50 lbs. max picture weight	465 ft.
<b>870-8</b> • #8	60 lbs. max picture weight	375 ft.





## Using the Surflon® System

Surflon® wire is smooth, nylon-coated stainless steel wire that is secured with crimping sleeves and a crimping plier. The Surflon System saves you time by eliminating the need to tie or wrap, and it creates a custom, professional appearance.

To achieve the professional look and dependable strength of the Surflon System, just follow these few simple steps:



**Note:** Factors such as hardware and wall construction may affect the maximum picture weight to be used. Therefore, to achieve the safest and strongest hold, do not exceed the recommended maximum picture weight for each size of Surflon wire.

## Surflon Wire System

The Surflon® Starter Kit is a great way to try the Surflon system! Each kit contains detailed instructions, a 300 ft. (92 m) spool of Surflon wire, 200 crimping sleeves, and a pair of Deluxe Crimping & Cutting Pliers. This is enough material to wire approximately one-hundred 24" x 36" (61 cm x 91 cm) frames. The kits are economically priced so you can try the system without having to purchase larger spools and packages of sleeves. Give it a try...once you use Surflon, you'll never wrap wire again!

### #2 Wire System Kit

• 30 lb. maximum hanging weight

Item #	Color
6794	Bright
6795	Black

### #3 Wire System Kit

• 40 lb. maximum hanging weight

Item #	Color
6796	Bright
6797	Black

### #4 Wire System Kit

• 60 lb. maximum hanging weight

Item #	Color
6798	Bright
6799	Black



## Surflon Coated Stainless Steel Wire

This nylon coated stainless steel wire is designed to be used with Surflon crimping sleeves as part of the Surflon wiring system. Available in Bright (silver), Black, and Bronze. 1000 feet per spool.

Item #	Color	#	Wt.
6801	Bright	2	30
6802	Bright	3	40
6803	Bright	4	60
6804	Bright	7	105
7801	Black	2	30
7802	Black	3	40
7803	Black	4	60
7804	Black	7	105
9211W	Bronze	6	45
9212W	Bronze	7	68



## Surflon Crimping Sleeves

Surflon sleeves are made of copper and are designed to be used with Surflon wire and crimping tools. Match Surflon sleeve sizes to corresponding Surflon wire sizes for tight, secure connections that are virtually impossible to come apart.

• *Designed to be used with Surflon wire only; not guaranteed to work with other wires.*

Item #	Color	Size
6811	Bright	#2
6812	Bright	#4
6813	Bright	#7
7811	Black	#2
7812	Black	#4
7813	Black	#7
9213W	Bronze	#6
9214W	Bronze	#7



## Surflon Crimping Pliers

This tool has three crimping dies designed for crimping all sizes of Surflon sleeves. Added cutting tip added to snip wire.

Item #	Description
9210W	Surflon Crimper



## C+H No. 1200™ Mat Cutter Blades

Fits C+H & Fletcher Mat Cutters. High quality steel blades for general mat cutting use. Available in double edge for regular cutting and single edge fine cutting. 100 Blades per box. • .012 gauge

Item #	Description
9229	#1200SE: Single Edged
9230	#1200: Double Edged



## C+H No. 1500™ Mat Cutter Blades

Fits C+H & Fletcher Mat Cutters. High quality steel blades for rag mats & heavy duty cutting. Available in double edge for regular cutting and single edge for fine cutting. 100 Blades per box. • .015 gauge

Item #	Description
9228	#1500SE: Single Edged
9231	#1500: Double Edged



## Logan™ Mat Cutter Blades

Pack of 100 Logan Style 270 Mat Cutter Blades for use with Logan Mat Cutter numbers 301, 301S, 401, 700S, 700SGM, 701, 760SGM, 1000, 2000, 3000, and 4000. 1 1/2" x .012 gauge blades.

Item #	Description
BL1004	100 1.5" x .012 blades



## Omega Mat Cutter Blades

Fits C+H & Fletcher Mat Cutters. High quality steel blades: .012 gauge for regular mat cutting, and .015 gauge blades for rag mats & heavy duty mat cutting. Both gauges are available in double edge for general cutting and single edge for fine cutting of rag mat, 8ply and specialty mats. 100 Blades per box. 

Item #	Description
BL1000	.012 Single Edged Blades
BL1001	.012 Double Edged Blades
BL1002	.015 Single Edged Blades
BL1003	.015 Double Edged Blades



## Razor Blades

High quality stainless steel single edged razor blades for a great number of general use cutting needs around the frame shop. Available with notched edges or without to fit into certain tools and blade holders. 100 razors per box. 

Item #	Description
BL1007	#9 Blade, Notched • 100 blades
BL1008	#12 Blade, Notched • 100 blades
BL1009	#12 Blade, No Notch • 100 blades



• Use with straight edges see page 70.

## Dexter Mat Cutter

Cuts a straight or bevel edge with absolute accuracy. Push along T-square or straight edge to guide your cut. Great frameshop staple; use for oversize cuts that exceed your machine. Knob adjusts blade to any angle or depth. Chrome plated. Complete with five No. 3 blades.

Item # **DEXMATCT**

## Dexter Style Mat Cutter Blades

Available in packs of 5 or 100, these stainless steel blades are made to fit the Dexter line of hand held manual mat cutting tools and the Professional Trimming Tool (H135) used for cutting backing papers. 



Item #	Description
BL1010	5 ct. 1.5" x .012 blades
BL1011	100 ct. 1.5" x .012 blades



• Expertly crafted in England from Sheffield Steel!



## Keencut™ Medium Duty Blades

For Keencut machines, these medium duty blades made in England from world-renowned Sheffield Steel, provide a longer life and superior edge for performance cutting up to 3/8" thick. Fits Keencut cutters Excalibur 1000x & 5000, Ultimat Futura, Flexo Futura, Ultimat Gold, SteelTrak, Sabre series, Javelin series, Evolution series, Max, Simplex, and Artist series cutters. 100 blades/pack

Item #	Description
MDBLADES	100 Blade Pack  

## Keencut™ Heavy Duty Blades



For Keencut machines, these heavy duty blades are made in England from world-renowned Sheffield Steel, provide a longer life and superior edge for performance cutting up to 1/2" thick materials on vertical cutters. Fits Keencut cutters Excalibur 1000x & 5000, Ultimat Futura, Flexo Futura, Ultimat Gold, SteelTrak, Sabre series, Javelin series, Evolution series, Max, Simplex, and Artist series cutters. 100 blades/pack

Item #	Description
HDBLADES	100 Blade Pack  



## Hassle-Free Trimming Tool

Used for trimming paper dustcovers and backing tape on the reverse of frames. The blade is set 3mm in from the edge to allow a neat, clean finish. Ergonomic handle makes cutting a breeze and can be used right or left handed.

Item #	Description
HFTRIMTL	Hassle-Free Trimmer  



## Professional Trimming Tool

Exposed blade fits into a molded tract that allows for maximum finger protection & superior eyesight lines for the cleanest, most convenient trimming of backing paper. Uses Dexter style blades for blade replacement. Tool comes with 5 blades. 

Item #	Description
H135	Trim Tool w/5 blades



Items with this symbol "Ride Along" with your length or chop moulding order at no extra delivery charge.





## Retractable Utility Knife

Solid cast metal retractable utility knife made to last and made in the USA. Uses utility blades **BL1005** (General Duty, .017 thick) and **BL1006** (Heavy Duty, .025 thick). Handle has receptacle for extra blade storage (comes with 3 blades).

Item #      Description

**BL1012** Utility Knife w/3 blades



## Snap & Retract Utility Knife

Lightweight & handy utility knife that uses a single strip, 8-point snap-off blade. Conveniently renew each blade point simply by snapping off used section with pliers to expose new edge. Retract blade for safety. Comes with 1 8-point blade.

Item #      Description

**BL1013** Snap Knife w/1 strip

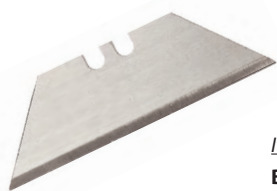

## Utility Blades

General Duty (.017 thick) and Heavy Duty (.025 thick) utility blades for use in retractable knife and other cutting tools. 100 blades per pack

Item #      Description

**BL1005** 100 General Duty Blades

**BL1006** 100 Heavy Duty Blades



## Snap Blades

Quality carbon steel 8-point blades for use in Snap & Retract Utility Knife (BL1013). 10 8-point blades per pack

Item #      Description

**BL1014** 10 8-point Snap Blades

**7010MR** 100 8-point Snap Blades 

## X-ACTO® Gripster

X-Acto's Gripster Knife features a soft rubberized barrel for a firmer, more comfortable grip and better control. Rear blade release makes blade changing safer, easier, and faster. One blade is included.

Item #      Description

**BFX3627** XACTO Gripster Knife

**BLX211** XACTO #11 Blades (5 pack)

Xacto  
#11 Blades  
BFX211



## Hobby Knife #1

Hobby Knife #1 has a 4 3/4" long aluminum handle with threaded blade vise, and comes with a standard #11 blade, (BL1015 & BL1016) and safety cap.

Item #      Description

**BL1017** Hobby Knife #1



## Hobby Knife Blades

#11 Blades for Hobby Knife #1 & XACTO Gripster (BFX3627). Available in packs of 5 & 100.

Item #      Description

**BL1015** 5 #11 Blades

**BL1016** 100 #11 Blades



## XACTO® #8 Board Cutter Blades

5 dual-sided replacement blades for the XACTO Board Cutter (BFX7747).

Item #      Description

**BFX208** 5 # 8 Blades



Items with this symbol "Ride Along" with your length or chop moulding order at no extra delivery charge.



## Omega Corner Nails

Manufactured for reliability and ease of use, Omega Corner Nails are crafted with a single sharpened edge on high quality steel to ensure smooth fluid penetration into wood or plastic mouldings. Designed for hard wood, soft wood, medium-density fiberboard (MDF), and polystyrene mouldings, and for use with Pistorius, Putnam/AMP, and Cassese pneumatic underpinners.

### Corner Nails for Pistorius Underpinners

Item #	Size	Wood Type	QTY/Box
VN2000	1/4"-7mm	Soft Wood	6000
VN2001	1/4"-7mm	Hard Wood	6000
VN2002	3/8"-10mm	Soft Wood	6000
VN2003	3/8"-10mm	Hard Wood	6000
VN2004	1/2"-12mm	Soft Wood	6000
VN2005	1/2"-12mm	Hard Wood	6000
VN2006	5/8"-15mm	Soft Wood	6000
VN2007	5/8"-15mm	Hard Wood	6000

### Corner Nails for Putnam/AMP Underpinners

Item #	Size	Wood Type	QTY/Box
VN3000	1/4"-7mm	Soft Wood	6000
VN3001	3/8"-10mm	Soft Wood	6000
VN3002	1/2"-12mm	Soft Wood	6000
VN3003	5/8"-15mm	Soft Wood	6000
VN3004	1/4"-7mm	Hard Wood	6000
VN3005	3/8"-10mm	Hard Wood	6000
VN3006	1/2"-12mm	Hard Wood	6000
VN3007	5/8"-15mm	Hard Wood	6000

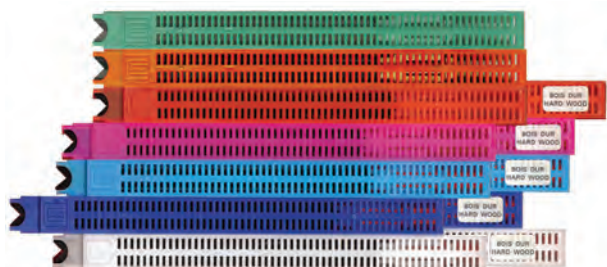

### Corner Nails for Cassese Underpinners

Item #	Size	Wood Type	QTY/Box
VN4000	1/4"-7mm	Soft Wood	1650
VN4001	1/4"-7mm	Hard Wood	1650
VN4002	3/8"-10mm	Soft Wood	1650
VN4003	3/8"-10mm	Hard Wood	1650
VN4004	1/2"-12mm	Soft Wood	1650
VN4005	1/2"-12mm	Hard Wood	1650
VN4006	5/8"-15mm	Soft Wood	1650
VN4007	5/8"-15mm	Hard Wood	1650



Inmes V-pins fit INMES, Charnwood, Morso, Delta, Euro, & Fletcher models 5000 & 5100

### Inmes Universal V-Pins

Item #	Size	Wood Type	QTY/Box
3749S	3/16"-5mm	Soft Wood	6000
3750H	1/4" - 7mm	Hard Wood	4000
3750S	1/4" - 7mm	Soft Wood	4000
3751H	3/8"-10mm	Hard Wood	3000
3751S	3/8"-10mm	Soft Wood	3000
3752H	1/2"-12mm	Hard Wood	2000
3752S	1/2"-12mm	Soft Wood	2000
3753H	5/8"-15mm	Hard Wood	2000
3753S	5/8"-15mm	Soft Wood	2000

 Items with this symbol "Ride Along" with your length or chop moulding order at no extra delivery charge.

 Items with this symbol are Special Order from the U.S.



## Thumbnail Frame Joining Inserts

Thumbnail inserts are the strongest, most durable inserts for a variety of moulding sizes. All three insert sizes are tapered to draw the face of the moulding together when joined with glue. 

Item #	Description
5051	3/8" - Qty. 500 inserts
5052	5/8" - Qty. 500 inserts
5053	15/16" - Qty. 250 inserts



## Router Bits for C+H Thumbnailer

Steel and carbide replacement bits for the C+H Thumbnailer Master router. 

Item #	Description
5054	Steel Replacement Bit
5054C	Carbide Replacement Bit

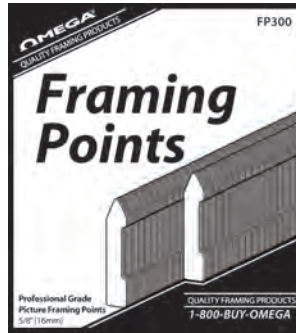

## Omega Framing Points

Omega Framing Points are designed to fit the Fletcher FrameMaster manual hard point driver. Box contains 3,000 5/8" (16mm) points per box. (100 points per stack).

Item #	Description
FP300	3000 Hard Points/Box



## Omega Flexible Framing Points

Omega Framing Points are designed to fit the Fletcher FlexMaster as well as manual flex point driver #FPDRIVER. Box contains 3,000 5/8" (16mm) points per box. (250 points per stack).

Item #	Description
FP500	5000 Flex Points/Box



## Omega Framing Points for Pneumatic Point Drivers

Long sleeve Omega Framing Points are designed to fit FrameMaster & compatible pneumatic hard point drivers. Box contains 12,000 5/8" long points per box.

Item #	Description
FP1200	12000 Hard Points/Box



## OMER Hardpoints

OMER Framing Points are designed to fit OMER pneumatic hard point driver (Item# 9285). Box contains 10,000 15mm points each.

Item #	Description
9286	10000 OMER Hard Points/Box 



## Flexible Framing Points for OMER Pneumatic Point Drivers

Flexible Framing Points are designed to fit OMER type pneumatic flexible point drivers. Box contains 5,000 5/8" (15mm) long points per box (Item FP77), or in 15,000 qty. box (Item 9287). 

Item #	Description
FP77	Inmes Flexible Points 5000/Box
9287	OMER Flexible Points 15000/Box 





## Framer's Hard Point Driver

This well engineered manual rigid-point driver features an all metal die-cast body with a comfort grip trigger handle that's built to last. Loads quickly and easily in front channel and firing pressure can be adjusted for different wood densities. Uses Inmes 16mm rigid framing points (Item FP85). 

Item #	Description
HPDRIVER	Hard Point Driver
Item #	Compatible Points
FP85	3000 Hard Points/Box 



## Framer's Flexible Point Driver



Built strong with the same all metal die-cast body as our Hard-Point Driver (above), this point driver fires 15mm standard flexible framing points. Easily load points in front channel and adjust firing pressure with back knob for different woods to control driving depth of flexpoint. Uses Fletcher-type flexible framing points (Item# FP500). 

Item #	Description
FPDRIVER	Flexible Point Driver
Item #	Compatible Points
FP500	5000 Flex Points/Box
FP77	5000 Flex Points/Box



## Framer's Pneumatic Point Drivers



These pneumatic point drivers feature a lightweight die-cast aluminium body, at a total weight of under 2 lbs. with a rubberized ergonomic comfort grip and safety catch on the operating trigger. Easy-to-operate in left-to-right or right-to-left single motion with no "pullback" required. Operates at 4.5bar/90psi. 

Item #	Description
PNRIGDR	Pneumatic Hard Point Driver (Red)
PNFLXDR	Pneumatic Flex Point Driver (Yellow)
Item #	Compatible Hard Points (Red)
FP1200	12000 Hard Points/Box
9286	10000 OMER Hard Points/Box 
Item #	Compatible Flexible Points (Yellow)
FP77	Inmes Flexible Points 5000/Box
9287	OMER Flexible Points 15000/Box 



## OMER Pneumatic Flexible Point Driver

OMER air flexpoint drivers fire 15mm flexible and rigid framing points. Lightweight and strongly constructed for reliability and years of use, OMER drivers are designed for volume production. Air drives with little noise, no recoil, and fast air recycle. Uses flexible points Item# FP77 and #9287. 

Item #	Description
9285	OMER Pneumatic Flexible Point Driver 
Item #	Compatible Points
FP77	Flexible Points 5000/Box
9287	OMER Flexible Points 15000/Box 



## Senco Pneumatic Brad Nailer



The Senco SLP20XP drives a wide range of both slight-headed and medium headed brads to give you two tools in one. Weighs only 2.3 lbs. - the lightest weight available in a brad nailer - for easy maneuvering and handling in small places. Features easy side loading that allows you to choose brad length without adjusting tool, plus an E-Z Clear jam feature allowing easy removal of a jammed fastener. Superior power (40% more than comparable tools) makes this 18 gauge brad nailer ideal for moulding and trim. Oil free design means easier maintenance and no lubrication to stain fine woods. Not recommended for fitting. Uses 1/4" male air nipple, not included. 

Item #	Description
100S	Senco Pneumatic Brad Nailer 



## Senco Pneumatic Long Nose Staplers

Compact and durable, the SFT10XP delivers best-in-class performance for a variety of fine wire stapling applications. Models drive staples ranging in length from 5/32-in to 5/8-in. Heavy-duty steel cap offers superior balance with minimal recoil and a one-handed magazine opening for increased productivity. Rear exhaust directs oil and dust away from the work surface. Short trigger stroke provides quick and precise operation. Long lip length makes getting into tight spots easier. Adjustable firing rate from single shot to 30 fasteners per second. 

Item #	Description
120	Senco (SFT10XP-C) C-Type Stapler Uses #114, #118, #119 C-type Staples 
110	Senco (SFW10XP-G) G-Type Stapler Uses #115, #116, #117 G-type Staples 



Items with this symbol "Ride Along" with your length or chop moulding order at no extra delivery charge.





Items with this symbol are Special Order from the U.S.



## Fasco Long-Nose C-Type Stapler

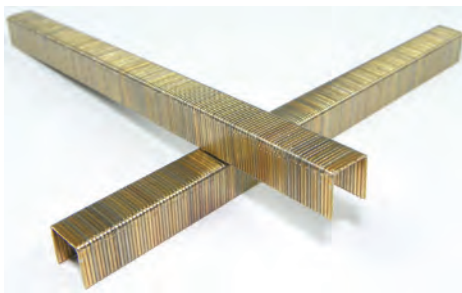

The Fasco F1B 7C-16 LN-50 long nose stapler delivers European reliability, power and refinement. Drives 3/8" crown width Senco C, BeA 71 and Empire 7 series staples. 2" nose length allows stapling in deep recesses and hard-to-reach places. Bottom load design provides ease and speed when reloading, changing sizes or clearing a jam. Staples range all the way from 1/4" to 5/8" leg lengths. Magazine opens with easy, one finger latch. Reversible bumper for added parts life. A comfortable, fast, and durable stapler great for production fitting and gallery wrap applications. Uses Item #5061 staples. Uses 1/4" male air nipple, not included.

Item #	Description
5060	Pneumatic C-Type Stapler  





## Fasco C-Type Staples

3/8" Crown 22-gauge wire staples for Fasco/Mastri/Senco pneumatic staplers. 10,000 per box.

Item #	Description
5061	3/8" C-Type Staples  





## Senco C-Type Staples

3/8" crown 22-gauge wire staples for Fasco/Mastri/Senco pneumatic staplers.  

Item #	Description
119	5/16" long C-Type Staples • 28,000/box
118	1/2" long C-Type Staples • 35,000/box
114	3/16" long C-Type Staples • 55,000/box



## Senco G-Type Staples

3/8" crown 20-gauge wire staples for Fasco/Mastri/Senco pneumatic staplers. 5,000 staples per box.  

Item #	Description
115	3/8" long G-Type Staples • 5,000/box
116	1/2" long G-Type Staples • 5,000/box
117	5/8" long G-Type Staples • 5,000/box



## Senco Brad Nails

• 5000 Galvanized nails per box  

Item #	Description
104	3/4" Senco AY11 Brads (small head)
105	5/8" Senco AY10 Brads (small head)
106	1" Senco AX13 Brads (medium head)
107	1 1/4" Senco AX15 Brads (medium head)
108	1" Senco AY13 Brads (small head)



## Framer's Vise

Holds miters in perfect alignment for non-slip fastening. Securely clamps moulding up to 4" wide at 90° for joining and nailing. Table mount base.

Item #	Description
FRVISE4	Framers' Miter Vise 



## One-Handed Frame Clamp

Ratcheting band Clamp ideal for gluing picture frames. Self-adjusting corners holds various angles, and includes 16-feet of strap.

Item # SCL16

## Master Clamp

Master Clamp joins frames under high pressure only using glue. Patented design clamp evenly distributes glue evenly along joined surfaces with 1000 lbs. of pressure per square inch and reduces drying time to approximately 20 minutes creating a bond that is stronger than any other tool on the market. The oversized front clamping fence is fixed at a perfect 45 degrees and its fine closing adjustment feature and spring-loaded back fence adjustment.

- Eliminates the need for wax fillers/putty
- Comes ready to use right out of the box
- Comes complete with 2 moulding levelers



## Master Clamp L

For large mouldings up to 3 1/2" wide.

Item # 5105 

## Master Clamp XL

For extra-large mouldings up to 6 1/2" wide.

Item # 5106 

## Master Clamp Shadow Boxer

For large shadow box depth mouldings.

Item # 5107 



See Page 59 for our complete line of Silent Air Compressors



**TAKIYA** exclusively from **OMEGA**



**• Safety Mini Hanger Set**

A: Hanger & 6' Cable w/ ring for CA hook & CB hook.  
B: Hanger & 6' Cable for One-Touch hook.

**• Safety N Hanger Set**

A: Hanger & 6' Cable w/ ring for CA hook & CB hook.  
B: Hanger & 6' Cable for One-Touch hook.

Item #	Set / Description	Gauge	Weight
TAK1008	Safety Mini Hanger A	1.2mm	35 lb.
TAK1009	Safety Mini Hanger B	1.2mm	35 lb.
TAK1010	Safety N Hanger A	1.5mm	65 lb.
TAK1011	Safety N Hanger A	2.5mm	150 lb.
TAK1012	Safety N Hanger B	1.5mm	65 lb.
TAK1013	Safety N Hanger B	2.5mm	150 lb.

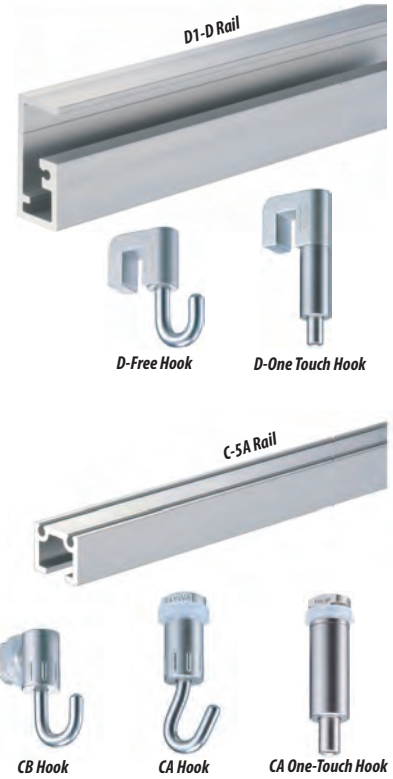

Item #	Description
TAK1000	C-5A Rail • 3 ft. section
TAK1001	CB Hook • 65 lb. capacity
TAK1002	CA Hook • 65 lb. capacity
TAK1003	1-Touch Hook • 65 lb. capacity

Item #	Description
TAK1004	D-1D Rail • 3 ft. section
TAK1005	D-Free Hook • 150 lb. capacity
TAK1006	Mini D-Free Hook • 35 lb. capacity
TAK1007	D 1-Touch Hook • 150lb. capacity

**MuSE by Takiya**

Framing and Hanging and hardware from Japan for situations where nothing but the best will do.

This patented line of superior quality stainless steel and aluminum hanging hardware has been used in museums and fine art galleries around the world.

Takiya's thoughtfully engineered products elegantly combine brilliant design with excellent functionality and safety for the hanging and support of valuable works of art and collectibles.

The picture rails can be built in or added to existing walls or ceilings. The hanger sets can be ordered with different components to create custom hanging solutions for a variety of display settings.

Many of these products are especially useful in earthquake prone areas where art must be secured for safety concerns.

Takiya - supporting great art.

• \$250 Price break is for \$250 purchase of Takiya products

All Takiya items are "Ride Along" eligible



Item #	Description
TAK1018	Joint Pin • aligns rail joins (2 required)
TAK1019	Corner Joint Pin • aligns corner joins (2 required)
TAK1020	C-5A End Cap • for surface mounted rail application



**Cable Wire**

1.2 and 1.5 mm gauge steel wire nylon coated with a clear finish and in a variety of colors designed to blend with many wall colors and exhibit schemes.  
• Sold in 6 foot lengths

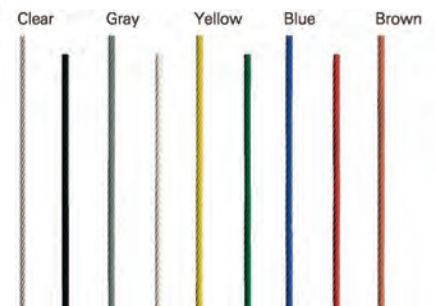

• Colored wire can be used to visually blend cables in with different wall colors.

Item #	Cable Gauge / Description
TAK1016	1.2mm clear coated + colors
TAK1017	1.5mm clear coated + colors

All Takiya items are Special Order from the U.S.



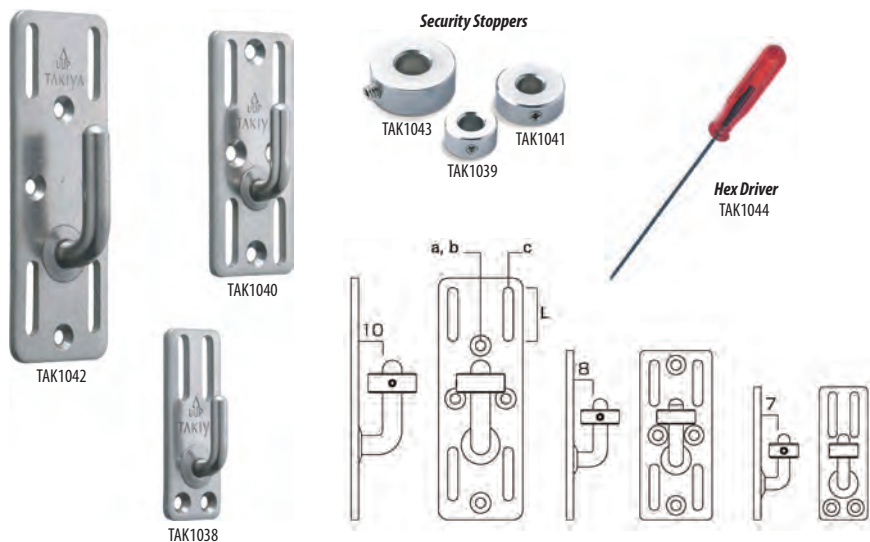

## Wall Hooks & Security Stoppers

These special wall hooks are ideal for hanging display pieces with the added ability of securing the work from damage or theft. Security stoppers can be fastened to the tip of the wall hook to secure the d-ring from being removed from the hanger. Stoppers can be added and removed by adjusting the inset hex screw with the available specially designed hex driver tool. *Stainless Steel • wall screws not included*

Item #	Description
TAK1038	110 lb. capacity wall hook
TAK1040	220 lb. capacity wall hook
TAK1042	330 lb. capacity wall hook

Item #	Description
TAK1039	Security Stopper (for 110 lb. hook)
TAK1041	Security Stopper (for 220 lb. hook)
TAK1043	Security Stopper (for 330 lb. hook)
TAK1044	Specialized 1.5mm Hex Driver

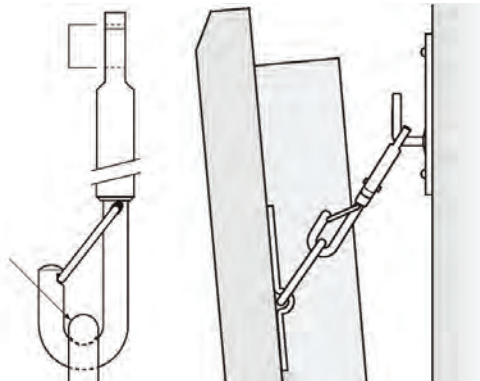
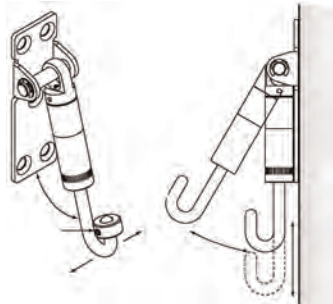

## Multiple Function Wall Hook

This hanger has multiple functions such as securing items to prevent damage due to accidents, earthquakes, or theft. Additionally, it is vertically and laterally adjustable for positioning and repositioning artwork while securely hanging. Works with 110 lb. security stopper (TAK1039). *Stainless Steel • 110 lb. capacity • screws not included*

Item #	Description
TAK1045	Multi-function wall hook • 110 lb. capacity

## Adjustable Offset Hanger

This hanger is used to hang uniquely shaped or unconventionally framed work that may not have a flat back or has an offset strap hanger. Height can be adjusted by turning the threaded dial on the hanger so that you can level, raise or lower the piece after being hung. Strong catch securely contains D-ring. *Brass/Stainless Steel • 110 lb. capacity*

Item #	Description
TAK1046	Adjustable offset hanger • 110 lb. capacity

## Wall Mounted Support Brackets

These wall brackets are the best solution for supporting large size and heavyweight displays. Attach to wall by screwing into wall stud to support weight at the bottom of the piece. *Stainless Steel, shot blast finish • 220 lb. & 330 lb. capacity brackets*

Item #	Description
TAK1047	Support Bracket • 220 lb. capacity
TAK1048	Support Bracket • 330 lb. capacity



Takiya - supporting great art.

TAKIYA

## Premium Strap Hangers

These premium strap hangers are made with superior materials to traditional strap hangers and are engineered and tested for stress and durability. The rings were designed and developed for use with the hanging hooks for the MuSE cable hanging system and all Takiya hooks, also compatible with traditional wall hooks. *Stainless steel • screws not included*

Item #	Description	Capacity
TAK1021	Strap Hanger	330 lb.
TAK1022	Strap Hanger	220 lb.
TAK1023	Strap Hanger	110 lb.
TAK1024	Strap Hanger	65 lb.
TAK1025	Strap Hanger	22 lb.

► Hardware that conveys first-class workmanship for all of your high-end framing projects



## Angled Hangers

These tastefully designed hangers have the rings set at the optimal angle to balance and reduce stress on the frame when hanging with wire. Hangers are sold in pairs (left and right side angled). *Stainless Steel*

Item #	Description	Capacity
TAK1026	Angled D-Rings (Pair)	100 lb.
TAK1027	Angled D-Rings (Pair)	65 lb.
TAK1028	Angled D-Rings (Pair)	35 lb.
TAK1029	Angled D-Rings (Pair)	22 lb.

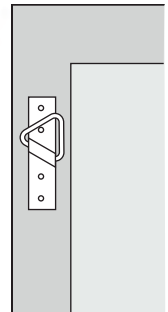

## Security Floret Wall Hooks

These beautiful stainless floret style wall hooks secure works by holding wire or D-ring on the hook by a metal clasp. Hooks can be fixed to wall by stainless steel pins or slim screws which minimize damage to the wall when removed. *Stainless Steel, Brass (pin head) • 15 lb. & 45 lb. capacity wall hooks*

Item #	Description	Capacity
TAK1049	1-Pin Security Floret	15 lbs.
TAK1050	3-Pin Security Floret	45 lbs. (pins included)



Heavy Duty Pins

Item #	Description
TAK1051	100 Pins / Box



Slim Screws

Item #	Size / Box Qty.
TAK1052	16mm / 540 ct.
TAK1053	19mm / 480 ct.
TAK1054	24mm / 370 ct.
TAK1055	27mm / 310 ct.
TAK1056	32mm / 250 ct.
TAK1057	36mm / 230 ct.

TAKIYA

Striking framing and hanging hardware will convey painstaking attention to detail that collectors and connoisseurs demand.

 All Takiya items are "Ride Along" eligible

 All Takiya items are Special Order from the U.S.

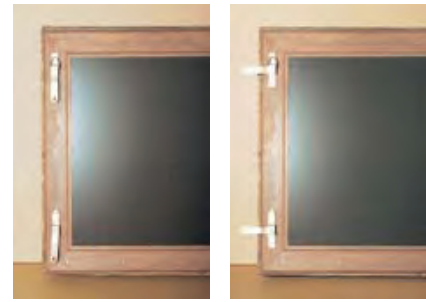
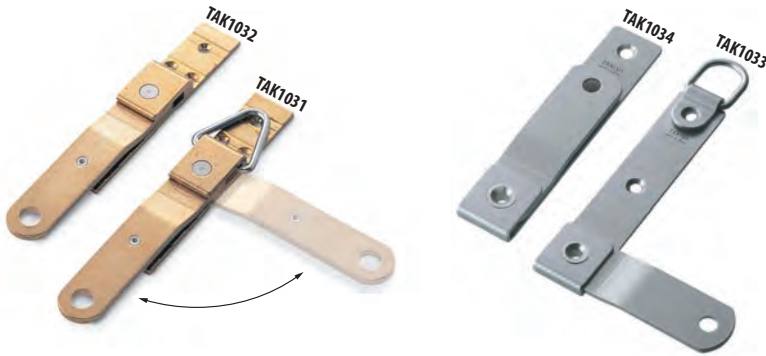

## Folding Shipping Braces

Folding Shipping Braces are used to attach artwork inside wooden crates for transportation. Braces swivel out to allow for reinforcing the arm to crating (with screws or bolts) and swivel in for storage or to hang piece on the wall (for models with stationary D-rings).  
Brass, Stainless Steel

- | Item #  | Description                               |
|---------|---|
| TAK1031 | Brass Shipping Brace with stationary ring |
| TAK1032 | Brass Shipping Brace                      |
| TAK1033 | Steel Shipping Brace with stationary ring |
| TAK1034 | Steel Shipping Brace                      |

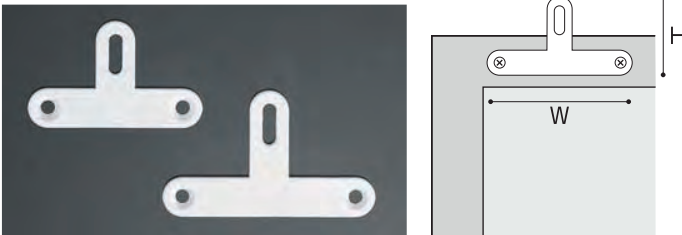

## T-Clip Flush Hangers

These T-shaped clips attach to the back of the frame and enable you to set it closely to the wall surface with wood screws. White coated metal blends into white walls when hanging. Oblong screw slots allow for adjusting and leveling hanging height.

- | Item #  | Description                    |
|---------|--------------------------------|
| TAK1036 | Small T-Clip • 1 3/4" x 1"     |
| TAK1037 | Large T-Clip • 2 1/8" x 1 1/4" |

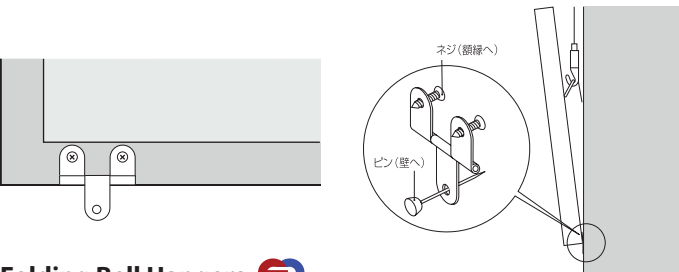

## Frame Wire Clips

Wire clips help prevent framed pieces from falling forward when hung by wire and also hold wired pieces closer to the wall for a uniform look. Clips can be attached to the back of the frame or to the wall. *Stainless steel clip • screws included*

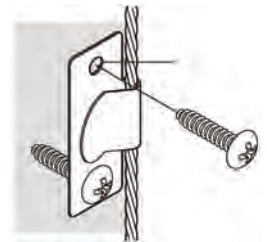

## Folding Bell Hangers

These hangers are designed to protect hanging artwork in the event of an earthquake or wire breakage by securing the frame to the wall. Hardware attaches to frame at bottom edge on back and to the wall directly behind.  
*Chromed steel, with screws and pins included for each.*

- | Item #  | Description                    |
|---------|--------------------------------|
| TAK1030 | Anti-Swing Folding Bell Hanger |

- | Item #  | Description                  |
|---------|------------------------------|
| TAK1035 | Frame Wire Clips • Box of 50 |

Picture hanging solutions  
that set the global standard.







• Strap Hangers shown at actual size.  
• Screws are not included.

## Strap Hangers

The professional framer's preferred method for attaching hanging wire to the back of a frame. Providing heavy duty holding power, the hanger lies flat against the back of the frame, allowing the frame to hang tight against the wall. Steel hangers can be used in conjunction with picture wire, or without for heavy items when weight distribution is necessary.

• Superior quality nickel plating.

Item #	Size	Type	QTY/Box
H100	1 1/8"	1 Hole	1000
H101	1 1/8"	1 Hole	200
H102	1 1/4"	1 Hole	1000
H103	1 1/4"	1 Hole	200
H104	1 7/8"	2 Hole	1000
H105	1 7/8"	2 Hole	200
H106	1 3/4"	1 Hole	1000
H107	1 3/4"	1 Hole	200

Item #	Size	Type	QTY/Box
H108	2 1/8"	2 Hole	1000
H109	2 1/8"	2 Hole	200
H110	3 3/4"	3 Hole	1000
H111	3 3/4"	3 Hole	200

Item #	Size	Type	QTY/Box
1061B	1 1/2"	2 Hole	1000
1062B	1 1/4"	1 Hole	1000
1221	7/8"	1 Hole	2000
1222	1 1/8"	1 Hole	2000



## Flangers

For securely hanging the narrowest of wood mouldings, Flangers are designed to prevent bowing and pull-outs due to weight related stress. Available in Narrow, Medium, and Wide.

Item #	Description
932	Narrow • 50 Sets/Box
938	Medium • 50 Sets/Box
939	Wide • 40 Sets/Box
932B	Narrow • 500 Sets/Box
938B	Medium • 500 Sets/Box
939B	Wide • 400 Sets/Box

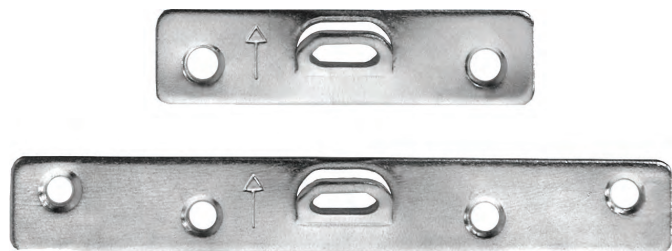

## Steel Super Hangers

Steel Super Hangers eliminates cracking and pull outs of narrow and shallow mouldings, where strap hangers may be too wide and screw-eyes are insufficient. Screw support above and below wire loop ensures balance of pressure to reduce stress on moulding. Use #6 Philips screws (not included). • 100 hangers per box.

Item #	Size	Type	QTY/Box
H112	2"	2 Hole	100
H113	3 1/2"	4 Hole	100

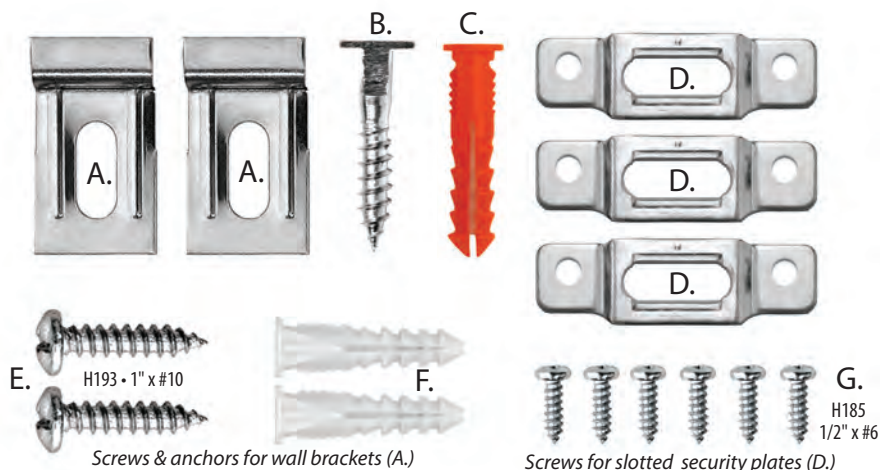

Screws & anchors for wall brackets (A)

Screws for slotted security plates (D)

## Security Hangers Set for Wood Frames

Security hangers include special brackets that attach to the frame, wall brackets, and a special T-Headed screw which locks into the slotted security plate. Hanging requires specially designed security wrench (Sold separately: see bottom of page) which turns the T-Screw 90° while hung. Polybagged set includes parts shown above: 2 wall brackets with screws and wall anchors (A), T-Screw with wall anchor (B & C), 3 slotted brackets for wood frame (screws included). Bulk quantity box of 100 sets available (Item H138)

Set consists of components shown above:

- A. Wall Support Brackets (2)
- B. T-Screw (1)
- C. Wall Anchor for T-Screw (1)
- D. Slotted Security Plates (3)
- E. 1" x #10 screws (2)
- F. Wall Anchors for 1" x #10 screws (2)
- G. 1/2" x #6 screws for slotted plates (6)

Item # Description

**H136** Wood Security Hanger Set

Item # Description

**H138** Bulk box of 100 wood security hanger sets

• Volume pricing available

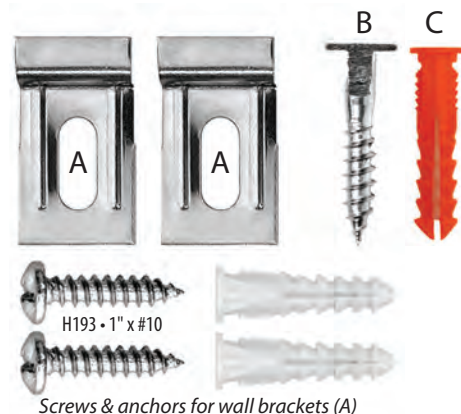

Screws & anchors for wall brackets (A)

## Security Hangers Set for Metal Frames

Security hangers sets for metal frames include wall brackets with screws and anchors, and the T-Headed screw which locks into the back channel of a metal frame. Hanging requires specially designed security wrench (Sold separately: H140, or H141) which turns the T-Screw 90° while hung. Polybagged set includes parts shown above: 2 wall brackets with screws and wall anchors (A), and T-Screw with wall anchor (B & C). Bulk quantity box of 100 sets available (Item H139)

Item # Description

**H137** Metal Security Hanger Set

Item # Description

**H139** Bulk box of 100 Metal Security sets

## Security System Hardware Components

### A: Wall Support Bracket

- 10 per pack
- Can be used with metal or wood security system

Item # Description

**H228** 10 Wall Brackets 

### B: T-Screw

- 10 per pack
- Can be used with metal or wood security system
- Also can be used with Omega Cleat system

Item # Description

**H227** 10 T-Screws

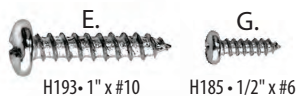

H193 • 1" x #10

H185 • 1/2" x #6

### C: Wall Anchors for T-Screw

- 10 per pack
- Sized for use with T-Screws (H227)

Item # Description

**H230** 10 T-Screw Wall Anchors

### F: Anchors for #10 Screws (wall support bracket)

Item # Description

**H231** 10 Wall Anchors for #10 screws

### D: Slotted Security Plate

- 10 per pack
- For use with wood security system
- Attaches to back of wood frames

Item # Description

**H229** 10 Slotted Plates

### E & G: Screws

Size	Item# (200 Qty)	Item# (1000 Qty)
1" x 10:	<b>H193</b>	<b>H192</b>
1/2" x 6:	<b>H185</b>	<b>H184</b>

## Security Bracket Picture Hanger

Designed for wood frames, this two-piece system securely hangs heavy frames and mirrors. The frame mounting bracket screws into the back of the frame, positioned with the prong down. The wall mounted bracket catches the prong to interlock the unit supporting and securing its weight and placement. Mechanism is not permanently locking, to allow for cleaning, painting, or maintenance. Screws sold separately. Screws needed for frame mounting bracket (4) 1/2" #6 wood screws. 4 screws needed for wall bracket will vary by picture weight. (1" #6 screws recommended).

Item # Description

**3020** Bracket for 1 frame

Item # Description

**H244** Brackets for 100 frames



## Security Wrench

Locking wrench for turning T-Screw in wood or metal security hanging systems. (2 sizes) 

Item # Description

**H140** 7" Security Wrench

**H141** 9.5" Security Wrench



All pictured actual size



## Zinc Plated Screw Eyes

Screw eyes made of zinc-plated steel for screwing into wood frames to attach wire for hanging. Available in short shank for standard depth picture frames and long shank for taller profiles and in boxes of 200 or 1000 pieces.

### SHORT SHANK

Item #	Description
H142	217 1/2 - 200 qty box
H144	216 1/2 - 200 qty box
H146	215 1/2 - 200 qty box
H148	214 1/2 - 200 qty box
H150	213 1/2 - 200 qty box
H152	212 1/2 - 200 qty box
H154	211 1/2 - 200 qty box
H156	210 1/2 - 200 qty box

Item #	Description
H143	217 1/2 - 1000 qty box
H145	216 1/2 - 1000 qty box
H147	215 1/2 - 1000 qty box
H149	214 1/2 - 1000 qty box
H151	213 1/2 - 1000 qty box
H153	212 1/2 - 1000 qty box
H155	211 1/2 - 1000 qty box
H157	210 1/2 - 1000 qty box

### LONG SHANK

Item #	Description
H158	216 - 200 qty box
H160	214 - 200 qty box
H162	212 - 200 qty box

Item #	Description
H159	216 - 1000 qty box
H161	214 - 1000 qty box
H163	212 - 1000 qty box

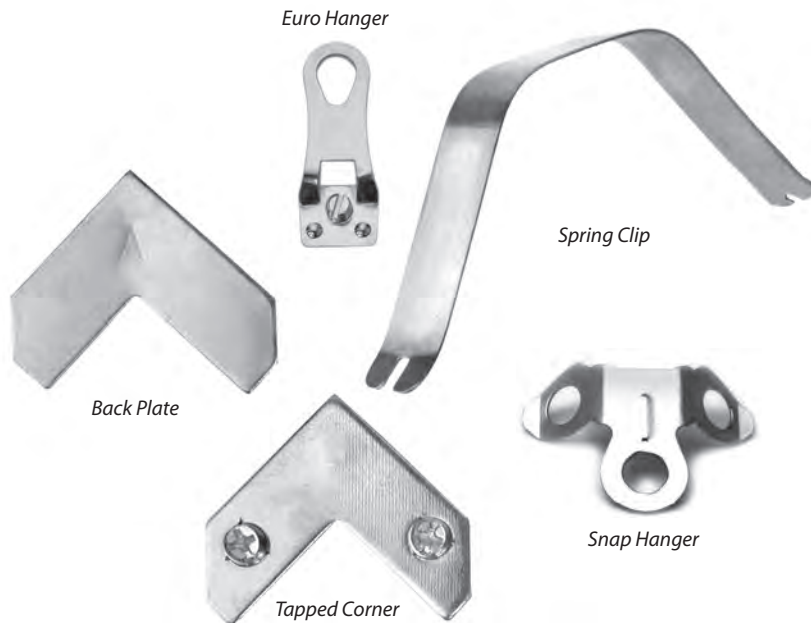

## Metal Frame Hardware

Universal metal frame hardware fits a variety of the most popular manufacturer's metal profiles. Available in polybagged sets or as individual parts to stock your supply needs.

Item #	Description
H125	Metal Frame Hardware • 1 frame polybag w/ EURO
H124	Metal Frame Bulk Pack • 100 Frame Pack w/ EURO
H116	Tapped Corners • 1000 Pieces per pack
H118	Corner Back Plates • 1000 pieces per pack
H121	Euro Hangers • 200 pieces per pack
H120	Euro Hangers • 1000 pieces per pack
H122	Spring Clips - 3/8" • 1000 clips per pack
4031B	Snap Hangers • 1000 pieces per pack



Snap Hanger



## Tapped Angles

Joins corners on metal frames with no back plate needed. Screws apply pressure on back.

Item #	Description
4031C	400 pieces per pack
4032B	1000 pieces per pack



## Articulated Angles

Angles that can be adjusted to any varying degree to join unique shapes with custom cut metal frames. Comes with 8 top plates w/screws and 16 bottom plates.

Item #	Description
4028C	8 angles w/ 16 plates 



## Offset Clips

Offset clips are the solution to fitting subject matter that exceeds the depth of a frame. Most common applications include fitting stretched canvases, liners, stacked frames, shadowboxes and 3-dimensional art. Offsets have 2 holes for maximum versatility. **Nickel plated.** (Mounting screws not included; screw size should be determined by frame depth.)

## 2-HOLE OFFSETS

Item #	Height/QTY
H233	1/8" H - 1000 qty box
H234	3/8" H - 1000 qty box
H235	1/2" H - 1000 qty box
H172	3/4" H - 100 qty box
H173	3/4" H - 1000 qty box
H174	1" H - 100 qty box
H175	1" H - 1000 qty box

## 2-HOLE OFFSETS

Item #	Height/QTY
H164	1/8" H - 100 qty box
H166	1/4" H - 100 qty box
H167	1/4" H - 1000 qty box
H168	3/8" H - 100 qty box
H170	1/2" H - 100 qty box

## Nickel Plated Steel Wood Screws with Super Sharp Tip!

### PAN HEAD Phillips Screws

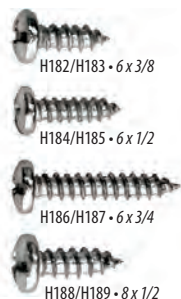
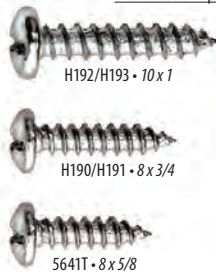

### FLAT HEAD Phillips Screws



## Wood Screws

Nickel plated steel wood screws for a variety of every day framing applications. Pan head screws with Phillips screw drive head for general use, and flat head Phillips drive screws for countersinking.

200 and 1000 quantity boxes



Size	200 QTY Item#	1000 QTY Item#
6 x 3/8	H183	H182
6 x 1/2	H185	H184
6 x 3/4	H187	H186
8 x 1/2	H189	H188
8 x 5/8	-----	5641T
8 x 3/4	H191	H190
10 x 1	H193	H192
4 x 1/2 (f)	H177	H176
6 x 1/2 (f)	H181	H180

(f) = flathead

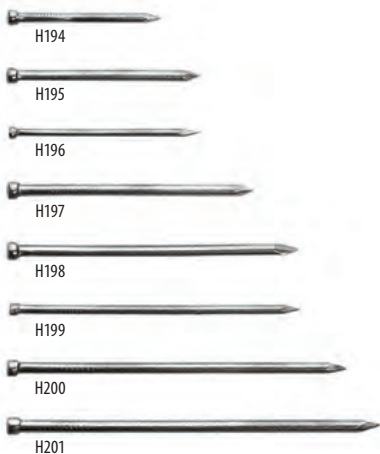

## Wire Brads

1 lb. boxes.

Item #	Size	Finish
H194	3/4" x 18	Bright
H195	1" x 17	Bright
H196	1" x 19	Bright
H197	1 1/4" x 17	Bright
H198	1 1/2" x 16	Bright
H199	1 1/2" x 18	Bright
H200	1 3/4" x 17	Bright
H201	2" x 16	Bright



## Sawtooth Hangers

Steel sawtooth hangers in 2 sizes attaches to wood frames with included nails.

Item #	Description
H130	1000 qty 1 3/4" sawtooth w/nails
H131	100 qty 1 3/4" sawtooth w/nails
H132	1000 qty 2 5/8" sawtooth w/nails
H133	100 qty 2 5/8" sawtooth w/nails



## Nailless Sawtooth Hangers

Sawtooth hangers attaches to wood frames without use of nails. Can be driven by hammer or by using Sawtooth Insert Tool (item # H134).

Item #	Description
H126	1000 qty 7/8" nailless sawtooth
H127	100 qty 7/8" nailless sawtooth
H128	1000 qty 1 3/4" nailless sawtooth
H129	100 qty 1 3/4" nailless sawtooth



## Mending Plates

Mending Plates are designed for reinforcing, attaching, and connecting wood sections. They can be used to reinforce flat surface joints and seams as well as connect or reinforce stacked frames.

Nickel or Brass finish

2" and 3 1/2" sizes, 200 quantity pack.

(Screws sold separately.)

Item #      Description

- 3800** 200 ct. 2" (2-hole) nickel
- 3801** 200 ct. 3 1/2" (4-hole) nickel
- 3805** 200 ct. 2" (2-hole) brass
- 3806** 200 ct. 3 1/2" (4-hole) brass



## Corner Angles

Flat corner angles are designed to reinforce flat right-angle corner joints, making it ideal for use on larger frames to ensure stability. The 1 1/2" and 2" braces have a satin finish that will resist tarnishing and rust.

1 1/2" and 2" sizes, 100 qty pack.

(Screws sold separately.)

Item #      Description

- H114** 100 1 1/2" corners
- H115** 100 2" corners



## Turnbuttons

Nickel plated turnbuttons are essential to framing projects with replaceable subject matter such as document, portrait, and table frames. Raised crest on one side can be used to apply more pressure to backing or easelback.

3/4" and 1" sizes, 1000 quantity pack.

(Screws sold separately.)

Item #      Description

- 4327** 1000 3/4" Turnbuttons
- 4328** 1000 1" Turnbuttons

### Nails included



## Bulk Picture Hooks w/ nails

Quality nickel plated picture hooks with nails in bulk quantity packs of 1000. 

Item #      Description

- H207** 1000 10 lb. hooks w/nails
- H208** 1000 20 lb. hooks w/nails
- H209** 1000 30 lb. hooks w/nails
- H210** 1000 50 lb. hooks w/nails
- H211** 1000 100 lb. hooks w/nails



## Courtesy Pack Polybagged Picture Hooks

Quality nickel plated picture hooks with nails individually polybagged with goodwill message for your custom framing customers.

Available in 5 sizes in 100 quantity boxes. 

Item #      Description

- H202** 10 lb hook - 100 qty box
- H203** 20 lb hook - 100 qty box
- H204** 30 lb hook - 100 qty box
- H205** 50 lb hook - 100 qty box
- H206** 100 lb hook - 100 qty box



## Double-Head Bear Claw Hanger

Self-drilling continuous thread steel screw with space for hanging wire. Holds 30 lbs. in drywall and 100 lbs. in a stud. Great for hanging with D-Rings and sawtooth hangers.

Item #      Description

- 1870** 25 Double-Head Hangers 



## Brass Picture Hooks

Attractive and strong brass plated picture hooks come with brass head tempered steel nails.

Available in 5 sizes, in 100 individual polybags or unbagged bulk sets of 100 hooks.

Nails included for each hanger.

100 polybagged hangers (items 4555A-E)

100 unbagged hangers (items 4558A-E)

### Polybagged Sets

Item#	Size
<b>4555A</b>	10 lbs.
<b>4555B</b>	20 lbs.
<b>4555C</b>	30 lbs.
<b>4555D</b>	50 lbs.
<b>4555E</b>	75 lbs.

### Bulk-Unbagged

Item#	Size
<b>4558A</b>	10 lbs.
<b>4558B</b>	20 lbs.
<b>4558C</b>	30 lbs.
<b>4558D</b>	50 lbs.
<b>4558E</b>	75 lbs.



## Moulding Hooks

Brass plated hooks designed to hang from decorative wall moulding ledge. Moulding Hooks fasten directly to your wall moulding and hold either a hanging wire, filament cord, or picture frame wire.

With the moulding at ceiling height or eye level, this hook is a quick option for hanging your art. Moulding hooks are not designed to use with stainless cable systems nor with vertical hanging rods.

2 sizes, 100 hooks per box.

Item #      Description

- 1048A** 100 Narrow Hooks
- 1048B** 100 Wide Hooks



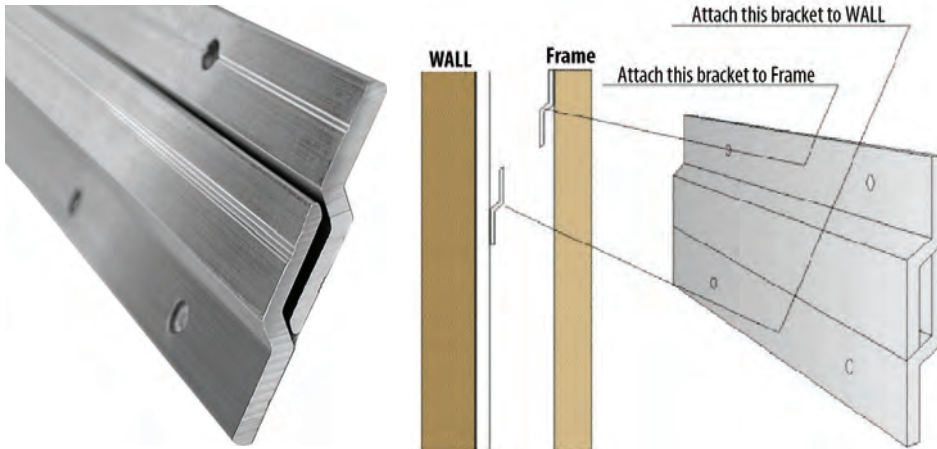

**Omega Cleat Hanging System** 

Designed to hang large, oversized and heavy objects, the Cleat hanging system is the #1 solution achieving secure, level and flush picture hanging. The system works by interlocking two bars: one for the frame and one for the wall. Use a level when attaching the wall bar to ensure a perfect hang. Made of 100% extruded aluminum with multiple 3/16" pre-drilled holes every 4 inches for easy stud positioning. For maximum strength and weight distribution, attach into wall studs. Aluminum bars can be cut to size with hand or power saw. Available in 2 weights: Regular for under 90 lbs., and Heavy for over 90 lbs. Can be used with security hardware H227, H229, and H230. Screws not included.

Item #	Package Description
<b>HZ1224</b>	(Regular) 12" Bars: 24 Pcs.
<b>HZ1224H</b>	(Heavy) 12" Bars: 24 Pcs.
<b>HZ2412</b>	(Regular) 24" Bars: 12 Pcs.
<b>HZ2412H</b>	(Heavy) 24" Bars: 12 Pcs.
<b>HZ368</b>	(Regular) 36" Bars: 8 Pcs.
<b>HZ368H</b>	(Heavy) 36" Bars: 8 Pcs.
<b>HZ486</b>	(Regular) 48" Bars: 6 Pcs.
<b>HZ486H</b>	(Heavy) 48" Bars: 6 Pcs.

Item #	Bulk Quantity Set
<b>HZ96</b>	(Regular) 58" Bars: 20 Pcs.
<b>HZ96H</b>	(Heavy) 58" Bars: 20 Pcs.



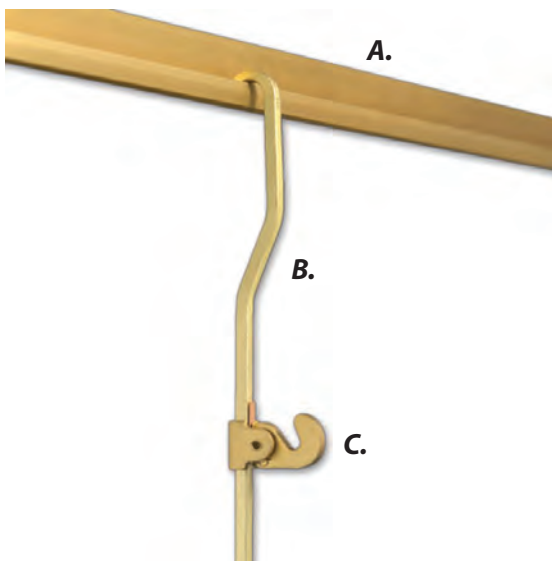

Detail of Brass Rod Hook (Monkey Hanger)

French Gallery Rod System Parts (as shown on left): (A) Brass J-Channel Wall Bracket, (B) Brass Gallery Rod, (C) Brass Monkey Hanger (detailed above).

**French Gallery Rod System** 

Engineered for uncompromising durability and beauty, the Gallery Rod system is a unique and efficient hanging solution for collections and group/gallery displays. Three-part system consists of an adjustable hook that attaches on a solid brass rod which hangs from a J-Channel bracket mounted on the wall. This allows for easy mobility and repositioning of framed pieces. Rods and channels can be easily modified to size using a hack saw.

Item #	Description
<b>5580</b>	Brass Monkey Hanger 
<b>5581</b>	J-Channel (6 feet) 
<b>5585</b>	6 ft. Gallery Rod w/ 1 hanger 
<b>5586</b>	8 ft. Gallery Rod w/ 1 hanger 



**Chartpak Touch-Up Markers** 

Industry favorite Chartpak markers are specially formulated containing wood stains of the most popular finishes. Great for touching up join lines and cut edges, or blemishes on old frames. Markers come equipped with the Tri-Nib marker point, allowing precision with fine, medium, and broad tip all-in-one. Color tones can be refined by using Chartpak's Blending Marker (item CPFTMO). Sold individually (see below) and in sets.

**Individual Colors**

Item #	Color
<b>CPFTM105</b>	Ice Blue
<b>CPFTM122</b>	Grass Green
<b>CPFTM139</b>	Light Oak/Maple
<b>CPFTM148</b>	Light Pine
<b>CPFTM160</b>	Salmon
<b>CPFTM20</b>	Evergreen
<b>CPFTM29</b>	Leaf Green
<b>CPFTM4</b>	Ultramarine
<b>CPFTM42</b>	Cadmium Yellow
<b>CPFTM5</b>	True Blue
<b>CPFTM54</b>	Dark Walnut
<b>CPFTM58</b>	Dark Oak
<b>CPFTM6</b>	Prussian Blue
<b>CPFTM60</b>	Walnut Mahogany
<b>CPFTM69</b>	Dark Cherry
<b>CPFTM70</b>	Medium Oak
<b>CPFTM74</b>	Medium Cherry
<b>CPFTM82</b>	Crimson
<b>CPFTM85</b>	Maroon
<b>CPFTM86</b>	Red Mahogany
<b>CPFTM90</b>	Wine Red
<b>CPFTM99</b>	Black
<b>CPFTMO</b>	Blending Marker



**Chartpak Touch-Up Sets** 

• Chartpak 25-marker Set

Item #	Description
<b>CPFTM25</b>	Set of 25 Markers

Chartpak 9-color Wood Tone Set

Item #	Description
<b>CPFTM9</b>	Set of 9 wood





• Nail Hole & Corner Filler 2 oz. tins



• Nail Hole & Corner Filler 1 lb. jars

## Nail Hole & Corner Filler

Amaco Nail Hole and Corner Filler is a pliable filler for nail holes, corners, cracks, and crevices in wood frames and will not dry out or shrink. Colors can be mixed to match. 2 oz. tins & 1 lb. jars.

### 2 Ounce Tins

Item #	Color	Item #	Color
NHF21408	Orange	NHF21419	White
NHF21409	Yellow	NHF21420	Light Oak
NHF21410	Turquoise	NHF21421	Blonde Maple
NHF21411	Walnut	NHF21422	Red Maple
NHF21412	Natural	NHF21423	Dk. Provincial Maple
NHF21413	Red	NHF21424	Dark Walnut
NHF21414	Green	NHF21425	Medium Maple
NHF21415	Blue	NHF21426	Grey
NHF21416	Mahogany	NHF21427	Gold
NHF21417	Ivory	NHF21428	Silver
NHF21418	Black	NHF21429	Dark Gold

### 1 lb. Jars

Item #	Color	Item #	Color
NHF21458	Orange	NHF21470	Light Oak
NHF21461	Walnut	NHF21471	Blonde Maple
NHF21462	Natural	NHF21473	Dk. Provincial Maple
NHF21463	Red	NHF21474	Dark Walnut
NHF21464	Green	NHF21475	Medium Maple
NHF21465	Blue	NHF21476	Grey
NHF21466	Mahogany	NHF21477	Gold
NHF21467	Ivory	NHF21478	Silver
NHF21468	Black	NHF21479	Dark Gold
NHF21469	White		



## Rub 'N Buff

Rub 'n Buff is formulated from carnauba waxes, fine metallic powders, and select pigments, for touching up metallic finishes on frames or embellishing highlights. Can be blended to achieve desired finish. 0.5 oz (15ml) tubes 

- RNB76361 Gold Leaf
- RNB76362 Antique Gold
- RNB76366 Antique White
- RNB76368 Spanish Copper
- RNB76369 Ebony
- RNB76370 Silver Leaf
- RNB76371 Grecian Gold
- RNB76372 Autumn Gold
- RNB76379 European Gold
- RNB76380 Pewter



## Brush 'N Leaf

Brush 'n Leaf Metallic Finishes go on easily with one application. Just brush it on any clean, dry & solid surface. The exclusive Brush 'n Leaf formula features metallic flakes that "leaf" into a solid, shiny metallic look that dries quickly to a durable finish. Great for touching up brighter metal leaf finish frames. 1 oz. jar 

- | Item #   | Color        |
|----------|--------------|
| BNL76630 | Gold Leaf    |
| BNL76631 | Antique Gold |
| BNL76632 | Silver Leaf  |



## Treasure Gold

In one simple step, Treasure Gold® gives any project a rich metallic luster as beautiful as precious metals themselves. Just rub on for glimmering highlights or to touch up gold leaf finishes. 3 ml. container 

- 4144-1 Classic Gold
- 4144-2 Florentine Gold
- 4144-7 Pewter
- 4144-8 Silver



## Liquid Leaf

Liquid Leaf helps create the beauty of traditional leafing with brush on ease. Paint combines an undercoating with metallic color for a brilliant, long lasting finish. Use on wood, metal, glass, ceramics, paper, plaster or plastic. 3/4 oz. jar 

- 4145-1 Gold
- 4145-2 Florentine Gold
- 4145-3 Renaissance Gold
- 4145-5 Brass
- 4145-6 Copper
- 4145-8 Silver



Items with this symbol "Ride Along" with your length or chop moulding order at no extra delivery charge.



Items with this symbol are Special Order from the U.S.



**Z-Gel Texturizing Finishing Medium**

Z-Gel is the one step texturing process for posters, prints, and pre-treated photos, is a great alternative to canvas transfers, and eliminates the need for glass. You control the brush-stroked appearance. No prep work needed, simply mount prints directly on firm substrate and apply the Z-Gel gloss medium with a brush to create painterly or stippled effects. Cleans up with soap and water.

*Gloss or Semigloss finish, 32 fluid oz. or 1 Gallon* 

Item #	Size/Description
ZG32G	Gloss Z-Gel Medium, 32 oz.
ZG32S	Semigloss Z-Gel Medium, 32 oz.
ZG64G	Gloss Z-Gel Medium, Gallon
ZG64S	Semigloss Z-Gel Medium, Gallon



**Z-Crackle Antiquing Medium Starter Kit**

Z-Crackle Finish provides an excellent antique crackling system for posters, prints and eliminates the need for glass. You control the thickness of the cracks through the application of the Step 1 finish. Mount prints directly to illustration board and other firm substrate. Z-Crackle Finish creates a 100% acrylic polymer emulsion, yielding excellent flexibility and water protection. Cleans up with soap and water. *Not suggested for photographs or giclee prints. Kit includes items shown:*

*16 oz. Step 1 Crackle Finish, 16 oz. Step 2 Crackle Activator, 2 oz. Antiquing Polish, and sponge brush*

Item #	Size/Description
ZCKIT	Z-Crackle Starter Kit 



Solid Panel Velour Easel Back



Door-Hinged Velour Easel Back

**Velour Easel Backs** 

High quality flocked velour easel backs are constructed with the sturdiest substrate in the industry. Solid easelbacks come in a variety of standard sizes and can be trimmed for customization. Door-hinged easel backs are available in 4 sizes with door openings in standard sizes of 4x6, 5x7, 8x10, and 11x14. Hinged panels are equipped with turnbutton closures for easy fitting and refitting of contents. Velour easel backs are the ideal choice for constructing high-end table frames. *Easel stands vertically & horizontally. Pack of 6 Easel Backs*

**Velour Solid Panel - Great look for a great price**

Item #	Size/Description
EBV46	4 x 6 Velour Easel Back
EBV57	5 x 7 Velour Easel Back
EBV810	8 x 10 Velour Easel Back
EBV1114	11 x 14 Velour Easel Back

**Door-Hinged Velour Easel Backs - easy access fitting**

Item #	Size/Description
EBVD46	4 x 6 door opening
EBVD57	5 x 7 door opening
EBVD810	8 x 10 door opening
EBVD1114	11 x 14 door opening

**Embossed Easel Backs** 

Sturdy embossed leather-look easel backs are made of vinyl coated compressed card-core for durability and stability with thick easel stands reinforced with metal hinges. Available in standard sizes, panels can be easily cut to custom sizes. *Easel stands vertically & horizontally. Pack of 6 Easel Backs*



Item #	Size/Description
EB46	4 x 6 Embossed Easel Back
EB57	5 x 7 Embossed Easel Back
EB810	8 x 10 Embossed Easel Back
EB1114	11 x 14 Embossed Easel Back



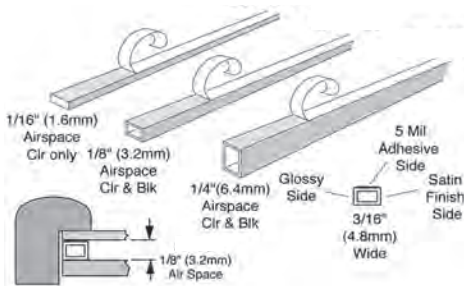
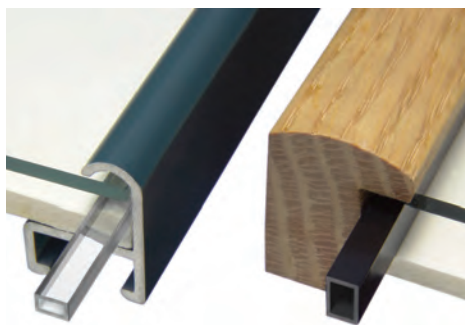

## Econospace

Neutral pH hollow plastic "peel & stick" spacer that is used to make the proper airspace between the art and glass in either wood or metal picture frames. EconoSpace is easy to trim to size by hand. *Clear, or Black. Bundled in 60' or 100' packs of 5-foot lengths. 3/16" wide strips in 4 spacer depths.*

Item # Height-Color • total

- FRS-8** 1/4" Clear • 60'
- FRS-9** 1/4" Black • 60'
- FRS-5** 1/16" Clear • 100'
- FRS-6** 1/8" Clear • 100'
- FRS-7** 1/8" Black • 100'

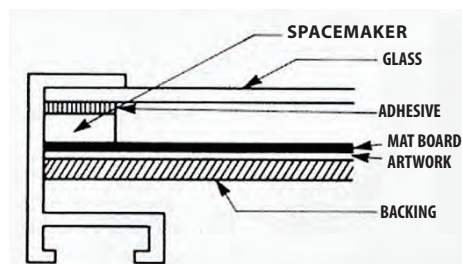

## Spacemaker

An economical acid-free solid plastic picture frame spacer that is coated on one side with a strong pressure sensitive adhesive for ease of application. Can be stacked to increase height/space. Works equally well in both wood and metal frames. Available in 1/8" and 1/4" depths, each length is 3/16" wide x 58" long. Spacemaker can be easily cut to size by scoring and snapping by hand. *Black, or Clear*

Item # Height-Color • total

- 5151B** 1/8" Black • 21 pcs
- 5151C** 1/8" Clear • 21 pcs
- 5152B** 1/4" Black • 11 pcs
- 5152C** 1/4" Clear • 11 pcs

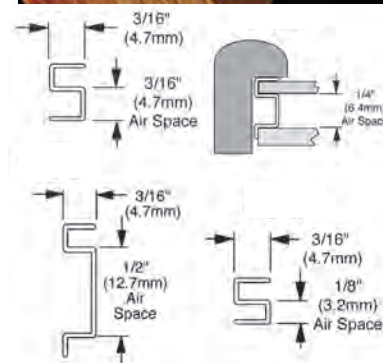
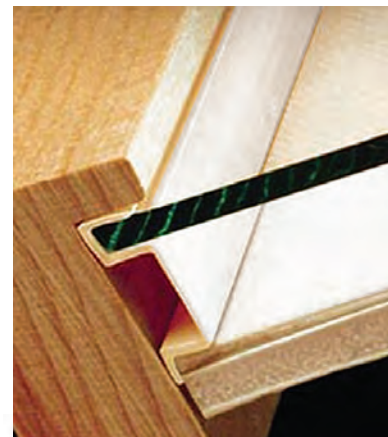

## Framespace

Framespace is an adhesive-free plastic spacer that works by capping the edge of the glass and braces the rabbet of the frame, separating the glass from the surface of the artwork by 3/16" - 1/2". Plastic strips can easily be trimmed to size by hand using a blade. *Clear, Black, or White. Bundled in 60' or 100' packs of 5-foot lengths. 3/16" wide strips of various spacer depths.*

• *Framespace fits on the edge of glass; consider the thickness of glass or acrylic when using Framespace.*

### Fits 2mm glass & 1/8" acrylic:

Item # Height-Color • total

- 5111** 3/16" Clear • 100'
- 5111C** 3/16" White • 100'

### Fits 2.5mm glass & 1/8" acrylic:

Item # Height-Color • total

- 5110A** 3/16" Clear • 100'
- 5112A** 1/2" Clear • 60'
- 5112C** 1/2" White • 60'
- 5118A** 1/2" Clear • 60'



## Rabbetspace

Rabbetspace is a simple yet ingenious full frame rabbet depth extender system. Neutral pH acrylic has a black satin finish. When backing projects with black foam board or mat board, you'll achieve a very professional looking appearance with no paper backing required. Also works beautifully with easel backs. 35 feet: (7) 5 ft. lengths per set. *150 matching black screws included.*

Item # Height-Color • total

- FRS-1** 1/8" Black • 35 feet
- FRS-2** 1/4" Black • 35 feet
- FRS-3** 3/8" Black • 35 feet
- FRS-4** 1/2" Black • 35 feet



Items with this symbol "Ride Along" with your length or chop moulding order at no extra delivery charge.



Items with this symbol are Special Order from the U.S.





## Self-Adhesive Bumpers

Non-marking, adhesive silicone bumpers keep the bottom corners of frames properly spaced out from the wall while helping to stabilize placement while hung. For use with wood (all items) and metal frames (H213) • 1000 per pack

Item #	Description
H212	Clear Round • 1000pcs
H214	White Round • 1000pcs
H215	Black Round • 1000pcs
H216	Brown Round • 1000pcs

### For Metal Frames

H213	Clear Sphere • 1000pcs
------	------------------------



## Canvas Wrap & Gallery Hangers

Canvas Gallery Wrap Hangers are designed for stretched canvases and frames with a recessed back. Gallery Hangers work with frames with a flush or papered back. Hangers for hollow backs fit stretchers and frames with hollow backs of 1/16" + deep, & moulding 3/4" + wide. Flush Back hangers have a protuded step to allow for wall hanger. Screws not included 

Item #	Description
6925B	200 Gallery Wrap Hangers for stretchers/hollow back frames
6926B	200 Gallery Hangers for flush or papered frame backs



## Hangman Heavy Duty Hanger

Hangman's Heavy Duty Hanger with Wall Dog® screws, quickly and easily hangs mirrors, pictures and wall decor up to up to 100 lbs. (10"), 200 lbs. (18") or 300 lbs. (30"). The Hangman System supplies all the hardware needed for wall installation and includes a handy removable bubble level. Brackets are made of strong heavy-duty aluminum. Mounting holes are punched on 4-Inch centers for easy installation into studs. Polybagged for resale.

Item #	Description
1831D	10", 100 lb. hanger
1832D	18", 200 lb. hanger
1833D	30", 300 lb. hanger



## Hangman 5" Canvas Hanger

The Hangman Canvas Hanger is a two piece bracket system that hangs giclees, gallery wraps, canvas or open back frames flush to the wall. The wall track includes a bubble level for an accurate installation. 5 inch hanger holds up to 30 lbs. 

Item #	Description
1790	5", 30 lb. Canvas Hanger



## KWIK Hangers

Kwik Hangers are a safe fast way to hang posters and signage mounted on foam or corrugated board. Bendable metal tab hangs easily. 100 hanger pack 

Item #	Description
4092	100 KWIK Hangers



## Swiss Clips

Spring loaded arms clamp and hold together any thickness up to 3/8" combination of glass, picture, mat, and backing. Requires the rigidity of the glass and backing board. Clips can be use to frame any size within 30" x 30" plus one hanger bracket.

Item #	Description
4737	Pack of 4 Clips
4739	Bulk Pack of 100 Clips



## Swiss Corner Clips

Corner Clips work with a nylon cord, holding its contents together by tension. Holds together any thickness up to 3/8" combination of glass, picture, mat, and backing. System can support up to 60 lbs. and up to 30" x 30". Kit includes four corner clips, cord, and hanger bracket.

Item #	Description
4735	Swiss Corner Clips Kit
4734	150 ft. of Cord
4736	Bulk Pack of 60 Corners



## Plastic ZiG-ZaG Hangers

Plastic Zig Zag hangers are the most popular way to hang foamboard mounted posters and signs. Simply peel the plastic tab, stick on the back, & hang on small nail or hook. 100 hanger pack

Item #	Description
5280	100 Zig Zag Hangers

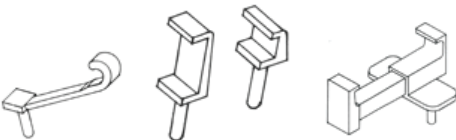
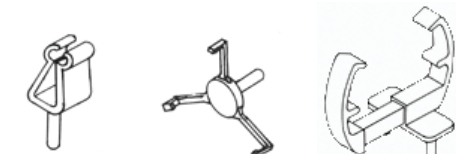

Plate Holder

Multi-purpose Holder

Knife Holder



Spoon Holder

Coin Holder

Gun Holder

## Mighty Mounts

Using glue or wire adds time to the construction of a shadow box. This process can compromise or even damage the object and in time, the glue can give away, allowing the object to come loose in the frame. Mighty Mounts are polycarbonate pH neutral plastic devices that have a stem that is quickly and easily placed through mat board and foam board backing to hold the object securely in the shadow box. To assemble, first lay out your objects in a shadow box the way you want them to be viewed. Second, take an awl and place a hole at the desired location through the backing. Place the stem of the Mighty Mounts through the hole and place a speed nut on the back to hold it in place. Once your holders are in place, attach your object and it is ready to frame.

Item #	Description	Qty.
4255	Spoon/ Object Clip Holder	12
4256	Knife Mount	1
4257	Coin Holder	12
4258	Gun Mount	1
4259	Multi-purpose Clip Holders	12
4260	Plate Holder / Bracket Clip	12



## Center-Finding Tape Measure

Omega's solid-state 16-foot retractable center-finding tape measure is cased in a heavy-duty housing with handy metal belt clip and locking mechanism. Easily find your center with 1/2" increment-reads on the bottom of tape. 3/4" x 16' metal tape

Item #	Description
UST1	Center Finding Tape Measure



## Metal Straight Edge Rulers

Durable and reliable metal straight edges for the workshop or the design desk, these rulers are made of heavy-duty aluminum that stands up to years of wear and tear. Each is marked with easy-to-read gradations in American and/or metric units of measurement. 60" and 72" lengths

Item #	Description
2025G	60" Metal Straight Edge
2025H	72" Metal Straight Edge



## Burnishing Bone

Useful for smoothing bevels on mat cuts and equally handy for burnishing and creasing heavy papers, applying decorative tapes, and smoothing raised fibers on rag mats. No framer can be without it. 

Item #	Description
N37325	6" Burnishing Bone



## Chrome Canvas Pliers

These chrome-plated steel canvas pliers, are the most essential tool for mounting your own canvases. The spring-loaded serrated jaws keep a firm grip on the canvas and open to a width of 2 3/8".

Item #	Description
CP7400	Chrome Canvas Pliers



## Premium Canvas Pliers

This premium tool features rubberized handles for comfort and a non-slip spring-loaded rubberized jaw that won't tear or crimp the canvas. Made of chrome-plated steel and built to last, these pliers have become the framer's favorite for stretching canvases by hand.

Item #	Description
CP7401	Premium Canvas Pliers



## Super Shears by Dahle (8")

These commercial grade shears can handle the toughest material as well as the most delicate fabric. They feature Solingen steel cutting blades that are machine ground and hardened to 56 Rockwell. This specification is considered the optimal hardness of metal for maintaining a sharp edge, essential for the rigors of a frame shop.

Item #	Description
6150	8" Dahle Super Shears





**Alvin Dusting Brush**

Traditional draftsman's dusting brush made of soft 100% sterilized horsehair, wax set in a durable 14½" wooden handle. Use for delicate dusting of artwork, platens, mats, foam boards, and glass.

Item #	Description
DB100	Alvin Dusting Brush



**Static Discharge Brush**

Kintronics StaticWisk anti-static brush is used to brush away fine dust and debris from acrylic, glass, and other materials that attract dust. The unique blend of soft natural hairs and conductive synthetic fibers plus the conductive nature of the construction result in effective static dissipation.

Item #	Description
255	StaticWisk anti-static duster



**Grounded Anti-Static Brush**

This Kintronics 4" StaticWisk Anti-Static Brush is equipped with a grounding cable which effectively removes any static charges from the surface. Brush can be cleaned with water and (if needed) mild detergent without this influencing their anti-static effect. Remove cable when cleaning.

Item #	Description
25W	StaticWisk w/grounding cable



**Cotton Gloves**

For handling delicate items of value, these cotton gloves protect surfaces from fingerprints & oils. Made of unbleached stretched cotton that can be used multiple times. 6 pairs (12 gloves), One size fits most.

Item #	Description
CG1200	Cotton Gloves 12-pack (6 pairs)



**Speck Grabber**

Great for removing individual contaminants from delicate surfaces this narrow tool can get into and in between small spaces. When the Speck Grabber is put in contact with the particle, it adheres to the particle, while leaving no residue on the contacted surface. Tips can be cleaned with mild soap and water and comes in a handy storage tube. 2 Speck Grabber tools included

Item #	Description
135SG	2 Speck Grabbers



**Document Cleaning Pad**

Specially formulated cleaning pad emits a super soft grit free powder which cleans by absorbing by surface dirt in the powder. After cleaning, residue is simply brushed away.

Item #	Description
4507	Lineco Document Cleaning Pad



**Sprayway Lint & Dust Remover**

Pinpoint accuracy makes it easy to clean hard-to-reach places. Moisture-free air blasts away lint, dust, tiny fabric scraps, sawdust, etc. Leaves no film or residue. Great portable solution for precision removal of particles and debris, ideal for cleaning equipment such as mat cutters, wall cutters, dry mount presses, and anything around your frame shop.

10 oz., Non-flammable

Item #	Size
SP805	10 oz. can



**High Performance Microfiber Cloth**

Polyester Micro Fiber absorbs up to 7 times its weight, traps dirt and dust, industrial strength, soft and absorbent, non-scratching, lint-free. Washable & reusable blue cloth in poly bags. Ideal for cleaning specialty and plain glass.

Available individually or in packs of 12

Item #	Description
1980	Performance Microfiber Cloth (1)

Item #	Description
1982	Performance Microfiber 12-pack



**Tiger Cloth® Anti-Static Cleaning Cloth**

Special microfiber cloth that has been specifically engineered for cleaning photography, delicate artwork, acrylic and glass. The 10" x 18" orange cloth has stripes of effective conductive fibers knit every 1/8" that dissipate static charges.

Item #	Description
131	Tiger Cloth anti static cloth





**Wypall Heavy Duty No-Lint Wipes Roll**

Jumbo roll of 950 cloth-like paper towels of the highest quality. The all-purpose towels are great for every use in the frameshop and are soft enough to use on specialty glass and acrylics without scratching the finish or leaving lint from paper fibers. Absorbant and strong enough to use multiple times before disposing saving resources, time and money. Roll stand available, Item WMA800 (below)

*Item # Description*

**WMA750** Wypall 950ct. Roll



**Wypall Shop Stand Dispenser**

Portable, high-capacity metal shop stand and dispenser for Wypall jumbo rolls of No-Lint wipes is compact enough for use in most any location around your workstations. Easel style folding frame stands on the floor at a comfortable convenient height. Easy loading and dispensing of rolls. 16.75" w x 18.5" d x 33" h

*Item # Description*

**WMA800** Wypall Shop Stand Dispenser





**Wypall L30 & L40 Wipes**



Ideal for cleaning glass, acrylic, and a multitude of cleaning tasks. Strong and absorbant. One-at-a-time handy dispensing package. Manufactured using 40 percent post-consumer recycled fiber. L30 wipes are light weight, great for cleaning glass & equipment. L40 are softer and thicker; well-suited for cleaning acrylic and for multiple uses.

Wypall L30 General Purpose - 100 16.4" x 9.8" wipes.  
Wypall L40 All-purpose - 100 16.4" x 9.8" wipes.

*Item # Description*

**4027** Wypall L30 Wipes • 100 ct.  

*Item # Description*

**9217** Wypall L40 Wipes • 100 ct.  



**Wypall Heavy Duty No-Lint Wipes Box**

Counter-Top box of 100 heavy-duty no-lint wipes is a great portable 'on-the-go' option for outfitting your workstations with these high-quality wipes. The all-purpose towels are great for every use in the frameshop and are soft enough to use on specialty glass and acrylics without scratching the finish or leaving lint from paper fibers. Absorbant and strong enough to use multiple times before disposing saving resources, time and money. 

*Item # Description*

**WMA100** Box of 100 wipes



**M-Tork Towels**

Designed specifically for the Tork center feed towel dispenser system (Item 4020), these high-quality, highly absorbant paper towels are great for a multitude of uses around the workshop including glass cleaning or cleaning up glues and liquids near the joiner, where you need fast one-handed dispensing. Made from 100% recycled fiber, 600 sheets per roll

*Item # Description*

**4021** M-Tork Towels  



**M-Tork Center-Feed Dispenser**

The M-Box dispenser features a high-capacity, centerfeed towel dispensing system. It is ideal for workshops and other environments where cleaning wipes need to be easily accessible and easily dispensed single-handedly. System easlily loads and disributes perforated M-Tork towels for convenient use. Mounts to wall with provided hardware.

*Item # Description*

**4020** M-Tork Towel Dispenser  



**Glass Handling Gloves**

These coated fabric gloves are covered with high quality embossed rubber offering durable protection, grip, and flexibility when handling glass.

1 pair • One size fits most.

Item # \_\_\_\_\_ Description \_\_\_\_\_

**GLASGLOV** Glass Handling Gloves (pair)



**Glass Cutter Hand Tool**

This steel wheel hand held glass cutter is a reliable tool that allows you to freely make glass cuts using a straight edge or for freehand scoring special shapes. With a comfortable zinc die cast handle with ball ended shaft for easy pivoting, and slotted head for snapping edges.

Item # \_\_\_\_\_ Description \_\_\_\_\_

**H232** Glass Cutter hand tool

**DIAMANTOR**



#1 TOP SELLER

**Diamantor® Glass Cutter**

The Diamantor Wood Handle Glass Cutter features a precision ground steel cutting wheel set into a nickel plated cutting head which is attached to a solid wood handle.

Item # \_\_\_\_\_ Description \_\_\_\_\_

**GC100** Diamantor Glass Cutter



**Acrylic Scoring Tool**

This tool is used to score acrylic by hand. Also can be used to score tempered and corrugated cardboards. Scoring blade is double-beveled ground, and has a vinyl no-slip cushioned grip handle. Use with straight edge for precise scoring.

Item # \_\_\_\_\_ Description \_\_\_\_\_

**PLEXCUT** Acrylic scoring tool



**Glass Breaking Pliers**

Used for "running" the glass along the score lines. Very light to use. Perfect for all levels of craftsman. Makes running your scores a snap.

Item # \_\_\_\_\_ Description \_\_\_\_\_

**GLPL100** Glass Breaking Pliers

**Chip Breakers & Scrap Supports**

In the event that a moulding is chipping on the back side in the process of being cut, there are a number of possibilities that could cause the the moulding to chip that is not the cause of defective moulding. Dull blades, a damaged blade tooth, cutting speed, a worn Chip Breaker or Scrap Support, etc. are all things that can contribute to chipping or blown-out cuts. Chipping and blow-out are undesirable rough-edge cuts where the wood or gesso gets chipped off of the back edge of the moulding as the saw blade exits through the surface. Some woods or gessos are more delicate and thus more subject to chipping than others. Chipping or blow-out mainly occurs when there is a gap (or void) between the blade and the Chip Breaker. Worn, overused Chip Breakers are the main cause of chipping and blow-outs and very rarely indicates bad moulding.

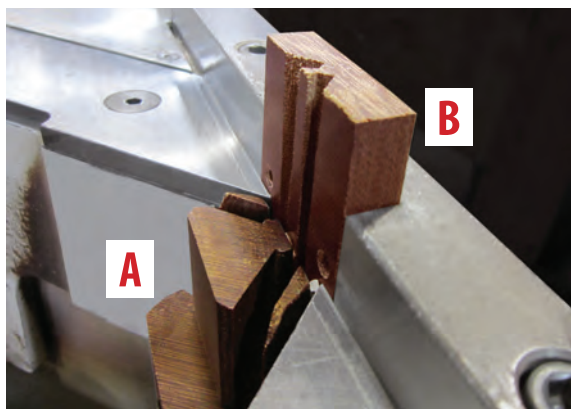

Scrap Support (A) and Chip Breaker(B) inserted in a double miter saw.



Scrap Support

**Scrap Support**

• For Pistorius Saws

A Scrap Support is a specially shaped piece of phenolic resin that sits into the throat of a double miter saw, that supports the area of moulding that is the miter cut of the moulding. The top of the support sits flush with the table providing a stable base which fills the void of the miter space. Primarily, the support keeps the miter scrap in place, keeping it from interfering with the blade. Additionally it prevents blowout and chipping on the bottom and bottom back edge by prohibiting downward movement of the moulding. Used in tandem with a viable Chip Breaker, you will achieve clean, consistent results at the saw.

Item # \_\_\_\_\_ Description \_\_\_\_\_

**SCRAPSUP** Phenolic Scrap Support



Chip Breaker

**Chip Breakers**

• For Pistorius Saws

A Chip Breaker is a block of phenolic resin that sits inside the fence of a miter saw and aids in cleanly cutting mouldings by filling any gap that may occur between the back edge of a moulding and the cutting fence. Chip Breakers are approximately 2" x 2 1/4" in size and range from 1/2" to 3/4" thick. They are held into the saw fence by two allen key bolts. Chip Breakers are wear items, and must be replaced regularly to ensure consistent clean cutting.

Item # \_\_\_\_\_ Description / Dimensions \_\_\_\_\_

**CHPBKR** Chip Breaker for MN200 • 2" x 2 1/4" x 1/2"

**CHPBKR14** Chip Breaker for 14" saw • 2" x 2 3/4" x 3/4"



**Hand Miter Cutter**

Easily cuts balsa and bass wood strips up to 1/2" thick. Great tool for cutting spacers and plastic fillets. Cuts angles precisely from 45° to 120° with mitered 45° bevels. Cast aluminum angle plate with English and metric markings. Features built-in safety lock and no-slip rubber grips for a comfortable, textured hold. Carbon steel cutting blade.

Item # \_\_\_\_\_ Description \_\_\_\_\_

**MITERCUT** Hand Miter Cutter

Items with this symbol are Special Order from the U.S.

Items with this symbol "Ride Along" with your length or chop moulding order at no extra delivery charge.









## Hot Melt Glue Gun

Dual temperature glue guns are ideal for a wide range of framing projects. Featuring a high and low switch, you can use the high temperature setting for better bonding to heavier items such as metals, plastics and wood. Use low temperature for bonding delicate material such as lace, ribbon, foam and lightweight fabric. A great tool for composing 3-dimensional project mounting in shadowboxes. • 40 watts, 120 volts • Uses 7/16" diameter glue sticks.

Item #	Description
GLGUN270	Dual Temperature Glue Gun



## Item # 7/16" Diameter Glue Sticks:

GLSTK20	All-purpose 4" glue sticks (20 per bag)	
GLSTK50	All-purpose 4" glue sticks (50 per bag)	
GLSTKF12	Fabric Stik 4" glue sticks (12 per bag)	
GLSTKW12	Wood Stik 4" glue sticks (12 per bag)	
GLSTKB12	High-Temp 4" glue sticks (12 per bag)	



## Attach-EZ® Mounting System

Attach-EZ® offers a line of products that will enable framers to easily mount almost all types of fabric & 3D work. Attach-EZ Mounting Systems have been called the framers best friend by framers around the world. The totally reversible methods and educational DVD (which is included in the kit) now allow labor intensive projects to be completed in a fraction of the time, while still maintaining archival quality standards.

Item #	Description
AZ4005C	Attach-EZ Starter Kit

- **ATTACH-EZ® Starter Kit** with 10" case & instructional DVD for fabric mounting only: 1 Fine Fabric Tool, 1 Micro Stitch Tool, 1200 Black & 1200 White Micro fasteners (4.4mm, 5.4mm, 6.4mm), 2 Micro needles, 3000 Fine Fabric Fasteners (3.5, 5, 7, 9, & 11 mm), 3 Fine Fabric standard needles & 2 short Fine Fabric needle for the 3.5 & 5 mm, written instructions, DVD and 10" Case.



## Self-Healing Cutting Mats

Five layers of PVC give these cutting surfaces maximum self-healing capability and prolonged life. Non-blunting surface material keeps cutting blades from becoming dull. Each mat contains inch and metric measurements and angle cuts on the top surface, as well as 1/2" gridlines, making them the perfect work surface for precision cutting. Either side can be used as a cutting surface. Small cuts made with sharp blades almost disappear. Do not use with utility knives, (i.e. cutting hard boards) as deep gouges will not heal. Cutting tools suited for paper such as Xacto style pen knife or razors are ideal.

Item 6171 - 24" x 36" Cutting Surface  
Item 6169 - 40" x 60" Cutting Surface

Item #	Description
6171	24" x 36" Self-Healing Cutting Mat
6169	40" x 60" Self-Healing Cutting Mat

## ULTIMO II®

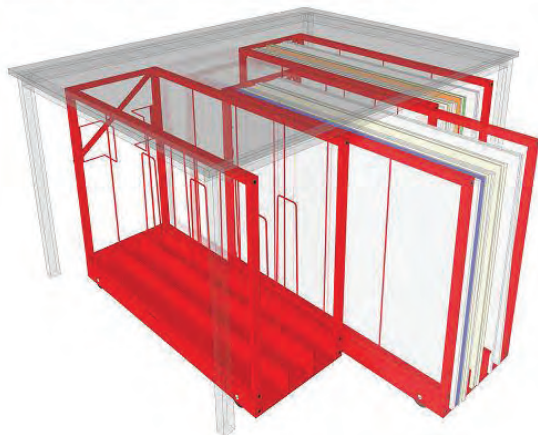

## Ultimo II Foam & Matboard Storage Cart

Storing mountboard between dividers under a workbench is standard practice by many framers. But keeping those boards neat and tidy is a challenge, especially extracting smaller pieces which tend to get pushed to the back. The Ultimo II is a stable and free rolling cart with three mounting board storage slots. The light but rigid steel structure rolls under a workbench on four large wheels hidden inside the chassis. The board is kept upright by vertical dividers. Ultimo II carries up to 160 standard size foam boards, 44" x 32".



Ultimo II rolls on 4 large plastic wheels hidden in the chassis.

The Ultimo II can also be used to safely store mounted prints. It is not designed to store heavy materials such as glass or acrylic. The unit rolls under any bench with 34" or more clearance. It is carefully packed and comes complete with full instructions for assembly and usage.

• Dimensions 1206 x 855 x 375mm

Item #	Description
3200	Ultimo II Storage Cart



Items with this symbol "Ride Along" with your length or chop moulding order at no extra delivery charge.



Items with this symbol are Special Order from the U.S.



## Kraft Paper

All-purpose, strong and budget-friendly backing papers to seal the back of the frame to prevent the encroachment of dust and debris while transporting and for its life on the wall. Also used as a durable wrapping paper for finished projects or when storing or interleaving. Spooled to fit on all standard paper roll dispensers/cutters. Available in natural/brown and in black for a more refined look, and in 40 lb. and 50 lb. weight. Strong virgin paper stock.



### • 40 lb. Natural/Brown Kraft Paper Rolls

Item #	Description
<b>KP1540</b>	15" Natural Kraft • 40 lb.
<b>KP3640</b>	36" Natural Kraft • 40 lb.

### • 50 lb. Natural/Brown Kraft Paper Rolls

Item #	Description
<b>1037D</b>	24" Natural Kraft • 50 lb.
<b>1037F</b>	30" Natural Kraft • 50 lb.
<b>KP3650</b>	36" Natural Kraft • 50 lb.
<b>KP4050</b>	40" Natural Kraft • 50 lb.
<b>KP4850</b>	48" Natural Kraft • 50 lb.

### • 50 lb. Black Kraft Paper Rolls

Item #	Description
<b>KPB2450</b>	24" Black Kraft • 50 lb.
<b>KPB3650</b>	36" Black Kraft • 50 lb.
<b>KPB4850</b>	48" Black Kraft • 50 lb.

## Vertical Kraft Paper Dispensers

Floor standing vertical paper cutter that conveniently saves workspace due to its smaller footprint and as an alternative to table top dispensers. Vertical stand dispensers are especially helpful for storing and dispensing larger, heavy rolls. Easy drop-in loading. Base has sockets for adding wheels if desired.

Item #	Description
<b>KPD27V</b>	Vertical Dispenser for 18" - 24" rolls
<b>KPD36V</b>	Vertical Dispenser for 30" - 36" rolls
<b>KPD48V</b>	Vertical Dispenser for 40" - 48" rolls

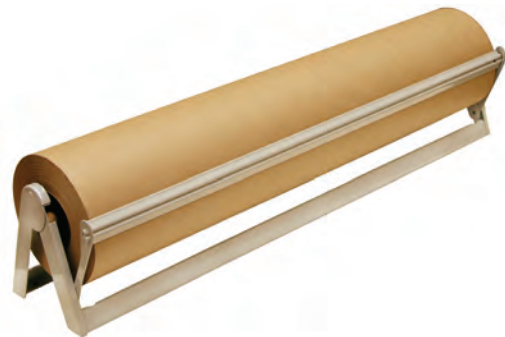

## Mountable Kraft Dispensers

Mountable kraft dispensers are a great alternative to standing and table models allowing you to mount to a table, wall or other vertical surface near your fitting or wrapping station. Strong all steel construction.

Item #	Description
<b>KPD36</b>	Wall Mount Dispenser for 36" rolls
<b>KPD40</b>	Wall Mount Dispenser for 40" rolls

## All-In-One Kraft Paper Dispensers

All -One-Dispensers are designed to have dual purpose as a table-top kraft dispenser and paper cutter, and as a plastic bag dispenser for rolled bags. Durable and simple, these all-steel dispensers are a snap to set up - just unfold the base and set on the counter and you're ready to load kraft paper or plastic bag rolls.

Item #	Description
<b>KPD15A</b>	All-In-One Dispenser for 15" rolls
<b>KPD24A</b>	All-In-One Dispenser for 24" rolls
<b>KPD36A</b>	All-In-One Dispenser for 36" rolls
<b>KPD40A</b>	All-In-One Dispenser for 40" rolls



## Standoff Hardware

Standoffs can be used to mount panels and is installed on a permanent surface to create a raised impression. These aluminum panel hardware can be used with acrylic, metal, glass, wood or any other materials. Installation of these sign mounts is easy and the cost is minimal. The aluminum standoffs can be used to clamp two clear panels together to create a poster sleeve. The panels can be easily removed, by unscrewing the standoff caps, anytime when changing the poster. These panel mounting hardware can be used to stack layers of graphic panels for an eye-catching effect. *Satin & polished*



<i>Item #</i>	<i>Finish</i>	<i>Diameter</i>	<i>Length</i>
<b>SOF1</b>	<i>Satin</i>	3/4"	3/4"
<b>SOF2</b>	<i>Satin</i>	3/4"	1 3/4"
<b>SOF3</b>	<i>Satin</i>	3/4"	2 1/2"
<b>SOF4</b>	<i>Satin</i>	1"	1"
<b>SOF5</b>	<i>Polished</i>	3/4"	3/4"
<b>SOF6</b>	<i>Polished</i>	3/4"	1 3/4"
<b>SOF7</b>	<i>Polished</i>	3/4"	2 1/2"
<b>SOF8</b>	<i>Polished</i>	1"	1"



## Print Holders

Ideal for displaying, storing and protecting artwork, documents, prints, posters, and much more. These ultra-light and super-strong sleeves are made from heavy-duty 10 mil rigid clear flexible vinyl with reinforced double stitched binding on all sides. The opening is on the short side. Includes a removable two-sided white acid-free cardboard insert for rigidity. Artwork may be inserted and displayed on both sides. *5 sizes*

<i>Item #</i>	<i>Description</i>
<b>5010AW</b>	18" x 24" Print Holder
<b>5010BW</b>	20" x 26" Print Holder
<b>5010CW</b>	26" x 32" Print Holder
<b>5010DW</b>	30" x 40" Print Holder
<b>5010EW</b>	32" x 43" Print Holder



## Print Display Rack

These rugged display bins are designed to hold up to 100 unframed prints, posters, or pieces of art. Use them in galleries, shows, and art fairs. They can display works measuring up to 32" x 40". Bins are constructed of welded, square, heavy gauge, one-inch steel tubing with powder electrostatic, scratch-resistant black paint. Locking casters provide a sturdy base for reviewing pieces on display.

<i>Item #</i>	<i>Description</i>
<b>493</b>	Print Display Rack



Items with this symbol "Ride Along" with your length or chop moulding order at no extra delivery charge.



Items with this symbol are Special Order from the U.S.

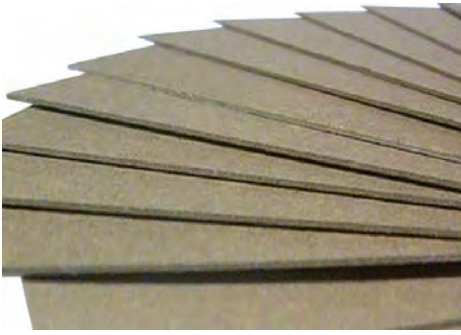

## Bainbridge Newsboard

Newsboard is the most economical mounting board there is. Suited for use with inexpensive or temporary artwork and reinforcement backings on mirrors, signage, and display work. Ideal filler for non-conservation treatments.

Item 1069E - 2-ply (.040), **60** 32.5 x 41" sheets per box  
 Item 1069F - 4-ply (.080), **30** 32.5 x 41" sheets per box

Item #	Description
1069E	2-ply Newsboard (.040)
1069F	4-ply Newsboard (.080)



## Corrugated Cardboard Sheets

Doubled walled, 200-pound test, c-fluted corrugated cardboard sheets available by the sheet or in 25-sheet sets. A must-have for packaging and protecting finished work.

Available in 5 sizes:  
 32" x 40", 36" x 48", 36" x 72", 40" x 64", & 48" x 96"

Item #	Size
CB3240	32 x 40
CB3672	36 x 72
CB4064	40 x 64
CB4896	48 x 96



## Cardboard Corner Protectors

Available in adjustable and fixed depth sizes, these sturdy 200 lb. test white cardboard corners are easy to assemble for a snug secure fit, protecting your finished projects while in storage or transit.

• Available in bulk 8,400 corner pallet! (Item 2065C)

Item #	Type/Depth (Qty/Box)
H220	Adjustable 1/2"- 1.5" (200)
H221	Adjustable 2"- 2.5" (700)
Item #	Type/Depth (Qty/Box)
H217	Adjustable 1/2"- 1.5" (1000)
H218	3/4" fixed size corner (1000)
H219	1" fixed size corner (1000)

Item #	Description
2065C	8400 ct. Bulk Pallet-Adjustable Corners  Adjustable 1/2"- 1.5" (not eligible for Ride Along program)



## Bubble Bags

Give your more delicate projects an extra amount of protection with Bubble Bags.

Item #	Description
8362	50 ct. 21x26 Bubble Bags
8364	30 ct. 26x36 Bubble Bags
8366	25 ct. 33x43 Bubble Bags



## Bubble Corner Pads

Protect frame corners with an extra layer of padding with bubble corners. **Works great in tandem with cardboard corner protectors or alone.** Also used for protecting readymade stock frames and for delicate finish frames before adding cardboard corners.  
 Small, Medium, & Large

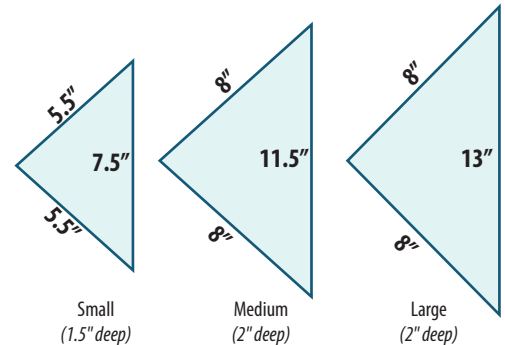

Item #	Description
8350	2250 ct. Small Corners
8352	1000 ct. Medium Corners
8354	800 ct. Large Corners



## Plastic Bags • by the Roll

Clear, 2 millimeter thick plastic bags are rolled and perforated for easy dispensing. Great for wrapping and protecting finished work in your frameshop as well as protecting delicate materials & inventory such as mat scraps, fabrics, etc. Available in 11 sizes.

Need a dispenser for your Plastic Bags?  
 See our All-in-One Dispensers on Page 46

We maintain the highest bag per roll count for the lowest price per bag!

Item #	Size	Bags/Roll
5005A	14 x 17	500
5005B	18 x 21	500
Item #	Size	Bags/Roll
H222	21 x 25	300
H223	25 x 35	180
H224	35 x 44	100
H225	36 x 48	90
H226	44 x 64	55





## Bubble Wrap • by the Roll

250' and 500' rolls of high quality bubble wrap, perforated every 12" for easy tear & wrap functionality. Available in 1.25" large bubble, and 3/8" small bubble in either 24" or 48" wide rolls.

Item #	Description
PM100	24" Large Bubble, 250'
PM102	24" Small Bubble, 500'
PM101	48" Large Bubble, 250'
PM103	48" Small Bubble, 500'



## Foam Padding • by the Roll

750' of soft lightweight 3/32" polyfoam available in 12", 24", and 36" wide rolls.

Item #	Description
PM108	12" - 750' polyfoam roll
PM107	24" - 750' polyfoam roll
PM106	36" - 750' polyfoam roll

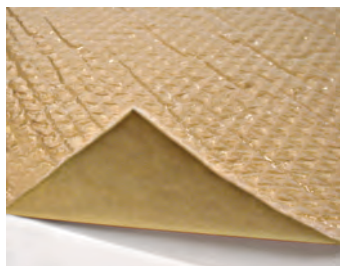

## Bubble with Kraft Backer

Convenient all-in-one kraft paper with bubble wrap padding, used to quickly make folded corner protectors for frames.  
6" x 250 ft. roll

Item #	Description
PM109	6" - 250' roll



## Stretch Wrap

80-gauge stretch film in a 16" wide roll, perfect for wrapping and binding large quantities of items when packaging for transport. Great for grouping items on pallets, consolidating boxes, and securing finished framing projects for delivery.

Hand dispensible 1,500 ft. roll

Item #	Description
PM105	16" x 1500' stretch roll



## Stretch Wrap • 5" Wand

Handy wand of 5" stretch wrap allows quick work of wrapping items for packaging. Each wand holds 1000 feet of 80-gauge stretch wrap.

Item #	Description
PM104	5" x 1000' stretch roll



## Shrink Wrap Film • Center Folded

Acid-free center-folded clear polyvinyl shrink plastic for use with manual or automated shrink wrapping machines. Will not discolor or emit harmful gasses.

75-gauge, 500 ft. rolls

Item #	Description
2110	24" 75-gauge roll, 500'
2111	28" 75-gauge roll, 500'
2112	32" 75-gauge roll, 500'
2113	36" 75-gauge roll, 500'

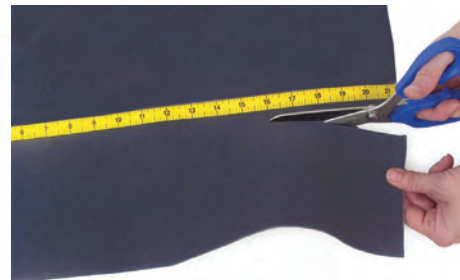

## Loop Fabric

Designed for engagement with VELCRO® type hook fasteners. Made of 100% nylon fabric that you can apply to boards, walls, and other substrates for shop displays, portfolios, etc.

Sold by the yard. Available in gray or black.

Item #	Fabric size/Description
4240	60" wide Gray loop fabric
4242	60" wide Black loop fabric
Item #	Fabric size/Description
4244	54" wide Black w/PSA Backer

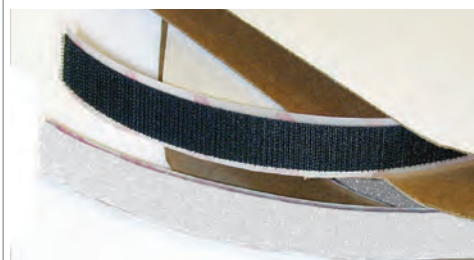

## Adhesive Hook & Loop

Velcro type hook & loop fabric backed with high-tack pressure-sensitive adhesive. 1" wide  
Available in 25 yd. rolls or by the yard (3 yard minimum).

Item #	Description	Item #	Description
4232H	Hook - Black	4230H	Hook - White
4232L	Loop - Black	4230L	Loop - White

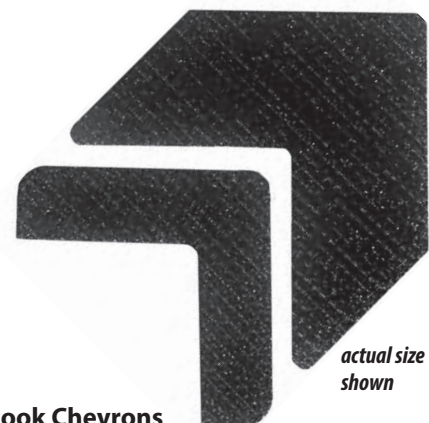

## Hook Chevrons

Self-adhesive VELCRO® type hook fasteners ideal for attaching to corner samples or signage. Made of 100% nylon fabric that you can apply to covered walls, loop fabric, etc. Strong adhesive sticks to wood and maintains adhesion for years.

Large: 3/4" x 1 3/4", Small: 3/8" x 1 3/4"

Item #	Size • Qty. Per Roll
SMCHV	Small Chevrons • 1500 per roll
LGCHV	Large Chevrons • 900 per roll



Items with this symbol "Ride Along" with your length or chop moulding order at no extra delivery charge.



Items with this symbol are Special Order from the U.S.

★ Call for current pricing



**79170**

Box Qty: 150 ft.



**79169**

Box Qty: 360 ft.

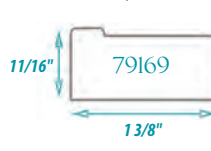

*gallery wrap stretcher*



**80382**

Box Qty: 115 ft.

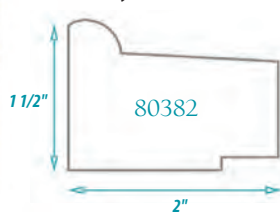

**83890**

Box Qty: 220 ft.

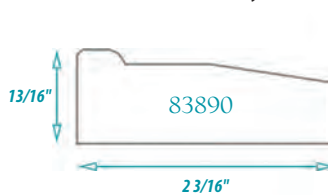

**83394**

Box Qty: 210 ft.

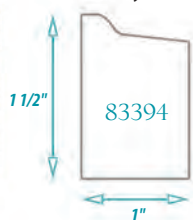

**83802**

Box Qty: 440 ft.

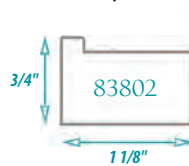

*Dual-Height Stretcher • Large*



**83395**

Box Qty: 115 ft.

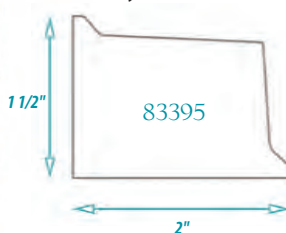

**83393**

Box Qty: 300 ft.

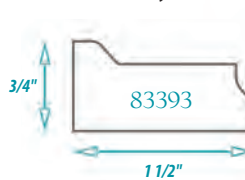

*Dual-Height Stretcher • Small*



• All stretchers are made from First Quality finger-jointed pine from sustainable sources



 All Educational Media items are Ride-Along eligible

 All Educational Media items are Special Order from the U.S.



### Picture Framing

Cutting, joining, moulding, glazing, measuring, mats, mounting equipment, frame design, working with canvas, conservation.

• **Item B116**



### Mat Cutting & Decoration

50+ mat cuts, V-grooves, French mats fabric wrapping, multi-openings, circles, ovals, gothic arches, and other specialty cuts.

• **Item B019**

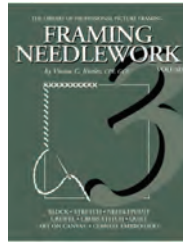

### Framing Needlework

Blocking, stretching, cleaning, crewel, needlepoint, cross-stich, antique samplers scarves, flags, and more.

• **Item B027**



### Conservation Framing

Art on paper, glazing, hinges, adhesives, boards, encapsulation, deacidification, framing fine art & heirlooms.

• **Item B035**

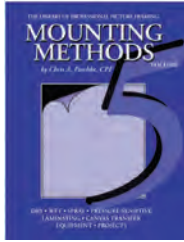

### Mounting Methods

Drymounting, wet mounting, spray adhesives, boards, equipment, laminating, canvas transfer.

• **Item B043**



### Framing Photography

Mounting & framing multiple types of photographic media, finishes, & papers. Creative projects involving portraiture.

• **Item B051**

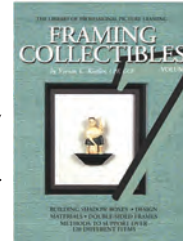

### Framing Collectibles

Building shadow-boxes, double-sided frames, hinged boxes, and other creative projects for 3-dimensional objects and keepsakes.

• **Item B299**



### Cutting, Carving & Decorating Mats

How-to's on multi-angles, V-grooves, inlays, color panels, and unique mat carving techniques. Author Brian Wolf's favorite tips & tricks included with traceable patterns.

• **Item B85X**

## Where is Mrs. Smith's Watercolor?

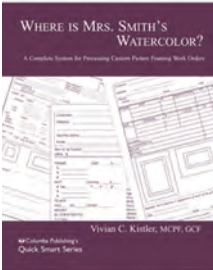

Have you ever had to search for a customer's framed piece? Avoid this unprofessional and embarrassing moment. This book will help you understand and establish a process for your framing jobs that will not only help your shop be more productive, but will reflect the professionalism that your customers expect. The efficient workflow of a frame shop is essential to success.

• **Item B06X \$15.00**



## Who's the Boss?

Get the answers to common problems with employment. How to set up a training program for framers, frame counter salespeople and gallery salespeople. Setting the standards and company policy regarding: image of the company, framing methods, safety practices, operating equipment, waste, attitudes, product knowledge, selling procedures and customer complaints.

• **Item B221**

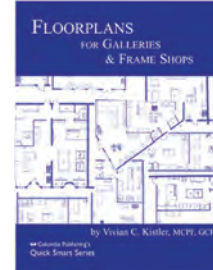

## Floorplans for Galleries & Frame Shops

Nineteen floorplans for working shops are illustrated in this book. The assortment of shops includes galleries, frame shops, frame shops with galleries and galleries that offer framing. Included are illustrations of worktables and storage units for art, moulding, matboards, and supplies. Grid enclosed to begin your own shop layout.

• **Item B272**

## Starting a Picture Framing Business

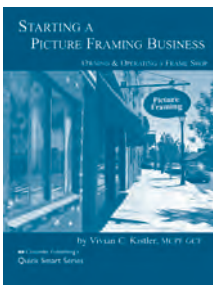

Valuable advice and insight on entering the marketplace. Topics include: Types of Shops, & Ways to Start a Frame Shop. Business Matters includes Business Entity, Lawyers, CPA, Bankers, Bookkeeping & Accounting, Financial Statements, Purchasing, Business Plan, and start up costs. Tips for choosing shop locations, hiring employees, and much, much more.

• **Item VK760**

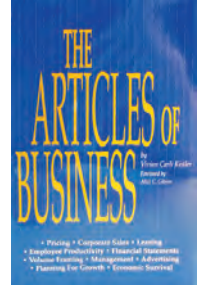

## The Articles Of Business

Advice from a leading expert in the industry. 17 chapters include: Start up Credit terms. Finance. Leasing. Volume Framing. Pricing the Custom Product. Advertising. Corporate Sales. 100 Answers to Expert Questions include: Location, Merchandising, Personnel, Production, Quality Control, Management, Advertising. Just getting started?--you'll need this book!

• **Item B280**

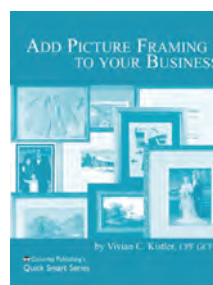

## Add Picture Framing To Your Business

Framing can complement many art and design-oriented businesses. There are many levels of picture framing service from simple ready-made frames to complete custom framing. This book explains the five methods of offering this service as well as how the business of framing operates. Basic techniques, equipment, space requirements, pricing and a processing system are explained.

• **Item B477**



## Decorative Accessories Made From Moulding

Ever wonder what to do with all those pieces of scrap moulding? Learn how to transform them into imaginative creations! What to make, how to measure, cutting, building, lining, finishing tips. Step-by-step instructions.

• **Item B604 \$16.00**

## Event Planning & Marketing for Frame Shops

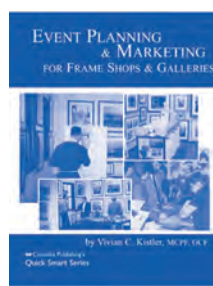

No shop is too small to hold an event! Traditional gallery show, charity benefit, or celebration of your years in business: whatever the occasion, an event in your shop creates excitement and gives you a great opportunity to attract customers and make sales. This book guides you through the entire process from advertising to running the event, to building relationship.

• **Item B574**



## Selling At the Framing Counter

Custom Picture Framing is a true Service Industry-one of very few available today to the average person. Selling picture framing requires a level of helpfulness and knowledge rarely seen in today's marketplace, and a one-of-a-kind product. Specialty retail shops survive because they offer something different from mass market stores. It is not just providing a product, it is a relationship.

• **Item B-353**

 Educational Media items "Ride Along" with your length or chop moulding order at no extra delivery charge.



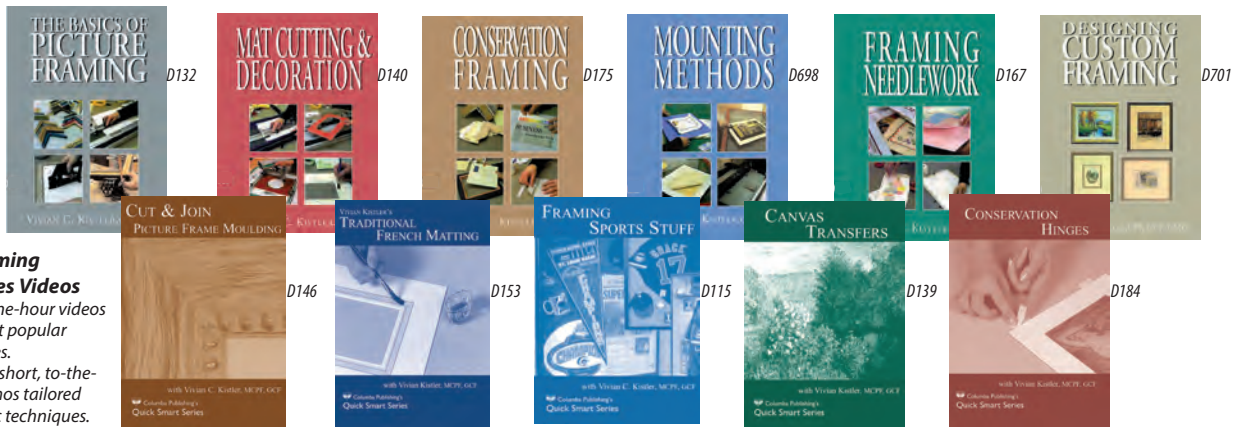

**Vivian Kistler's Framing & Quick Smart Series Videos**  
Instructional framing one-hour videos demonstrating the most popular methods and techniques. Quick Smart videos are short, to-the-point 15-30 minute demos tailored toward learning specific techniques.

• Framing Instruction Videos

- Item #**    **Download:**
- D132** Basics of Picture Framing
  - D140** Mat Cutting & Decoration
  - D175** Conservation Framing
  - D698** Mounting Methods
  - D167** Framing Needlework
  - D701** Designing Custom Framing

• Quick Smart Series Videos

- Item #**    **Download:**
- D146** Cut & Join Moulding
  - D153** Traditional French Matting
  - D115** Framing Sports Collectibles
  - D139** Canvas Transfers
  - D184** Conservation Hinges

**Measuring Made Easy**

Tackles the basics of how to measure for creating picture framing projects.

• **Item D981**

**Cutting & Installing Fillets**

How to measure & cut fillets to properly fit into your cut mats.

• **Item D566**



**Achieve Professional Results with a Master Class in Digital Printing**

The Perfect Print is a professional level workshop series of 5 DVDs by master printer Randy Hufford (M. Photography, CR, PPA Certified). From Photoshop techniques that will get your images to stand out, including finishing, stretching, framing, and selling. These methods will showcase your work as a true piece of art, as well as give you the edge when outputting prints for your customers.

**Calibration**

This DVD makes Soft Proofing easy to understand with simple steps you can follow to maximize your workflow production. Soft Proofing is the system used to see on the computer monitor what the actual print will look like before printing.

• **Item D101**

**Ink & Media**

In this DVD you will be given insight into which medias you should use based on your application. Packed with valuable information about a variety of medias, inks, ICC printer profiles, an overview of printer technologies, advantages of a software RIP, and much much more.

• **Item D102**

**Digital Art Enhancements**

Learn how to get your images prepared and looking their best before you print them. You will be shown simple techniques in both Photoshop and Lightroom, which will make the output from your customers digital files better than you have ever seen before.

• **Item D103**

**Finishing Techniques**

In this DVD, you will be introduced to different finishing techniques for working with Canvas and Fine Art Medias, from coating your prints to embellishing them and to increase your profits by providing properly finished & beautiful works of art.

• **Item D104**

**Marketing Giclée**

Randy shares his experiences and insights on how to succeed with good marketing and increase your exposure and sales of Fine Art Prints and Digital Printing services. Who can benefit from these techniques? Anyone in the Art and Framing industry!

• **Item D105**

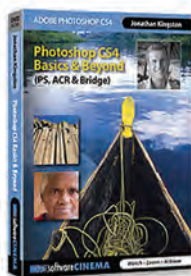

**Photoshop CS4 Basics & Beyond**

Learn Photoshop CS4 from the ground up with a professional photographer's perspective. Perfect for beginners to pros who need an in-depth knowledge of CS4. Learn methods for taking your photographs from processing to printing with control and predictability using Photoshop.

Instructed by Jonathan Kingston  
• **Item D106**



**Solutions for Photographing Artwork**

Correctly reproducing the exact color and texture of a painting in a photograph has always been a challenge. Ideal for artists, framers, gallery owners, this essential collection of tutorials teaches photographers how to accurately photograph 2 dimensional artwork for replication.

• DVD ROM  
• **Item D100**



**Tensador II Canvas Stretching Machines** 

Tensador II is a pneumatic machine designed to stretch canvas using a unique clamping mechanism. It firmly grips canvas without piercing or tearing and assures proper tension without ripples or over stretching. Comes with foot operated adjustable safety pedal, air filter, and air regulator and requires no electricity. Tensador II can be used with dedicated silent air compressors or shop dedicated air lines. Stretches canvas from 8" x 8" through 48" x 48" (T-125) or 60" x 60" (T-155).

The unique gallery wrap on the Tensador II provides access to the back side of the stretcher bar. This operation requires use of a long nose staple gun (see pages 25-26) to reach the back side of the bar. Gallery wrap or stapling on the back side of the stretcher requires 1 1/2" for canvas past the back side of the stretcher bar to staple on the side 3/8" is required. Each model can accommodate most any commercial stretcher bar size from 1/2" - 2 1/2" thick. The canvas image area is visible during stretching operation to ensure proper location of image.

Necessary adjustments can be made for canvas size changes resulting in fast production when stretching multiple size images or bar sizes. The machines small footprint makes for easy storage or permanent placement within your frame shop or production house. Can stretch up to 20-30 canvases per hour.

Item #	Description
4137	T-125 48" Tensador II Canvas Stretcher & Gallery Wrap Machine
4137A	T-155 60" Tensador II Canvas Stretcher & Gallery Wrap Machine



**C+H Thumbnail Master** 

The C+H Thumbnail Master is the industry's leader in thumbnail routers, lending versatility in frame joinery for small and large framing businesses alike. The Thumbnail Master provides routing of thumbnail channels at 6 depth capabilities, all easily set on an easy-to-read dial. Allows thumbnailing mouldings up to 1 7/8" deep and has a versatile clamping height which can hold mouldings from 1/2" to 3 3/4" tall. Easy grip guide handle and ratcheted bit handle for simple adjustment of the routing bit.

For Thumbnail inserts, see Page 22

Item #	Description
5050B	C+H Thumbnail Master



**Router Bits for C+H Thumbnailer** 

Steel and carbide replacement bits for the C+H Thumbnail Master router. 

Item #	Description
5054	Steel Replacement Bit
5054C	Carbide Replacement Bit



**EXP42 Plus Laminator** 

The EXP 42 Plus Laminator is a heavy duty, industrial strength wide format laminating machine. It features variable speed, heated rollers, and can be mounted on a stand (optional) or table. Mounts and laminates printed material in a few simple steps, and is very easy to maintain. A perfect fit for galleries, frame shops, and digital print shops.

- Working Width: 41"
- Width: 57"
- Height: 19 1/4"
- Depth (with feed tray): 27 1/2"
- Net Weight (Minus Stand): 205 lbs.
- Shipping Weight: 420 lbs.
- Speed: 0 - 10 fpm
- Maximum Temperature: 300°F
- Maximum Aperture: 1/2"
- Roller Diameter: 3"
- Electrical Requirements: 230V 30A
- Footswitch: (optional)
- Release Liner Rewind: (optional)
- Slitter Kit: (optional)

Item #	Description
6190	42" EXP Plus Laminator



**Traco 40" Shrink Wrap Machine** 

The Traco SS-40DS Deluxe SuperSealer Shrink Wrap System is perfect for any project that needs sealing. Portable, lightweight and sleek, the Deluxe SuperSealer is built to last. The SuperSealer cuts and seals film automatically, no need to tear your package away. It uses any type or gauge of film. Comes with an adjustable LED timer, maintenance kit and a lightweight adjustable temperature heat gun. No assembly required, just plug in and start packaging. Kit includes starter roll of film.

• Uses Item#s 2110-2113, Shrink films on Page 49

Item #	Description
9200	Traco 40" Shrink Wrapper





### Drytac Hot/Cold Vacuum Press

Ranging from photographs, to delicate graphics, digital prints, and posters, as well as for mounting overlay laminates, canvas transfers, and fabric mats, this vacuum press is a well proven, highly technological product that features a clear tempered glass top that contain heating elements. The glass surface distributes heat evenly to provide a stable mounting temperature and allows the user to view the mounting process to avoid mistakes. The glass top platen quickly reaches the desired temperature and maintains an accurate temperature within 5 degrees (depending on opening and closing). Unit features digital controls, programmable heat & time settings, LCD readouts, manual override switch, and a resettable circuit breaker. Comes complete with 110 volt vacuum pump. Requires 220 volt hook up (plug included). Made in the USA.



Item #	Description	Each
1401	36" x 48" Drytac Glass Top Vacuum Hot/Cold Press	\$ Call for Pricing
1400	44" x 68" Drytac Glass Top Vacuum Hot/Cold Press	\$ Call for Pricing

Item #	Description	Each
1408	Floor Stand for 36" x 48" Drytac Press	\$ Call for Pricing
1409	Floor Stand for 44" x 68" Drytac Press	\$ Call for Pricing



### D&K Hot/Cold Vacuum Press

The D&K® Hot/Cold Vacuum Press is the preferred choice among professionals for dry mounting and laminating photos, artwork and posters. Microprocessor technology and touch-pad controls assure efficient, easy and reliable operation. Two available models range in working capacities of 44"x 68" (4468H), and 48" x 96" (5298H). Features a programmable systems controller that allows the user to select from six factory set programs, or easily preset your own combination. Features a maintenance-free vacuum pump, Dura-Box alloy frame with tight vacuum seal, end-of-cycle signal, and easy to read digital display. Unique bladder system permits mounting of materials of different thicknesses in a single cycle. Excellent for hot or cold, wet or dry mounting, laminating, applying textures, etc. Floor stand sold separately. 230 volt power required. Made in the USA.



Item #	Description	Each
4468H	44" x 68" Hot/Cold Vacuum Press	\$ Call for Pricing
5298H	48" x 96" Hot/Cold Vacuum Press	\$ Call for Pricing

Item #	Description	Each
4468STND	Floor Stand for 44" x 68" Vacuum Press	\$ Call for Pricing

### D&K 550 Heat Mount Press

The D&K® 550 mechanical heat mount press is the versatile and dependable choice of framing professionals for the creative mounting and laminating of photos, artwork and posters, among other materials. This is the original soft-bed dry mounting/laminating press with adjustable 150-300 degree temperature control. Working area is 26 x 34 inches and press can complete larger jobs by working one area at a time. Pressure adjusts to fit materials up to 1" thick. The D&K 550, was previously known as Bienfang 550 & Seal model 500T-X. Includes built-in electronic temperature control with digital display and touchpad controls. Six pre-set programs for efficient operation, or set your own desired time & temperature. Operates on 120 volts. Made in the USA.



Item #	Description	Each
550	D&K 550 Mechanical Heat Press	\$ Call for Pricing

 Items with this symbol are Special Order from the U.S.



Items with this symbol "Ride Along" with your length or chop moulding order at no extra delivery charge.





## IM-30 Rotating Miter Saws

### IM-30 PLUS

The IM-30 family of economical saws come pre-assembled from the factory. Designed to meet your needs for cutting wood, plastic and aluminum profiles with precision quality and productivity with the proper blade, the IM-30 can be designed with the options you require. Easy movement from +45° to the -45° by using the quick rotation handle of the saw head, it is possible to turn off the Lubricant Sprayer when cutting wood and plastic profiles. Cuts to 4" wide x 2 7/8" high. The IM-30 saws have a cast aluminum structure. The blade is on the axle of the motor improving rigidity for an accurate cut.



Model IM-30 Plus

### Information & Features of the IM-30 PLUS

- Includes right and left calibrated scale, cabinet base with incorporated and independent dust collector unit, moulding stop to allow repetition of cuts sizes, pneumatic clamping system, lubricant fluid sprayer.
- Pneumatic clamping system to secure the profile to be cut, improving safety to operator. Air source required as this feature is operated pneumatically.
- Pneumatic lubricant fluid sprayer to lubricate and cool the metal and the blade while making the cuts, offering perfect finishing and greater durability to the blade.
- Please note: For optimum performance this machine is wired for 220v. You can have an electrician reconfigure it to be 110v.
- Self-locking device with heavy-duty conical pin with precision lock positions for the most used angles 0°, 10°, 15°, 22.5°, 30°, 45°.
- Quick adjust rotation feature, for easy movement of the blade.
- Calibrated scale to make accurate measurements to 47" long.
- Powder coated paint provides for a durable finish for the life of the saw.
- Please note that the blade is not included with this equipment; choose the proper blade for each type of material.

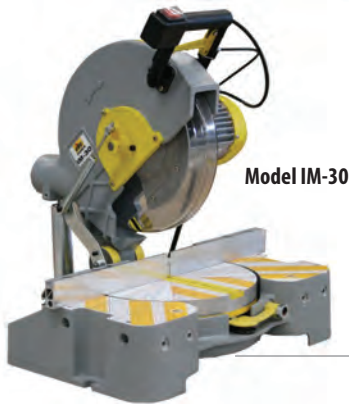

Model IM-30

### IM-30 Models Available:

*Please note: For optimum performance the following IM-30 models are wired for 220v. You can have an electrician reconfigure it to be 110v.*

**IM-30** – Basic single miter saw without blade.

**IM-30MP** – Includes cabinet base with incorporated dust collector, right and left table extension with calibrated scale, sliding moulding stop, and automatic clamping system to hold moulding in place when cutting.

**IM30PLUS** – Includes cabinet base with incorporated dust collector, right and left table extension with calibrated scale, sliding moulding stop, automatic clamping system to hold moulding in place when cutting, plus pneumatic lubricator for cutting aluminum.

**IM-30AL** – (*Special Order*) Includes cabinet (without dust collector), right and left measuring scale, sliding moulding stop, and fluid lubricant sprayer to cut aluminum moulding.

### Miter Disc Sander

With this tool, you can accurately true a corner by simply rotating the 12" sanding disc against the miter cut. This allows for perfect corners when joining and therefore aids in producing a quality frame every time. Comes with a 45 degree template for accurate setting, Allen wrenches, a cleaning stick, and 3 sanding disks. *Attaches easily to strong level work table.*

Item #	Description
6585	Miter Disc Sander



### 3M Miter Sanding Discs

This 12-Inch diameter 100 grit aluminum oxide sanding disc is sized to fit most common disc sanders and is sold in a 3 pack. This sanding disc is pre-applied with pressure sensitive adhesive.

Item #	Description
6585R	Replacement Sanding Discs

**For Pricing & Information on miter saws & equipment, call Omega today at 1-877-452-3799**

 Items with this symbol are Special Order from the U.S.



## IM-300 Double Miter Saws

### IM-300P Double Miter Saw • For Mouldings up to 3 3/16" wide

The IM-300 family of double miter saws have been developed by Inmes for cutting with absolute precision giving a perfect square corner joint. By choosing the proper blade and accessories the operator may cut raw, finished wood, plastic and aluminum. The IM-300P cuts miters with maximum dimensions of 3-3/16" wide by 3-3/16" height, with simultaneous action of the blades, which enables high production. Ships complete with blades, measuring scales, and built-in dust collector.

#### Information & Features of the IM-300P

- 2 - 1 1/2 hp. 220 volt single phase 3400 rpm induction motors (three phase available).
- The IM-300 P can be equipped with a wide range of accessories on demand.
- Uses 12" blades, 1" bore for cutting. 1 set (2 blades) is included.
- Front access through panel, making it quick to change the blades.
- Safety switch on front panel. Blades will not operate if open.
- Simultaneous action of the blades through a pneumatic foot pedal.
- Ample view of internal work area with illumination.
- Adjustable speed of blades descent.
- Pivot mechanism with conical bearings on cutting arms for greater precision and durability.
- Right Side Calibrated scale 58" long included. Optional 58" left side calibrated scale and 39" additional right scale also available.
- Moulding stop for setting lengths of cuts and repetitive cuts.
- High powered Dust collector with 3/4 hp 220 volt single phase motor and exhaust filter.
- Powder coated paint for a long lasting durable finish.
- Weight 616 lbs.
- Shipping dimensions 31" x 51" x 59" tall.

- **Item# 300PL39R** · Additional 39" Right Extension
- **Item# 300PL58L** · Additional 58" Left Extension



Model IM-300P

### IM-300PL Double Miter Saw • For Mouldings up to 5 5/8" wide

The IM-300PL double miter saw was developed by Inmes to meet the growing demand of equipment and provide best quality cuts on several kinds of material. By choosing the proper blade you may cut raw, finished wood, plastic and aluminum profiles. The IM-300PL is a very robust machine making it possible to obtain high quality cuts. In one single piece of equipment you can get Quality, Safety, Design, and the best-cost benefit/ratio. Table height: 35.4", Bse: 48" x 26". Weight: 495 lbs.

The IM-300PL has the features of the above IM-300P but is capable of cutting up to 5 5/8" wide by 3 3/16 tall moulding. The blades operate in sequence, individually moving one at a time to allow this extra capacity. Pneumatic hold downs included to secure moulding for better cut quality and operator safety. Requires compressed air. Shipping weight: 730 lbs.



Model IM-300PL



#### Sprayway Saw Cleaner

Spray to quickly clean away pitch and gum from saws, router bits, and shape cutters. Safe to use on carbide, high speed steel, stainless steel, and cast iron surfaces. Works in just minutes! 18 oz. can

Item # Description  
**SP836** Sprayway 836 Saw Cleaner



#### ProVizGard Safety Glasses

Polycarbonate temples and single-piece wrap-around lens provide superior protection. Special lens coating for superior scratch resistance. Adjustable temples for a safe and perfect fit. ANSI Z87.1-2003 standard certified

Item # Description  
**SGP43MB** ProVizGard Safety Glasses

For Pricing & Information on miter saws & equipment, call Omega today at 1-877-452-3799

 Items with this symbol are Special Order from the U.S.



Model IM-350P



Equipped with right & left arm  
(Optional right arm extension available)



Model IM-350M

## IM-350P Double Miter Saw • For Mouldings up to 8" wide

The IM-350P has been developed by Inmes for cutting with absolute precision to give a perfect square corner join for picture, photo framing and woodworking applications such as windows, doors and furniture components. By choosing the proper blade the operator may cut raw, finished wood and plastic moulding profiles. The large cutting capacity enables miter cuts up to 210mm (8") in width by 100mm (4") in height. The two saw blades are fixed at 45-degree angles and the blades are moved independently by a pneumatic control system.

### Information & Features of the IM-350P

- Included with the equipment is a 14" set of saw blades for cutting.
- 2 HP high resistance induction motors 220 volt single phase.
- Access through the front panel makes for a safe, easy change of the saw blades. A safety switch prevents blade rotation.
- Heavy duty pivot mechanism with bearings on cutting arms.
- Calibrated 50" arms for each side (right and left) are included. An optional 39" right arm extension is available.
- Moulding stop for accurate setting of the length of cuts.
- Powder-coated paint provides a durable finish for the life of the equipment.
- The IM-350P comes with a drawer located inside that holds dust and waste materials. You may order the IM-350P with an optional chute that discharges the dust and waste materials out of the rear of machine.
- During the cutting process the moulding cannot move as it is firmly held to the work table by a horizontal clamping system that is activated by manually pulling handles forward.
- Adjustable speed of blades descent.
- Requires compressed air fitted with filter lube regulator.
- Unit dimensions with right 50" scale 59" x 33" x 108" wide
- Shipping weight 932 lbs.

## IM-350M Double Miter Saw • Manual version of IM-350P

The IM-350M Double miter saw was developed with most of the features of the IM-350P. The main difference is that the 2 - 14" carbide blades are moved horizontally and independently by a manual control system. It offers miters with 8" wide by 4" height, with independent action of the blades.

- Vertical clamps to secure the profile in place during cutting.
- Right and Left calibrated 50" scale.

**For Pricing & Information on miter saws, call Omega today at 1-877-452-3799**



## Inmes Saw Blades • With Nano-Grain Carbide tips that stay sharper longer!

**SBHW96T** • (for IM30) 12" 96-tooth, 30mm Bore (Wood only) saw blade with Nano-Grain Carbide teeth configured with an alternate bevel. Designed for superior cutting on hardwood mouldings.

**SBWG90T** • (for IM300P/PL) 12" 90-tooth, 25mm Bore (Wood & Gesso) saw blade with Nano-Grain Carbide teeth configured with a 4:1 alternate bevel. Designed for superior cutting on wood and gesso mouldings.

**SBWD100T** • (for IM350M/P) 14" 100-tooth, 30mm Bore (Wood only) saw blade with Nano-Grain Carbide teeth configured with a 4:1 alternate bevel. Designed for superior cutting on wood mouldings. Great for gesso coated profiles.

**SB120CT** • (for IM30) 12" 120-tooth, 30mm Bore carbide saw blade with alternate bevel teeth specially designed for cutting aluminum and non-ferrous metal mouldings with wall thickness up to 3mm.

 Items with this symbol are Special Order from the U.S.





**Dust Collectors**

- Designed to collect dust from small, medium and large machines.
- Filters are capable of permeability of 150 liters/min. dm<sup>2</sup> to 20 mm ca.
- Metal impellers and a powder-coated paint finish make for extreme durability.
- Low noise operation between 77 and 85 dB.
- Swivel castors enable total mobility.



**EM-75A Dust Collector**

Item# DC75A

- 530 c.f.m.
- 110-120 volt single phase
- 16.4" main feed cable – no plug
- 4" input diameter
- 16"d x 35"w x 23"h
- Weight 53 lbs., ship weight 64 lbs.



**EM-100A Dust Collector**

Item# DC100A

- 706 c.f.m.
- 110-120 volt single phase
- 5.9" main feed cable – no plug
- 4" input diameter
- 18"d x 32"w x 40"h
- Weight 75 lbs., ship weight 84 lbs.



**EM-200A/S Dust Collector**

Item# DC200A

- 1200 c.f.m.
- 220 volt single phase, 60 Hz
- 4" input diameter
- 20"d x 37"w x 67"h
- Weight 108 lbs., ship weight 129 lbs.



**EM-300A2 Dust Collector**

Item# DC300A2

- 2295 c.f.m.
- 220 volt, 3 phase 60 Hz
- 3 inlets of 4" each
- 27"d x 58"w x 76"h
- Weight 168 lbs., ship weight 206 lbs.



**Underpinners**

- Features exclusive clamp height adjustment
- Uses v-nails in color coded cartridges for soft or hard wood
- Include heavy duty drive hammers

- Foot pedal height adjustment (manual models)
- Powdered coated paint provides a durable finish
- Simple adjustment for the proper positioning of v-nails
- Easy insertion of v-nails, which are stackable



Model UP2-SE



Model UP3-SE



Model UP3-PSE

**Underpinner • UP2-SE**

The UP2-SE is a quality entry level underpinner and is designed for joining wood and plastic frames in low volume shops and the hobby trade. Production capacity is approximately 400 frames per 8 hour shift. It does not require electricity or air source as the wedge is inserted by a heavy duty mechanical gear that is foot activated. Height adjustable foot pedal and vertical clamp height adjustment. Hard or soft v-nails can be used and can easily be stacked for shadowbox frames, etc. Powder coated finish for durability.

Item #	Description
UP2SE	Inmes Underpinner

**Underpinner • UP3-SE**

The UP3-SE underpinner has been specially designed for joining wood and plastic frames and is well suited for low and medium production frame shops and the semi-professional hobby trade. Production capacity is approximately 800 frames per 8 hour shift. Like the UP2-SE model, it does not require electricity or air source as the wedge is inserted by a heavy duty mechanical gear that is foot activated. Height adjustable foot pedal and vertical clamp height adjustment. Hard or soft v-nails can be used and can easily be stacked for shadowbox frames, etc. Powder coated finish for durability. Extension table available (see bottom of page).

Item #	Description
UP3SE	Inmes Underpinner

**Underpinner • UP3-PSE**

The UP3-PSE is a pneumatic underpinner specifically designed for joining wood and plastic frames. This machine is well suited for medium and high production shops and the semi-professional hobby trade. Production capacity is approximately 1,000 frames per 8 hour shift. Compressed air is required for operation. Foot pedal administered air pressure. Exclusive vertical clamp height adjustment. Hard or soft v-nails can be used and can easily be stacked for shadowbox frames, etc. Powder coated finish. Extension table available (see bottom of page).

Item #	Description
UP3PSE	Inmes Pneumatic Underpinner

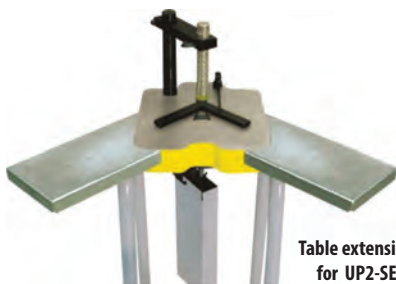

Table extension for UP2-SE



Table extension for UP3-SE and UP3-PSE

**Table Extensions for UP2-SE, UP3-SE & UP3-PSE**

These handy table extensions increases the work area on the joining plane of the UP2-SE, and UP3-SE & PSE, making it easier for supporting medium to large mouldings while underpinning. Angled platform allows for adding larger supports if desired. Easy to attach with standard tools.

Item #	Description
2PTBL	Table Extension for UP2-SE
3PTBL	Table Extension for UP3-SE & UP3-PSE

Items with this symbol are Special Order from the U.S.



**UP4-P & UP5-PH  
Pneumatic Underpinners**

- Features exclusive clamp height adjustment
- Comes complete with heavy duty tilting floor stand.
- Exclusive system for quick change of the v-nail size. Just turn the rotary knob allowing the use of v-nails in 5, 7, 10, 12, and 15mm heights.
- Include main air regulator, water separator, and system oiler.
- Top clamp is always exactly over the v-nails insertion point.
- Production capacity of 1000-1500+ frames per 8 hour shift.
- Offer a vertical and horizontal clamping system, enabling a quality join.
- Use hard wood or soft wood v-nails. No cartridge needed.
- The v-nail can be inserted in several positions once the main head set is adjusted.
- Stacks 2-3 nails one on top of the other.
- Powdered coated paint provides a long-lasting durable finish.
- Large machine leveling screws included.



Model UP4-P

**Model UP4-P**

Joins moulding up to 5" wide. Included with this model are 3 top-clamp pads. Fitted with new finger-adjust top pressure pad system. Additional accessories are available.

Item# **UP4P**

Extension wings for UP4-P • Item# **4PTBL**

Small Table for UP4-P • Item# **4PSTBL**



Model UP4-P, top view



Model UP5-PH, top clamp system detail



Model UP5-PH

**Model UP5-PH**

Easy handling with pneumatic activation, offering precision joining with high productivity. Offers double adjustable clamps (hydraulic or mechanical) and front clamp, providing quality joining Joins moulding up to 6" wide. The v-nails can be inserted in several positions, as the solid steel hammer block is moved from one position to the next while the moulding and fence remain clamped and locked in one position. Now fitted with new finger adjust hydraulically linked adjustable twin pressure head, each with a soft-faced pressure pad.

Item# **UP5PH**

Small extension table • Item# **5PSTBL**



Model UP5-PH, top view

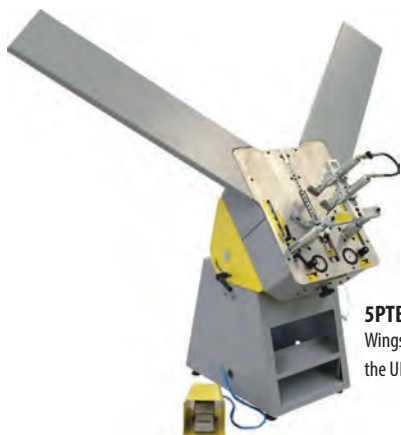

**5PTBL**  
Wings extension shown on the UP5-PH (not included)

**Wings Extension for UP5-PH**

These support wings are an option for the UP5-PH underpinner. They are 33" in length and 9 1/4" wide, extending the table size to help to support larger frame sections and the widest of mouldings. Easily attaches to joining plane.

2 wings • Item# **5PTBL**

Items with this symbol are Special Order from the U.S.





**CM50D Air Compressor** 

The CM-50D air compressor is also virtually "noiseless" and fully automatic. Equipped with line pressure gauge, pressure regulator and moisture trap. *Specifications:* 110V/60hz 1/2 HP motor, 2.25 gallon storage tank, CFM 2.15 free air, operating Pressure 84 to 114 PSI. The 50-24 compressor can manage the requirements of most small picture frame or digital art businesses. 2.25 gallon tank, small size (15.5" x 15.5" floor space) shipping weight 70 pounds. • **Item# COMCM50D**

Item #	Description
COMCM50D	CM50D Air Compressor



**CM50 Air Compressor** 

The CM50 Silent Air Compressor is virtually "noiseless" and fully automatic. Line pressure gauge, pressure regulator and moisture trap. *Specifications:* 110V/60hz 1/2 HP motor, 6.0 gallon storage tank, CFM 2.15 free air, operating Pressure 85 to 115 PSI. The CM50 compressor can manage the requirements of most small picture frame or digital art businesses. 6 gallon tank, small size (15.5" x 15.5" floor space) shipping weight 70 pounds. • **Item# COMCM50**

Item #	Description
COMCM50	CM50 Air Compressor



**CM99 Air Compressor** 

The CM99 Air Compressor is ideal for workshops with up to two underpinners operating simultaneously or over a long period of time daily. Each machine has 1 HP delivered from two motors with 4.35 CFM Free Air. Wheels are attached for ease of movement. • **Item# COMCM99**

- Air Pressure = up to 120 psi (8 bar)
- Pressure cycle = 85-115 PSI
- Shipping weight = 101 lbs
- Delivers 100 liters / minute

Item #	Description
COMCM99	CM99 Air Compressor



**Morso Miter Choppers**



**Morso-F Foot Chopper**

- Foot operated-no need for a compressor or electricity
- Cut waste drops into a waste chute
- Cutting creates no dust
- 5-year warranty

**Morso-F** 

This foot-operated chopper cuts double miters of 45 degrees, with a maximum cutting width of 4" and max. cutting height of 5¾". Comes equipped with safety guard, waste chute, sliding longitudinal stop, 59" measuring scale, adjustable fences (45-90°), and adjustable rabbit supports.

Item #	Description
MORSOF	Morso F Foot Miter Chopper



**Morso-H Semi-Automatic Pneumatic Chopper**

- As fast as a double-miter saw
- Cut waste drops into a waste chute
- Cutting creates no dust
- Noise level is below 62 dB

**Morso-H** 

Morso-H is a semi-automatic, pneumatic mitring machine with a two-hand release built on. This makes the machine absolutely safe to operate as it is impossible to start the machine and touch the knives at the same time. Max. cutting width: 4", max. cutting height: 5¾". The Morso-H is delivered with: Two-hand release operation, safety guard, sliding longitudinal stop, waste chute, measuring scale up to 59", adjustable fences (45°-90°), and adjustable rabbit supports.

Item #	Description
MORSOH	Morso-H Miter Chopper

 Items with this symbol are Special Order from the U.S.



## Morso Miter Choppers



**Morso-EHS  
Electric/Hydraulic  
Chopper**

- As fast as a double-miter saw
- Cut waste drops into a waste chute
- Cutting creates no dust
- Noise level is below 62 dB

### Morso-EHS

The Morso EH is now available in a "noiseless" version, the **Morso EHS**. The motor has been removed from the machine and is housed in a separate box. The Morso-EHS noiseless miter chopper is a fully automatic, electric/hydraulic machine with a two-hand release built on. This makes the machine absolutely safe to operate as it is impossible to start the machine and touch the knives at the same time. Max. cutting width: 4", max. cutting height: 7". Delivered with: Two-hand release operation, safety guard, sliding longitudinal stop, second stop, waste chute, extension table for the left side, measuring scale up to 59", adjustable fences, 45°-90°, adjustable and automatic rabbet supports and clamping cylinders.

Item #	Description
<b>MORSOEHS</b>	Morso EHS Miter Chopper

Morso EH, EHT, EHL, & EHD are available as "noiseless"



**Morso-EH  
Electric/Hydraulic  
Chopper**

- As fast as a double-miter saw
- Cut waste drops into a waste chute
- Cutting creates no dust
- Noise level is below 70 dB

### Morso-EH and Morso EHT Turbo

The Morso-EH is a fully automatic, electric/hydraulic mitring machine with a two-hand release built on. This makes the machine absolutely safe to operate as it is impossible to start the machine and touch the knives at the same time. Max. cutting width: 4". Maximum cutting height: 7". The Morso-EH is delivered with two-hand release operation, safety guard, sliding longitudinal stop, second stop, waste chute, extension table for the left side, measuring scale up to 59", adjustable fences (45-90°), adjustable and automatic rabbet supports and clamping cylinders. The **Morso-EHT Turbo** is the same machine as the Morso-EH, but the work cycle is 50 percent quicker.

Item #	Description
<b>MORSOEH</b>	Morso EH Miter Chopper
<b>MORSOEHT</b>	Morso EHT Miter Chopper



### Morso Chopper Blades

The tool steel used for the cutting edge on the Morso blade is formulated of Austrian steel with a Rockwell hardness of 64. The cutting edge is attached to the tool's body and then carefully heat tempered. The knife is then precision surface ground to thickness, hollow ground with the grinding wheel between 8" and 10" diameter at 30° to the face of the knife, then hand-honed and deburred. No other blade on the market can offer the precision and longevity of a Morso blade. There are no generic blades made to the same Rockwell hardness, and in many cases, they are not hollow ground or hand honed.

Item #	Description
<b>2553</b>	Standard Morso Knives Fits F, H, & EH/EHT/EHS choppers

### Rabbet Support System

This automatic rabbet support system is ideal for production work, i.e. jobs that have repetitive cuts. Automatically reset the rabbet support to the adjusted width and height of the moulding after each cycle. Saves time on manual adjustments. Includes easy-to-follow fitting instructions. For installation on Morso-F and Morso-H choppers; The automatic rabbet support system is standard on all electric machines.

Item #	Description
<b>MORSORS</b>	Automatic Rabbet Support System Fits Morso F & H choppers



### Morso Fillet Cutter

Cuts small wooden and plastic fillets of 1" x 3/4" exactly in 45 degrees. A light, very portable machine that can be placed around the shop, weighing only 21 lbs.

Knives are genuine Morso knives that can be resharpened when needed.

Item #	Description
<b>MORSOB</b>	Morso B Bench Miter Chopper



Cutting Machines



User-Friendly Software Tools:



VALIANI

Mat Pro Ultra

## The Right Machine for Your Operation.

Is it time to retire your old Computerized Mat Cutter?

- Unlimited use rentals at low monthly pricing!
- Purchase new systems to transform your business!



### Mat Pro Ultra V

Designed with the aim of increasing the production capabilities of small to medium sized businesses whose target is to own a machine that can also handle foldable and rigid materials used for packaging and product displays.



### Supreme - iS

Developed for busy frame shops looking for a more robust mat cutting solution and, therefore, turns out to be the ideal choice for Custom framers or low volume production framers.



### Plus - iS

Developed and constructed for production framing businesses, and custom framers looking for the best CMC available. Available in two sizes and is capable of doing all cutting from the front and the back, cuts single or multiple openings, V-grooves and pre-assembled double and triple mats.



### Libra

Libra is the perfect mat cutter for professional framers, born to assist the user with excellent performance and extreme precision. The Libra is targeted at companies with medium volume production that require robust and reliable equipment.



### Geminus - iV

The Geminus-iV is the all-in-one solution for any type of cutting, drawing or scoring process that your operation requires. The Geminus is designed for high volume production, featuring dual-bay two station cutting of matboards and more.

VALIANI means...

- ✓ High quality Italian Engineering
- ✓ Precision & Creativity
- ✓ Versatility
- ✓ Reliability & Profitability
- ✓ Superior Customer Support



Supports Interchangeable Heads

For Pricing & Information on Valiani Computerized Mat Cutters, call Omega today at 1-877-452-3799



**“Month to Month” Rental Programs - Unlimited Use**

*Prices listed below reflect pricing at the time of printing. Please contact Omega to get up-to-the-minute pricing.*

<b>Mat Pro® Ultra</b>	<b>Basic Package</b>	<b>Custom Package</b>	<b>Mat Pro® Ultra BC</b>	<b>Basic Package</b>	<b>Custom Package</b>
<b>User License Fee</b> (one time only)	<i>Call for current pricing</i>	<i>Call for current pricing</i>	<b>User License Fee</b> (one time only)	<i>Call for current pricing</i>	<i>Call for current pricing</i>
<b>Monthly Rental Fee</b> (first 36 payments)	<i>Call for current pricing</i>	<i>Call for current pricing</i>	<b>Monthly Rental Fee</b> (first 36 payments)	<i>Call for current pricing</i>	<i>Call for current pricing</i>
<b>Monthly Rental Fee</b> (after 36 payments)	<i>Call for current pricing</i>	<i>Call for current pricing</i>	<b>Monthly Rental Fee</b> (after 36 payments)	<i>Call for current pricing</i>	<i>Call for current pricing</i>

Size 150 CMC (60" x 40") only - Includes your choice of machine stand: 2 Position Combo Horizontal, Vertical or Table-Top

**Purchase Pricing**

<b>Machine Model</b>	<b>Size Available</b>	<b>Basic Package</b>	<b>Custom Package</b>
<b>Mat Pro® Ultra</b>	100 CMC (40" x 32") 120 CMC (48" x 32") 150 CMC (60" x 40") XXL CMC (104" x 60")	<i>Call for current pricing</i>	<i>Call for current pricing</i>
<b>Mat Pro® Ultra BC</b>	150 CMC (60" x 40") XXL CMC (104" x 60")	<i>Call for current pricing</i>	<i>Call for current pricing</i>
<b>Mat Pro® Ultra V</b>	150 CMC (60" x 40")	<i>Call for current pricing</i>	<i>Call for current pricing</i>
<b>Supreme®-i</b>	120 CMC (48" x 32") 150 CMC (60" x 40") 260 CMC (104" x 46")	<i>Call for current pricing</i>	<i>Call for current pricing</i>
<b>Plus®-i</b>	120 CMC (48" x 32") 150 CMC (60" x 40") 150 DSCMC (60" x 40")	<i>Call for current pricing</i>	<i>Call for current pricing</i>
<b>Libra®-i</b>	CMC (67" x 49")	<i>Call for current pricing</i>	<i>Call for current pricing</i>
<b>Geminus® - i</b>	CMC (74" x 49")	<i>Call for current pricing</i>	<i>Call for current pricing</i>

**Basic Package Includes :** 40° Green Cutting Head, choice of stand (Mat Pro Ultra only), Dell® Computer System w/ Windows 8, V-Studio software, stainless steel slip-sheet (non vacuum, standard size machines only), 1 box of L100 extended life blades, two (2) years of unlimited technical support and two (2) year factory warranty on all non-wear parts. One (1) year manufacturers warranty of computer system. All warranties begin on the date of shipment.

**Custom Package Includes :** The complete Basic Package plus the 45° “Blue” or 45° “Red” cutting head, 90° Grey cutting head and “Gold” MatStylus Deluxe Drawing head.

# VALIANI

Cutting Machines



## Valiani ASTRA Manual Mat Cutter

The Valiani Astra 120/150 bench top mat cutting machine has evolved to the next level. The Astra is available in cutting capabilities of 1200mm (48") and 1500mm (60") and cuts mats of varying thickness. The machine, as standard, is supplied with magnetic stops, measuring stops, easy to use blade holder and an extension arm.

The cutting head slides on four ball bearings which glide on two sturdy non-warping tempered steel tracks constantly cleaned by four small brushes placed beneath it.

The measuring stops are simply adjusted and allow precision cuts on all 4 sides of the mat board, therefore drastically reducing overcuts and undercuts.

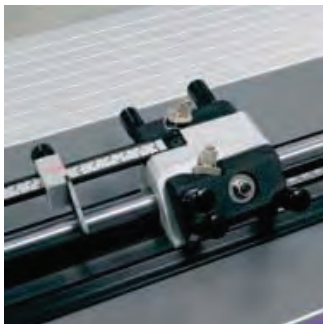

Each cutting head rotates 45° and 90° on two ball bearings. This makes cutting effortless eliminating operator hand and wrist fatigue. The aluminum mat guide, in perfect alignment with the cutting head, ensures an accurate cut on the entire surface of the mat.



The blade holder is manufactured using high precision technology. It allows you to easily alter the blade depth by simply turning the adjustment screw to reduce or increase depth and ensures a perfectly straight cut at all times. Cuts mats of varying thickness from paper to mat boards up to 3.5mm (8 ply) thick.



The magnetic stop is a revolutionary feature. Cutting is quicker and more precise. It eliminates the necessity of resetting the opening dimension stops for all 4 sides since the magnets automatically adjust to the external mat size and cuts mats of varying sizes without resetting the stops when you maintain the same border size. The magnetic stops will increase your production.

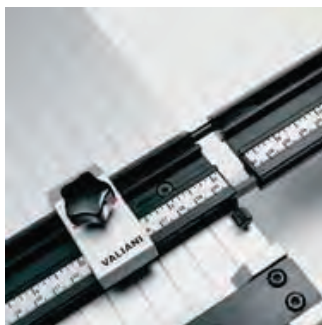

The right side extension arm allows for cuts of up to 120cm (48"). Simple to insert, it provides rigid and stable support for acquiring and cutting to size large mat boards. Includes a measuring stop to help set up the mat dimensions.

### Innovative Italian Design

The cutting head slides on four ball bearings which glide on two sturdy durable tempered steel tracks that are constantly cleaned by two small brushes. This reduces wear and helps keep the cutting motion smooth and straight – even with heavy use.

The magnetic stop is a revolutionary Valiani feature, making routine cutting quicker and more consistent, even for multiple operators. The cutting head stop scale eliminates the necessity of resetting the start of cut dimension stop for each side, since the stop guide automatically references to the external mat size and maintains the same border size. The magnetic stop will increase your production rates – without over or undercutting.

### Fully Loaded - Right out of the box

The Astra is fully accessorized in its standard version – supplied with precision magnetic stops, integrated clamp lifting lever, precision blade-holding cartridges, and a right-side extension arm for board sizing. Don't pay extra for the features you need most!



### The most copied manual mat cutter, ever.

The Valiani Astra 120/150 mat cutter has several features that have been copied by other manufacturers over the years, but never duplicated as a complete system. A classic, simple and supremely reliable machine, the Astra was (among) the first machine(s) to use a warp-free aluminum base, and introduced the industry's first magnetic stops. The Astra is available in cutting capacities of 49"-120" model and 61"-150" model.

### Micro-adjustable Blade Cartridges

Another industry first – the bevel and straight (90°) blade holders are manufactured using high precision machining technology. The rigid, pointed-tip blade is precisely positioned in the cartridge, with a simple micro-adjustable depth adjustment screw to reduce or increase depth and ensure a perfectly straight "hook-free" cut at all times. The Astra allows you to quickly and consistently set blade depth for mats of varying thicknesses; from the thinnest foil mat on up to 8-ply (3.5mm) thick rag board.

Item # \_\_\_\_\_ Description \_\_\_\_\_

- AST120 Valiani Astra 120 Manual Mat Cutter 
- AST150 Valiani Astra 150 Manual Mat Cutter 

 Items with this symbol are Special Order from the U.S.

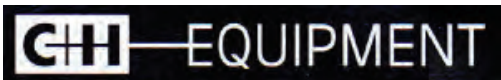

**C+H Advantage Pro Mat Cutters**

With over 40 years of advancements and innovation the C&H Advantage PRO from Nielsen Bainbridge has been a leader in mat cutters. Available in 2 sizes (48" and 60") with a uniquely designed squaring arm that is included along with the latest measuring stop for increased speed and accuracy found on Pro Plus models only. A one point Mat Guide adjustment for quick & easy setting of the mat boarders. The cutting head rides on a 5/8" precision steel rod which connects to a pair of heavy duty hinges, all attached to a sturdy laminated MDF base. These units are the best value for the money and will give you many years of service.

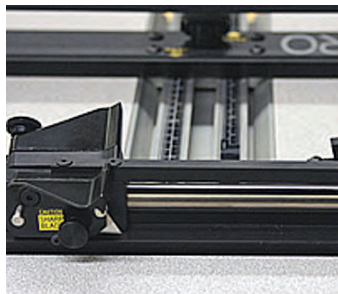

Item #	Model
4607	48" C&H Advantage Pro Mat Cutter
4608	60" C&H Advantage Pro Mat Cutter



• C+H Mat Blades  
See Page 21

Item #	Accessory
4615-36	Squaring Arm (36") for C+H Advantage Pro
4606	Production Stops for 60" C&H Advantage Pro LE



**C+H BG6100 Vertical Wall Cutter**

The C & H BG6100 Wall Mounted Board and Glass Cutter takes the stress out of cutting glass, foamboards and matboard. The BG6100 has a twin cutting head, so there is no need for a blade or head change when switching between glass and foamboard, and can clamp material up to 1/2" (13mm) thick.

- Space saving, wall mounted cutting solution for glass, acrylic, foamboard & matboard
- Self-lubricating twin cutting head switches between glass and foamboard/matboard, with no tool changes required
- Twin handle cutting head for cutting balance control
- Heavy-duty, Teflon coated clamp / v-rail assembly provides a stable track for the cutting head and holds board and glass securely in place, up to 1/2" (13mm) thick
- Line of sight cutting edge along the clamping bar offers clear visual reference, allowing the trimming of mounted art right to its edge easily and without guesswork
- Vertical measuring scale allows quick reference of material dimensions in both width and height
- Production flip-stop to assist with repeating the same dimensions for high volume work

Item # **4620** C+H BG6100 Vertical Wall Cutter



• Item # 4620



Twin Handle Cutting Head



V-Rail Clamping Lever



Vertical Measuring Scale



Line of sight cutting edge



Production Flip Stop



Cuts Foam Board up to 1/2" thick

Items with this symbol are Special Order from the U.S.



# Foster Keencut

Omega is the master distributor for Keencut products for the framing industry in North America

## Excalibur 1000X & 5000 Vertical Cutter

The unique Excalibur 5000 features two cutting heads with four different cutting tools mounted on the same head for instant selection. The counterbalance ensures an easy glide cutting action, prevents damage when loading sheet materials, minimizes operator fatigue and increases production. The Twin Wheel Cutting Head cuts 1/8" uncoated masonite and mat board. A standard medium duty utility blade accurately cuts Foam-board, Gatorboard, Sintra, corrugated cardboard, coroplast up to 1/2" thick. The scoring blade is used for acrylics and other rigid plastics. The tungsten carbide cutting wheel scores glass and mirrors up to 1/4" thick.

The Excalibur 1000x series vertical cutter features a single sliding counter-balanced head with 3 cutting and scoring tools ready for instant use. With a rigid clamping system, a set-for-life squaring mechanism and the standard wall mounting or optional free-standing kit, the Excalibur 1000X provides a noiseless, dust-free and cost effective cutting solution for materials used in a modern sign or graphic workshop.

- Easiest vertical cutter to keep square
- Ready mounted integral tools with rotating wheel for maximum convenience
- Control for cutting rigid PVC up to 1/2" thick
- Wall mounting kit included
- Pressure sensitive clamp
- Complete set of production stops
- Fitted counterbalance (Excalibur 5000 only) – less fatigue, accidents & easy loading of materials
- Single cut line & sightline strip for maximum accuracy with all tools
- 5 Year guarantee (excluding replacement cutting wheels)
- 20 Year free replacement on all bearings

Item # \_\_\_\_\_ Model \_\_\_\_\_

**EXC1000X** Keencut 1000X 63" Vertical Cutter 

**EXC5000** Keencut 5000 63" Vertical Cutter 

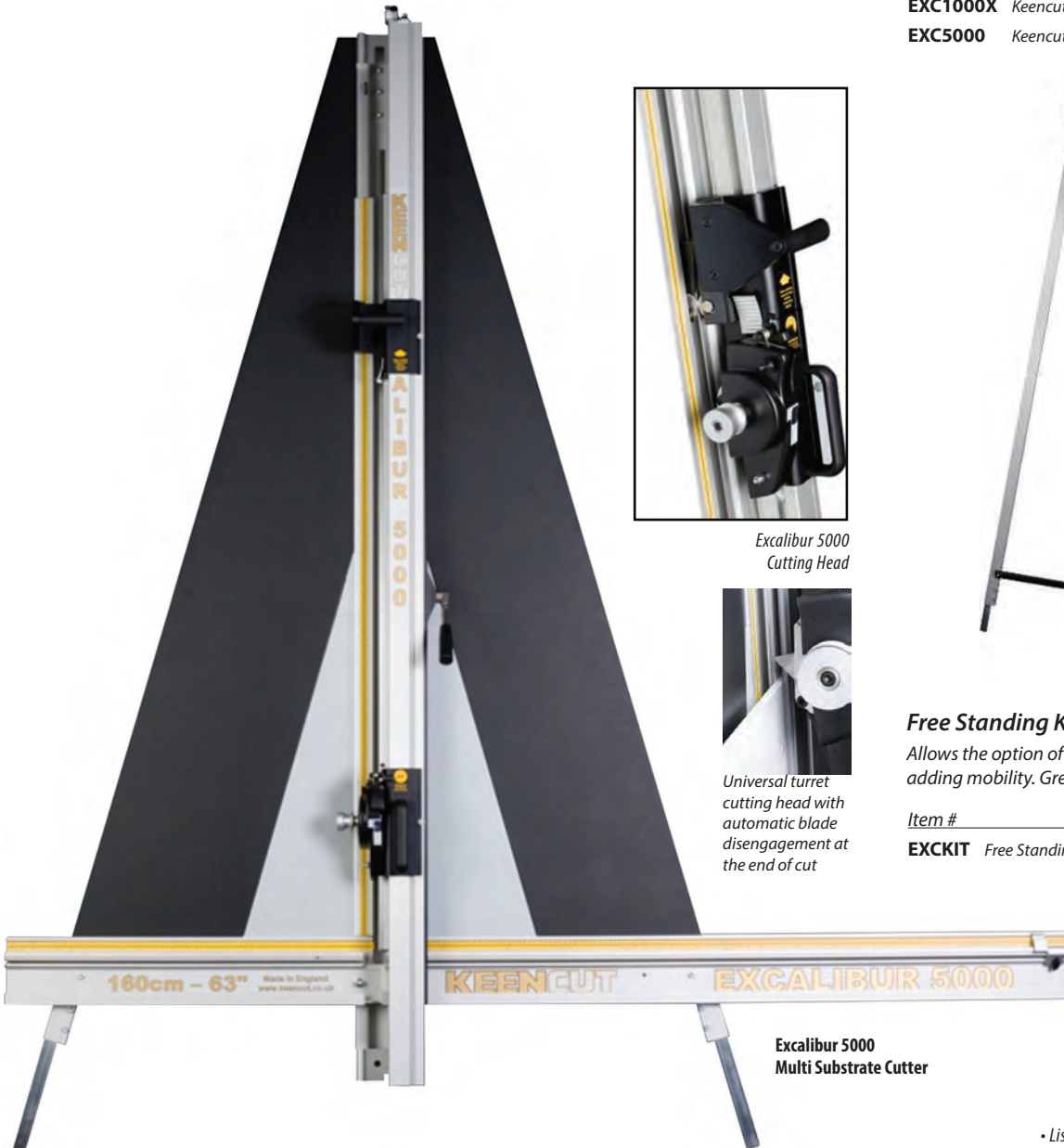

Excalibur 5000 Cutting Head

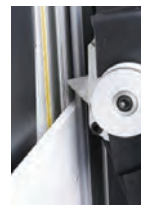

Universal turret cutting head with automatic blade disengagement at the end of cut



### Free Standing Kit for 63" 1000x & 5000

Allows the option of not mounting to a wall while adding mobility. Great for larger production facilities.

Item # \_\_\_\_\_ Description \_\_\_\_\_

**EXCKIT** Free Standing Kit for Excalibur Cutters

• List prices shown; Call for current specials

For Pricing & Information on Keencut equipment call Omega today at 1-877-452-3799

 Items with this symbol are Special Order from the U.S.

# Foster Keencut

## Vertical Cutters • Parts & Accessories

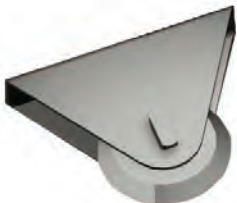

### Tungsten Carbide Glass Scoring Wheel

Tungsten carbide glass scoring wheel is made of high quality carbide, precision machined and built for extra durability and long scoring life. Lasts for months. Made especially for Keencut multi-substrate cutters.

Item # \_\_\_\_\_ Description \_\_\_\_\_

**TCGLCWH** Tungsten Carbide scoring wheel



### Glass Cutting Cartridge

For older versions of the Excalibur 1000x (Single Tool cutter) holds carbide scoring wheel for insertion into the cutting head.

Item # \_\_\_\_\_ Description \_\_\_\_\_

**GLCUTCAR** 1000x Glass Cutting Cartridge



Medium Duty Blade

• Expertly crafted in England from Sheffield Steel!



Heavy Duty Blade (.080)

### Board Cutting Blades

Medium and Heavy Duty blades for cutting card-board, foam board, Gator Board, Coroplast, and Sintra. Made in England from world-renowned Sheffield Steel, provides a longer life and superior edge for performance cutting up to 1/2" thick.

Item # \_\_\_\_\_ Description \_\_\_\_\_

**MDBLADES** Medium Duty Blades (100)

**HDBLADES** Heavy Duty Blades (100)



### Sightline Strips

Sight-line strip is fixed to the clamp and then trimmed by the cutting blade to give an accurate guide when cutting to trim lines, the edge of an image or pencil marks. For Excalibur Series vertical cutters (Pack of 3 strips)

Item # \_\_\_\_\_ Description \_\_\_\_\_

**EXCSLSTR** Pack of 3 Sightline Strips



### Composite Twin-Wheel Cutter Head

The twin-wheel head shears 1/8" Masonite, heavy mat board and 3/8" PVC board.

Item # \_\_\_\_\_ Description \_\_\_\_\_

**CTWHCH** Composite Twin Wheel Cutter Head



### Twin-Wheel Replacements

Replacement wheels attach to twin-wheel head with attached hardware.

Item # \_\_\_\_\_ Description \_\_\_\_\_

**TWCREPW** Replacement wheels for cutter



### Excalibur 5000 Complete Cutting Head Replacement

This unit houses four precision cutters in one: a twin-wheel cutting head, a utility blade, a scoring blade for acrylic and a tungsten carbide glass scoring wheel. Designed exclusively for the Excalibur 5000, it features the turret cutting head that enables the user to easily switch between cutters for different materials. Assembly instructions included.

Item # \_\_\_\_\_ Description \_\_\_\_\_

**CCHREP** Excalibur 5000 Complete Cutting Head

# Foster Keencut

Manual Mat Cutters

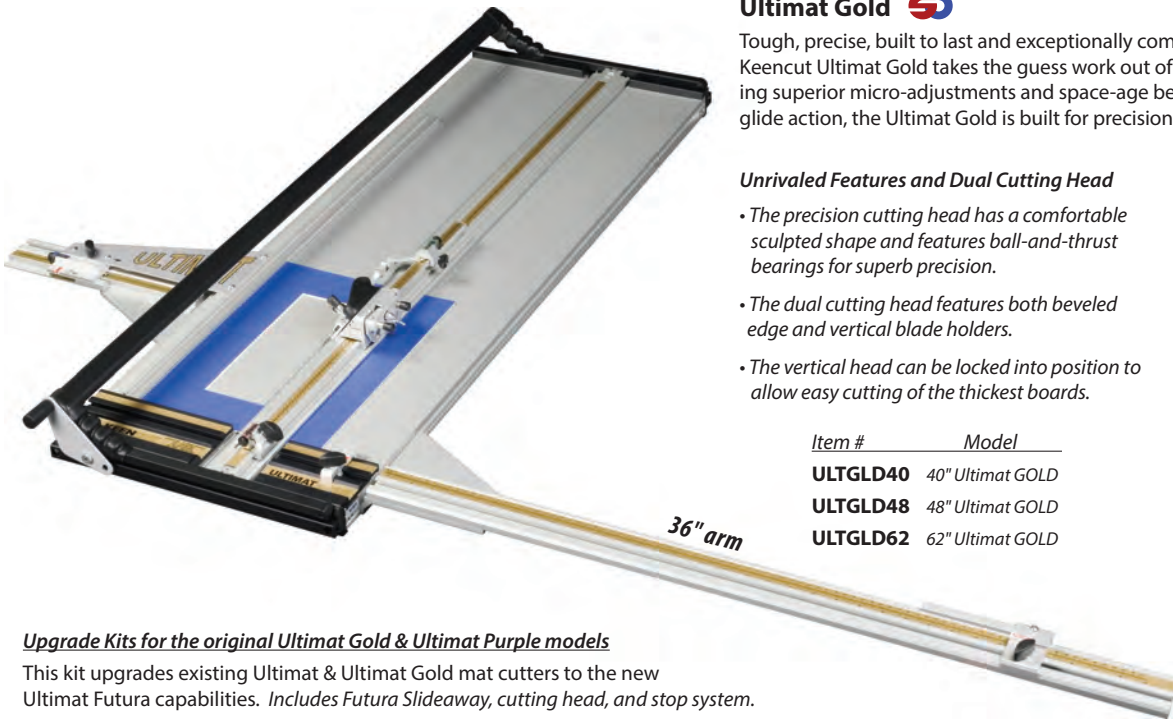

## Ultimat Gold

Tough, precise, built to last and exceptionally comfortable to use, the Keencut Ultimat Gold takes the guess work out of creating perfect mats. Offering superior micro-adjustments and space-age bearings that provide silent-gliding action, the Ultimat Gold is built for precision, ease of use and versatility.

### Unrivaled Features and Dual Cutting Head

- The precision cutting head has a comfortable sculpted shape and features ball-and-thrust bearings for superb precision.
- The dual cutting head features both beveled edge and vertical blade holders.
- The vertical head can be locked into position to allow easy cutting of the thickest boards.

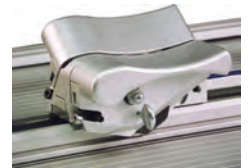

Item #	Model
ULTGLD40	40" Ultimat GOLD
ULTGLD48	48" Ultimat GOLD
ULTGLD62	62" Ultimat GOLD

### Upgrade Kits for the original Ultimat Gold & Ultimat Purple models

This kit upgrades existing Ultimat & Ultimat Gold mat cutters to the new Ultimat Futura capabilities. Includes Futura Slideaway, cutting head, and stop system.

Item #	Upgrade Kit for:	Item #	Upgrade Kit for:
UGFUT40	40" Ultimat GOLD	UPFUT40	40" Ultimat (Purple)
UGFUT48	48" Ultimat GOLD	UPFUT48	48" Ultimat (Purple)
UGFUT62	62" Ultimat GOLD	UPFUT62	62" Ultimat (Purple)

 All Mat Cutters & Upgrade Kits are Special Order items from the U.S.

### Keencut Mat Blades:

Item #	Blades (QTY)
TSBL012	Tech S .012 (100ct)
TSBL015	Tech S .015 (100ct)
TDBL012	Tech D .012 (100ct)
TDBL015	Tech D .015 (100ct)



## Ultimat Futura

With the creation of the Ultimat Futura, we've made the Ultimat Gold (above) even better. Featuring a new cutting head with self-aligning roller bearings, the Ultimat Futura represents the future of manual mat cutters – and offers the smoothest cut ever.

### The Ultimat Futura Includes:

- Switchable magnetic blade holders for cutting different thicknesses
- Large-diameter roller thrust bearings on the cutting head for total control of both blade carriers. No flex, side play or hooks.
- Base plate that accommodates all accessories.
- Roller lift and hold system.
- Patented micro-stops.

Item #	Model
ULTFUT40	40" Ultimat Futura
ULTFUT48	48" Ultimat Futura
ULTFUT62	62" Ultimat Futura

### Futura Accessories:

Item #	Futura Accessory
BESA24	2x Base Extension Support Arm 24"
MARGUKIT	30" Extended Margin Guide Kit
MACGAUG	Multi-angle Cutting Gauge
REVBEVST	Reverse Bevel Stop



Extended Margin Guide Kit

 Items with this symbol are Special Order from the U.S.



# Foster Keencut



## Keencut Advanced Rotary Cutter (ARC)

Keencut's Advanced Rotary Cutter (ARC) is the only rotary trimmer with dual cutting wheels, providing two-way cutting flexibility and guaranteed sharpness with its tungsten steel blades. Its unique monorail bearing system design, positioned underneath the surface of the baseboard, makes the ARC specifically suited for the cutting of ultra-thin and thin materials – without buckling on the edge of the blade. Additionally, the ARC guarantees that the cut is consistent over the entire length of the material – no bows or buckles in the middle.

### Perfect for Cutting:

- Mountboards
- Paper
- Photo Paper
- Tissue
- Film
- Banners
- Aluminum plate (.004")
- Self-adhesive vinyl
- Flexible sheet materials

Item #	Model
RT60606	42" Rotary Cutter
ARC60	60" Rotary Cutter

## Laser Trued Steel Tip Straight Edges

The laser-trued Foster Keencut Straight Edge, in silver anodized aluminum, is a superb straight edge for use in marking, drawing, scoring or cutting. In fact it can be used with all types of hand-held tools where accuracy is required. The Safety Straight Edge is strong, precise and portable and comes fitted with two full-length grip strips to steady the straight edge and protect sensitive surfaces. Safety Straight Edges are safe to use with the integral finger guard and a full-length stainless steel bead to resist wear to the edge and the tools. These tools are available in seventeen convenient sizes.

Item #	Length	Item #	Length
SSE18	18" straight edge	SSE60CM	60cm straight edge
SSE24	24" straight edge	SSE75CM	75cm straight edge
SSE30	30" straight edge	SSE90CM	90cm straight edge
SSE36	36" straight edge	SSE105CM	105cm straight edge
SSE42	42" straight edge	SSE120CM	120cm straight edge
SSE48	48" straight edge	SSE135CM	135cm straight edge
SSE54	54" straight edge	SSE150CM	150cm straight edge
SSE60	60" straight edge	SSE180CM	180cm straight edge
SSE72	72" straight edge		



- Lightweight anodized aluminum frame
- Embedded steel edge for lasting accuracy
- Two full length grip strips protect and hold your material in place
- Laser trued accuracy to within 1mm

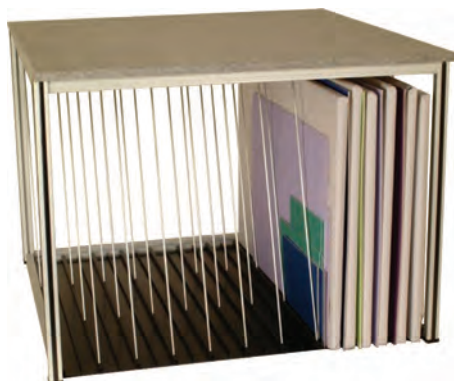

## Keencut Mat Board Storage Unit

This Matboard Storage Unit helps maximize use of space in small shops and provides significant savings on storage costs. Additionally, it combines as a great work table for your Ultimat mat cutter. Avoid edge damage by storing your unwrapped matboard and finished frames in this sturdy unit. The smooth internal base that includes heavy-duty interlocking extruded plastic channels allows unwrapped mat board, or even finished frames, to be slid in or out without edge damage.

Item #	Model
MBSTOR7	7-slot storage unit
MBSTOR10	10-slot storage unit



## REGULAR MATBOARD

### Decorative Matboard

Decorative Matboards, with a light cream core, provide an unrivaled range of colors and textures for traditional non-conservation framing.

- Decorative facing papers
- Natural cream core and backing
- Surface, core and backing paper buffered with calcium carbonate to alkaline reserve of 3-5%
- Available in 32"x40" and 40"x60"

Recommended For:

- Decorative framing and general presentations
- Open end reproductions
- Posters and decorative art



### International Whitecore

International Whitecore, a non-conservation white core matboard, provides the aesthetic and design benefits of a bright-white level.

- Decorative facing papers
- Stay-white core and backing
- Surface, core and backing paper buffered with calcium carbonate to alkaline reserve of 3-5%
- Available in 32"x40" and 40"x60"

Recommended For:

- Decorative framing and general presentations
- Open end reproductions
- Posters and decorative art

## Crescent Accents™

Decorative patterns on alpha-cellulose conservation matboard

### Crescent Accents

Crescent Accents are 100% virgin alpha-cellulose, conservation-grade matboards with printed decorative surface patterns.

- Conservation grade surface papers for optimum bleed and fade resistance
- Facing papers exceed minimum standards for fade and bleed as set by F.A.T.G.
- 100% virgin alpha-cellulose surface, core and backing papers
- pH 8.0-9.5. Buffered with calcium carbonate to an alkaline reserve of 3-5%
- Available in 32"x40" and 40"x60"

Recommended For:

- Fine Art Prints
- Limited Editions
- Valuable Documents
- Photography

## Crescent Select™

Alpha-cellulose conservation matboard

### Crescent Select Matboards

Crescent Select Matboards are made of alpha-cellulose (wood pulp) fibers that have been chemically treated to eliminate the acids and lignins that can degrade the matboard and the artwork. Alpha-cellulose based matboards are suitable for minimum levels of conservation framing and as an alternative to non-conservation matting.

- Conservation grade surface papers for optimum bleed and fade resistance
- Facing papers exceed minimum standards for fade and bleed as set by F.A.T.G.
- 100% virgin alpha-cellulose surface, core and backing papers
- pH 8.0-9.5. Buffered with calcium carbonate to an alkaline reserve of 3-5%
- Available in 32"x40" and 40"x60"

Recommended For:

- Fine Art Prints
- Limited Editions
- Valuable Documents
- Photography

## ULTIBLACK™

### Crescent Select UltiBlack

Crescent Select UltiBlack Matboards are made of alpha-cellulose (wood pulp) fibers that have been chemically treated to eliminate the acids and lignins that can degrade the matboard and the artwork. Alpha-cellulose based matboards are suitable for minimum levels of conservation framing and as an alternative to non-conservation matting.

- Conservation grade surface papers for optimum bleed and fade resistance
- Facing papers exceed minimum standards for fade and bleed as set by F.A.T.G.
- 100% virgin alpha-cellulose surface, core and backing papers
- pH 8.0-9.5. Buffered with calcium carbonate to an alkaline reserve of 3-5%
- Available in 32"x40" and 40"x60"

Recommended For:

- Fine Art Prints
- Limited Editions
- Valuable Documents
- Photography

## BriteCores™

### Crescent BriteCores

BriteCores are two-sided conservation quality matboards. They feature brightly colored cores with matching surface papers on one side and a white or black surface paper on the other side

- Acid-free and lignin-free
- Extra-thick bright-colored conservation cores with matching conservation surface papers
- Colors pigmented for bleed and fade resistance
- Buffered with calcium carbonate to an alkaline reserve of 3-5%

Recommended For:

- Limited edition prints
- Contemporary color photography
- Sports Memorabilia & Animation cels

## Black Core

### Black Core Matboard

Black Core Matboards add contrast and drama to non-conservation framing.

- Decorative facing papers
- Solid black core and backing
- Exclusive non-scuff backing paper
- Surface, core and backing paper buffered with calcium carbonate to alkaline reserve of 3-5%
- Available in 32"x40" and 40"x60"

Recommended For:

- Decorative framing and general presentations
- Open end reproductions
- Posters and decorative art





**Crescent Rag Mat** 

For centuries, cotton rag paper, prized for strength, purity and stability, has been the choice of artists, writers and printers. Today it is specified for currency, stock certificates and government documents. Cotton rag matboard was designed specifically for the Metropolitan Museum of Art in New York in the late 1920s.

Today, virtually all museums and libraries rely on cotton rag matboard, often referred to as museum board. Crescent's entire line of cotton **RagMat**, the industry's most trusted brand of cotton rag matboard, is still produced following the time-honored practice of making paper from cotton fiber. It's a Crescent tradition that continues to stand the test of time.



**Cotton RagMat is...**

**QUALITY:** Cotton RagMat is the only mounting and matting board guaranteed safe next to any artwork. The quality of cotton RagMat is simply unsurpassed and is the natural choice when the highest levels of protection are required.

**NATURAL:** Cotton is naturally acid-free and lignin-free. Cotton RagMat is processed without harsh chemicals or additives.

**TIME-TESTED:** For over 1500 years cotton has been both the courier and curator of history. Priceless documents such as the Gutenberg Bible, Shakespeare's first folio, and the U.S. Constitution and Bill of Rights exist today because they were penned on cotton paper.

**ENVIRONMENTALLY FRIENDLY:** Cotton is an annually renewable resource. Cotton RagMat is processed without harsh chemicals or additives.

**TRUSTED:** Cotton is preferred by museums and preservationists and has been trusted by artists, historians and writers for centuries.

**GUARANTEED:** Cotton RagMat is guaranteed safe next to artwork. RagMat is the only matting and mounting board backed by a lifetime warranty.



RagMat meets museum conservation standards as set by the Fine Arts Trade Guild. Made of strong cotton fibers, which are naturally acid-free and lignin-free it is also annually renewable and environmentally friendly. Cotton RagMat is the only matboard guaranteed safe next to any artwork.

- Facing papers exceed minimum standards for fade and bleed as set by F.A.C.T.S. and F.A.T.G.
- pH 8.5 - 9.5
- Buffered with calcium carbonate to an alkaline reserve of 3 -5% (except RagMat Museum Solids - Unbuffered)
- 4 ply and 8 ply thicknesses. (Consult color specifier)
- Meets Museum Standards as set by F.A.C.T.S. and F.A.T.G.

**Intended for:**

- Valuable works of original art
- Surface papers are pigmented for fade and bleed resistance.
- Items of historical importance

**MOORMAN**<sup>TM</sup>  
FABRIC MATBOARD

*Crescent's exclusive Moorman line of matboard delivers unparalleled quality, elegant color, rich texture and the style of European craftsmanship.*



**White Core Suede**

*High quality fade and bleed resistant suede surfaces on premium white conservation core and backing*



**Black Core Suede**

*High quality fade and bleed resistant suede surfaces on decorative black core and backing*

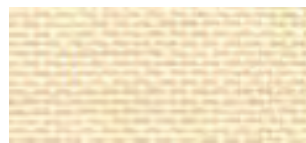

**Natural Linen**

*Richly textured fade and bleed resistant linen surfaces on premium white conservation core and backing*



**Linen**

*Classic tightly-woven linens on premium white conservation quality core and backing*



**Sheer Silks**

*The subtle elegance and soft sheen of silk on premium white conservation core and backing*

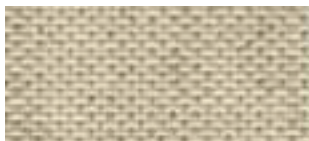

**Rustic Linen**

*Traditional linen on premium white conservation quality core & backing*



**Pacific Linen**

*Stylish linens with the look of pulled-thread on premium white conservation quality core and backing*



**Leather & Club Leather**

*Beautifully styled, richly textured leathers on black core and backing*





## PAPER MATBOARD • 32 x 40 (4 Ply)

C33	White & Cream Smooth						
C34	White & Cream Pebble						
C900	Red	C905	Violet	C912	India	C918	Very White
C902	Yellow	C907	Wine	C915	Fog	C919	Ivy Green
C903	Soft Green	C909	English Rose	C916	Autumn Mist		
C921A	Smooth Black						
C924	Dark Gray	C935	Copely Gray	C948	Sand		
C934	Pearl	C939	Dark Green	C960	White		
C961	Cream	C972	French Blue	C978	Congo Green	C986	Tampico Brown
C962	French Gray	C974	Dawn Gray	C979	Dusk	C987	Palm Beach White
C968	Old Gold	C975	Stone Gray	C983	Saddle Tan	C988	Williamsburgh Green
C969	Silver	C976	Bar Harbor Gray	C984	Oak Brown	C989	Raven Black
C970	Gold	C977	Newport Blue	C985	Pyro Brown	C993	Kelly Green
C994	Chamois Gold	C996	Russet				
C995	French Lilac	C997	Sable				
C1000	Pompano Beach White	C1001	Moss Point Green	C1002	Mist Gray		
C1020	Silver Foil (1-ply)	C1021	Gold Foil (1-ply)				
C1008	Ivory	C1027	Silver Gray	C1042	Williamsburg Red	C1067	Storm Blue
C1009	Light Jonquil	C1028	Spice Ivory	C1045	Grass Green	C1073	Biscay Blue
C1014	Olde Grey	C1029	Wheat	C1047	Williamsburg Blue	C1076	Las Cruces Purple
C1015	Grey Violet	C1031	Light Teal	C1051	Olde Tan	C1077	Burnt Orange
C1016	Concord	C1032	Dark Olive	C1053	Delft Blue	C1078	Madagascar Pink
C1019	Photo Grey	C1033	Dark Ash	C1054	Baltic Blue	C1080	Bimini Blue
C1023	Crimson	C1038	Maroon	C1056	Boulder Brown	C1081	Volcano Blue
C1024	Dusty Blue	C1039	Auburn	C1057	Redwood	C1082	Marine Blue
C1025	Medium Gray	C1040	Classic Brown	C1061	Sandstone	C1084	Avocado
C1085	Rust	C1092	Azure				
C1087	Persimmon	C1095	Antique Buff				
C1088	Mist	C1096	Sepia				
C1089	Sauterne	C1097	Fudge				
C1090	Pewter						
C3214	Chinese Red	C3291	French Buff	C3297	Arctic White		
C3290	Snow White	C3293	Antique White	C3331	Sage		
C3314	Limoge Pink	C3323	Real Teal	C3333	Black Watch		
C3315	Porcelain	C3325	Mandarin	C3342	Midnight Green	C3352	Light Umbria
C3319	Topaz	C3326	Lapis	C3343	Off White	C3354	Winter White
C3320	Saffron	C3328	Art Deco Green	C3344	Manor Black	C3357	Aqua Green
C3358	Indigo	C3380	Hay				
C3359	Sundown Shadow	C3387	Rattan				
C3360	China Blue	C3921	Black & White Pebble				

## PAPER MATBOARD • 40x60 Double Thick (6 Ply)

C846 White & Cream

## REGULAR MATBOARD • 40 x 60 (4 Ply)

C81027	Silver Gray	C81090	Pewter	C83300	Alabaster	C8924	Dark Gray	C8974	Dawn Gray	C8994	Chamois Gold
C81028	Spice Ivory	C81096	Sepia	C83326	Lapis	C8934	Pearl	C8977	Newport Blue	C8996	Russet
C81038	Maroon	C831	Smooth Black	C83331	Sage	C8948	Sand	C8978	Congo Green	C8997	Sable
C81051	Olde Tan	C83214	Chinese Red	C83344	Manor Black	C8961	Cream	C8983	Saddle Tan		
C81081	Volcano Blue	C83291	French Buff	C8900	Red	C8962	French Gray	C8987	Palm Beach White		
C81085	Rust	C83293	Antique White	C8912	India	C8968	Old Gold	C8988	Williamsburgh Green		
C81088	Mist	C83297	Arctic White	C8918	Very White	C8969	Silver	C8989	Raven Black		

## BLACK CORE MATBOARD • 32 x 40 (4 Ply)

C6915	Fog	C6989	Raven Black	C61025	Medium Gray	C61032	Dark Olive	C61073	Biscay Blue	C63311	Granite
C6977	Newport Blue	C61002	Mist Gray	C61027	Silver Gray	C61033	Dark Ash	C61088	Mist	C63326	Lapis
C6984	Oak Brown	C61019	Photo Grey	C61028	Spice Ivory	C61038	Maroon	C63297	Arctic White	C63344	Manor Black
C6988	Williamsburgh Green	C61023	Crimson	C61029	Wheat	C61061	Sandstone	C63300	Alabaster		

## BLACK CORE MATBOARD • 40 x 60 (4 Ply)

C86989 Raven Black C863297 Arctic White

## SILKI PAPER MATBOARD • 32 x 40 (4 Ply)

C4128 Haze Green C4130 Smoked Pearl C4131 Oyster White C4137 Champagne C4140 White

## PRECIOUS METALS PAPER MATBOARD • 32 x 40 (4 Ply)

C3703 Gunmetal C3712 Rouge Gold

## FLORENTINE METALLICS PAPER MATBOARD • 32 x 40 (4 Ply)

C964 Silver C965 Red Gold C967 Medium Gold

## FLANNEL PAPER MATBOARD • 32 x 40 (4 Ply)

C3300 Alabaster C3307 Devonshire Blue C3311 Granite C3346 Moss

**CRESCENT SELECT • 32 x 40 (4 Ply)**

C5647 Carnation	C9530 Hedge Hog	C9568 Make-Up	C9602 Guacamole	C9806 Dove	C9871 Rose Bush
C5648 Peony	C9531 Spinach	C9569 Coho	C9603 Underbrush	C9807 Off White	C9872 Irish Green
C5651 Bluebird	C9532 Olive Branch	C9570 Sushi	C9604 Blarney	C9808 Ivory Art	C9873 Red Light
C5653 Robins Egg	C9533 Bonsai	C9571 Bandage	C9605 Tealy Dan	C9809 Twilight	C9874 Red Line
C9500 White Glove	C9535 Turf	C9572 Fiji Coral	C9606 Jaws	C9810 Tawny	C9875 Saffron
C9501 White Collar	C9536 Frond	C9573 Cranberry Sauce	C9607 Blue Chip	C9811 Putty	C9876 Mandarin Orange
C9502 White Sale	C9537 Envy	C9574 Marooned	C9608 Sweet Tart	C9812 Old Ivory	C9877 Midnight Green
C9503 White Hot	C9538 Deep Woods	C9575 Rare	C9610 Code Red	C9813 Sandstone	C9878 Aqua Green
C9504 White Lie	C9539 Riptide	C9576 Valentine	C9611 Peat Moss	C9814 Autumn Gold	C9879 Purple Iris
C9505 White Wash	C9542 Blue Monday	C9577 Stop	C9612 Fuzz	C9815 Fawn	C9880 Royal Blue
C9506 Egg White	<del>C9543 Fathom</del>	C9578 Rusted	C9613 Super White	C9816 Ginger	C9881 Real Teal
C9507 White Elephant	C9544 Chicago Blues	C9579 Mudslide	C9614 Glow	C9818 Sienna	C9882 Cornflower
C9508 White Sands	C9545 Glacier	C9581 Hot Sauce	C9615 Cream Puff	C9820 Forest Green	C9884 Napa Valley Red
C9509 Half & Half	C9546 Blue Satin	C9582 Yam I Am	C9616 Honey Wheat	C9822 Sierra Olive	C9885 Jeans
C9510 Froth	C9547 In A Fog	C9583 Peanut Butter	C9618 Tater	C9823 Black Forest	C9886 Dark Purple
C9511 Fossil	C9548 Blue Lilac	C9584 Catcher's Mitt	C9621 Bud	C9826 Mocha Green	C9887 Black-N-Blue
C9512 Mummy	C9549 Inlet	C9585 Root Beer	C9623 Greenery	C9827 Flag Blue	C9888 Electric Blue
C9513 Sand Trap	C9550 Cabana	C9586 Brown Sugar	C9624 Scrubs	C9828 Mystic Blue	C9889 Deep Blue
C9514 Toasty	C9551 Blue Wave	C9587 Milk Chocolate	C9625 Blue Moon	C9830 Blue Night	C9890 Phantom Blue
C9515 Wet Sand	C9552 NYPD	C9588 Milk Shake	C9627 Ink Spot	C9831 Blue Iris	C9891 Teal Teal
C9516 Tusk	C9553 Moody Blue	C9589 Bambi	C9628 Punch	C9832 Stormy Blue	C9892 Deep Orange
C9518 Summer	C9554 Pharaoh	C9590 Fresh Brew	C9629 Rhino	C9833 Orange Ade	C9893 Blaze Orange
C9519 Curry	C9555 Steel Drum	C9591 Top Soil	C9630 Meteorite	C9834 Russet	C9894 Golden
C9520 Haystack	C9556 Tempest	C9592 Blizzard	C9631 Coal Mine	C9835 Harvest Brown	C9895 Pewter
C9521 Gold Rush	C9557 Pigeon	C9593 Gravel Road	C9632 Black Belt	C9836 Spice	C9896 Lawn
C9522 Oleo	C9558 Geode	C9594 Concrete	C9633 Morning	C9837 All American Red	C9897 Water Fall
C9523 Omelet	C9559 Plink	C9595 Urban	C9634 Cloudburst	C9838 Brick	C9898 Burnt Orange
C9524 In The Buff	C9560 Easter Egg	C9596 Cubicle	C9635 Nightfall	C9839 Cabernet	C9899 Red Hot
C9525 Sage Advice	C9561 Purple Haze	C9597 Field Mouse	C9800 Baker'S White	C9840 Plum	
C9526 Pickle	C9562 Grape Jelly	C9598 Before Dark	C9801 Chalk	C9842 Coffee Bean	
C9527 Wise Green	C9564 Purple Mountain	C9599 After Dark	C9802 White Art	C9846 Dark Shale	
C9528 Lentil	C9565 Quarry	C9600 Batter	C9804 Pure White	C9848 Jet Black	
C9529 Silly Putty	C9567 Cotton Candy	C9601 Sandpaper	C9805 Coconut Milk	C9869 Red	

C5598 Etched Black    C9870 Silver Star

C9744 Golf Ball

**CRESCENT SELECT • 40 x 60 (4 Ply)**

C89500 White Glove	C89527 Wise Green	C89613 Super White	C89809 Twilight	C89830 Blue Night	C89876 Mandarin Orange
C89501 White Collar	C89533 Bonsai	C89614 Glow	C89812 Old Ivory	C89832 Stormy Blue	C89877 Midnight Green
C89502 White Sale	C89542 Blue Monday	C89618 Tater	C89813 Sandstone	C89833 Orange Ade	C89881 Real Teal
C89505 White Wash	C89552 NYPD	C89632 Black Belt	C89814 Autumn Gold	C89834 Russet	C89882 Cornflower
C89506 Egg White	C89553 Moody Blue	C89633 Morning	C89815 Fawn	C89835 Harvest Brown	C89886 Dark Purple
C89507 White Elephant	C89554 Pharaoh	C89634 Cloudburst	C89816 Ginger	C89837 All American Red	C89889 Deep Blue
C89508 White Sands	C89574 Marooned	C89635 Nightfall	C89818 Sienna	C89838 Brick	C89892 Deep Orange
C89511 Fossil	C89591 Top Soil	C89800 Baker'S White	C89820 Forest Green	C89839 Cabernet	C89894 Golden
C89514 Toasty	C89592 Blizzard	C89801 Chalk	<del>C89821 Ivy Green</del>	C89840 Plum	C89899 Red Hot
C89516 Tusk	C89598 Before Dark	C89804 Pure White	C89822 Sierra Olive	C89846 Dark Shale	
C89518 Summer	C89599 After Dark	C89806 Dove	C89826 Mocha Green	C89848 Jet Black	
C89520 Haystack	C89601 Sandpaper	C89807 Off White	C89827 Flag Blue	C89869 Red	
C89524 In The Buff	C89610 Code Red	C89808 Ivory Art	C89828 Mystic Blue	C89874 Red Line	

C85598 Etched Black

**CRESCENT SELECT • 32 x 40 (6 Ply)**

C29500 White Glove    C29502 White Sale    C29505 White Wash    C29507 White Elephant    C29599 After Dark

**SELECT ULTIBLACKS • 32 x 40 (4 Ply)**

C9900 Baker's White	C9905 Dove	C9916 Mocha Green	<del>C9924 Plymouth</del>	C9930 Plum	C9942 Dark Shale
C9901 Chalk	C9906 Off White	C9917 Forest Green	C9926 All-American Red	C9932 Fawn	C9944 Jet Black
C9902 White Art	C9912 Sandstone	C9922 Flag Blue	C9927 Brick	C9934 Putty	C9948 Black Belt
C9904 Pure White	C9914 Ginger	C9923 Blue Night	C9928 Cabernet	C9936 Harvest Brown	

C9931 Devonshire    C9935 York    C9938 Kensington    C9940 Gladstone

C5579 Etched Black    C9945 Silver    C9946 Rose    C9947 Spanish Gold

C9910 Antwerpen    C9911 Bruxelles

C69745 Football    C69746 Basketball

## SELECT ULTIBLACKS • 40 x 60 (4 ply)

C89901 Chalk C89904 Pure White C89944 Jet Black C89948 Black Belt

C89940 Gladstone

C85579 Etched Black

## CRESCENT SELECT CONSERVATION SOLIDS • 32 x 40 (4 ply)

C5700 Vivid White C5702 White C5704 Cream C5706 Tan C5712 Cloud Gray  
C5701 Arctic White C5703 Antique White C5705 Buff C5707 Sand C5713 Neutral Gray

C5708 Dark Brown C5710 Dark Gray C5714 Classic Gray  
C5709 Gray C5711 Deep Black

## CRESCENT SELECT CONSERVATION SOLIDS • 40 x 60 (4 ply)

C85700 Vivid White C85702 White C85703 Antique White C85704 Cream C85706 Tan C85712 Cloud Gray C85713 Neutral Gray

C85711 Deep Black C85714 Classic Gray

## CRESCENT SELECT CONSERVATION SOLIDS • 32 x 40 (8 ply)

C25700 Vivid White C25702 White C25703 Antique White C25704 Cream C25706 Tan C25712 Cloud Gray

C25711 Deep Black

## CRESCENT SELECT CONSERVATION SOLIDS • 40 x 60 (8 ply)

C825700 Vivid White C825702 White C825703 Antique White C825704 Cream C825706 Tan C825712 Cloud Gray

C825711 Deep Black

## ACCENTS • 32 x 40 (4 ply)

C9723 Bronze Plated C9724 Silver Plated C9725 Aztec C9726 Outback  
C9727 Gaucho C9728 Safari C9729 Pueblo C9735 Denali  
C9736 Sand Dune C9737 Gobi C9738 Tundra C9739 Mesa

## SELECT SUEDES • 32 x 40 (4 ply)

C5500 Treeline C5503 Berry C5507 Graphite C5510 Red Sky C5515 Thicket C5637 Leaf  
C5501 Brook C5505 Firelight C5508 Cocoa C5511 Light Gray C5633 White C5638 Tile Blue  
C5502 Torrent C5506 Night Sky C5509 Sunrise C5512 Clementine C5636 Purple Torch C5639 Twig

## SELECT SUEDES • 40 x 60 (4 ply)

C85500 Treeline C85502 Torrent C85506 Night Sky C85510 Red Sky C85636 Purple Torch  
C85501 Brook C85503 Berry C85508 Cocoa C85633 White C85638 Tile Blue

## CLASSIC LINENS • 32 x 40 (4 ply)

C5520 Classic Beige C5522 Navy Blue C5527 Deep Red C5532 Vintage Green C5534 Classic Burgundy C5538 Cayenne  
C5521 Noir C5526 English Taupe C5531 Dark Olive C5533 Vintage White C5537 Chestnut

## CLASSIC LINENS • 40 x 60 (4 ply)

C85520 Classic Beige C85521 Noir C85533 Vintage White

## SELECT NATURAL SILKS • 32 x 40 (4 ply)

C5549 Cream C5551 Light Khaki C5554 Truffle C5556 Honey Brown  
C5550 Antique White C5552 Clover C5555 Black Kimono C5557 Tuscan Brown

## VINTAGE LINENS • 32 x 40 (4 ply)

C5558 Vintage Yellow C5559 British Tan C5560 Black Shadow C5561 Sahara Sand C5632 Warm White

## SELECT JUTES • 32 x 40 (4 ply)

C5539 Cream C5540 Barnwood C5541 Navy C5542 Black C5543 Barn Red C5654 Natural

## SELECT JUTES • 40 x 60 (4 ply)

C85539 Cream C85540 Barnwood C85542 Black C85654 Natural

## SHIMMER LINENS • 32 x 40 (4 ply)

C5660 White Shimmer C5661 Ivory Shimmer C5851 Golden Shimmer C5852 Silver Shimmer C5853 Ebony Shimmer

## SHIMMER LINENS • 40 x 60 (4 ply)

C85660 White Shimmer C85661 Ivory Shimmer C85853 Ebony Shimmer

## LUSTER PARCHMENTS • 32 x 40 (4 ply)

C5862 Pewter Parchment C5863 Gold Parchment C5864 Silver Parchment C5865 Snow Parchment C5866 Ivory Parchment C5867 Bronze Parchment

## SELECT BOUCLE • 32 x 40 (4 ply)

C9863 Brittany

## SELECT BOUCLE • 40 x 60 (4 ply)

C89863 Brittany



**SELECT FLANNELS • 32 x 40 (4 Ply)**

C9859 Cambridge	C9861 York	C9865 Kensington	C9869 Red
C9860 Devonshire	C9862 Sandhurst	C9866 Plymouth	

**SELECT FLANNELS • 40 x 60 (4 Ply)**

C89859 Cambridge	C89861 York	C89865 Kensington
C89860 Devonshire	C89862 Sandhurst	C89866 Plymouth

**SELECT FLORENTINES • 32 x 40 (4 Ply)**

C9850 Silver	C9852 Gold	C9855 Spanish Gold
C9851 Gold Nugget	C9854 Rose	C9856 Sun

**SELECT FLORENTINES • 40 x 60 (4 Ply)**

C89850 Silver	C89851 Gold Nugget	C89854 Rose	C89855 Spanish Gold	C89856 Sun
---------------	--------------------	-------------	---------------------	------------

**SELECT BELGIQUES • 32 x 40 (4 Ply)**

C9849 Antwerpen	C9853 Bruxelles
-----------------	-----------------

**SELECT ULTIBLACK BELGIQUES • 32 x 40 (4 Ply)**

C9910 Antwerpen	C9911 Bruxelles
-----------------	-----------------

**SELECT BELGIQUES • 40 x 60 (4 Ply)**

C89849 Antwerpen	C89853 Bruxelles
------------------	------------------

**SELECT METALLICS • 40 x 60 (4 Ply)**

C89521 Gold Rush	C89870 Silver Star
------------------	--------------------

**MOORMAN SUEDES • 32 x 40 (4 Ply)** *High quality sueded fabric on white acid free core.*

C7100 Moutarde	C7114 Carbon Black	C7136 Le Beige	C7159 Cottage Stone	C7181 Sunset	C7193 Tumbleweed
C7101 Perle	C7115 Moka	C7138 Pink	C7160 Ember	C7182 Bronze	C7194 Garnet
C7102 Dune	C7116 Chinese Red	C7139 Anthracite	C7162 Reed	C7183 Moccasin	C7195 Sapphire
C7104 Chamois	C7120 Polaris	C7140 Weesp Blue	C7163 Rattan	C7184 Cinnamon	C7196 Teal
C7105 Dark Rust	C7127 Milkweed	C7141 Platinum	C7164 Meadow	C7185 Chambord	C7199 Spruce
C7106 Antelope	C7128 Off White	C7154 Marigold	C7165 Evergreen	C7186 French Lavender	
C7109 Taupe	C7132 Whisper	C7155 Wildgrass	C7166 Navy	C7187 Celestial	
C7111 Shamrock Green	C7133 Dusty Green	C7156 Summer Sky	C7167 Boulder	C7188 Mercury	
C7112 Bordeaux	C7134 Asparagus	C7157 Cattail	C7168 Graphite	C7190 Olive	
C7113 Marine Blue	C7135 Pine Green	C7158 Storm Gray	C7180 White	C7191 Pfalzgraff	

**MOORMAN SUEDES • 40 x 60 (4 Ply)**

C87100 Moutarde	C87111 Shamrock Green	C87127 Milkweed	C87139 Anthracite	C87166 Navy	C87188 Mercury
C87101 Perle	C87112 Bordeaux	C87128 Off White	C87141 Platinum	C87168 Graphite	C87190 Olive
C87102 Dune	C87113 Marine Blue	C87132 Whisper	C87155 Wildgrass	C87180 White	C87191 Pfalzgraff
C87104 Chamois	C87114 Carbon Black	C87133 Dusty Green	C87157 Cattail	C87182 Bronze	C87193 Tumbleweed
C87105 Dark Rust	C87115 Moka	C87134 Asparagus	C87158 Storm Gray	C87183 Moccasin	C87195 Sapphire
C87106 Antelope	C87116 Chinese Red	C87135 Pine Green	C87163 Rattan	C87184 Cinnamon	C87199 Spruce
C87109 Taupe	C87120 Polaris	C87136 Le Beige	C87164 Meadow	C87185 Chambord	

**MOORMAN BLACK CORE SUEDES • 32 x 40 (4 Ply)**

C67101 Perle	C67106 Antelope	C67112 Bordeaux	C67114 Carbon Black
C67102 Dune	C67111 Shamrock Green	C67113 Marine Blue	C67139 Anthracite

**MOORMAN LINENS • 32 x 40 (4 Ply)**

C7501 Vink Tweed	C7522 Black	C7540 Light Beige	C7551 Flax	C7565 Vintage Ruby	C7580 Burgundy
C7513 Forest Green	C7526 Cream	C7541 Silver Gray	C7553 Edelweiss	C7566 Amethyst Linen	C7581 Jewel Blue
C7517 Dark Rose	C7529 Medium Brown	C7542 Red Carpet	C7554 North Sea	C7567 Ultramarine Blue	C7582 Lotus
C7518 Royal Blue	C7531 Light Gray	C7543 Dark Mauve	C7556 Dutch Chocolate	C7569 Loden Green	C7583 Scroll
C7519 White	C7533 Medium Blue	C7548 Tru Blue	C7557 Topiary	C7571 Delft Brown	C7584 Havana
C7520 Medium Gray	C7536 Blue Green	C7549 Jasper Brown	C7560 Basque	C7572 Worn Gray	C7586 Sumi
C7521 Blue Gray	C7537 Light Moss	C7550 Smokey Hill	C7564 Maroon	C7573 Brindle Brown	C7588 Khaki
					C7597 Off White

**MOORMAN NATURAL LINENS • 32 x 40 (4 Ply)**

C7700 Warm White	C7702 Parchment	C7704 Lagoon	C7706 Harvest
C7701 Canvas	C7703 Willow	C7705 Stone	C7707 Midnight



## MOORMAN LINENS • 40 x 60 (4 Ply)

C87501 Vink Tweed	C87526 Cream	C87548 Tru Blue	C87554 North Sea	C87569 Loden Green	C87581 Jewel Blue
C87513 Forest Green	C87529 Medium Brown	C87549 Jasper Brown	C87556 Dutch Chocolate	C87571 Delft Brown	C87582 Lotus
C87518 Royal Blue	C87540 Light Beige	C87550 Smokey Hill	C87557 Topiary	C87572 Worn Gray	C87586 Sumi
C87519 White	C87541 Silver Gray	C87551 Flax	C87560 Basque	C87573 Brindle Brown	C87597 Off White
C87522 Black	C87542 Red Carpet	C87553 Edelweiss	C87564 Maroon	C87580 Burgundy	

## MOORMAN NATURAL LINENS • 40 x 60 (4 Ply)

C87700 Warm White	C87705 Stone	C87706 Harvest	C87707 Midnight
-------------------	--------------	----------------	-----------------

## MOORMAN SHEER SILKS • 32 x 40 (4 Ply)

C7800 White	C7803 Tan	C7806 Moss	C7809 Blue	C7812 Brown
C7801 Antique White	C7804 Khaki	C7807 Olive	<del>C7810 Maroon</del>	C7813 Deep Brown
C7802 Cream	C7805 Sage	C7808 Green	C7811 Red	C7815 Black

## MOORMAN SHEER SILKS • 40 x 60 (4 Ply)

C87800 White	C87803 Tan	C87809 Blue	C87813 Deep Brown
C87801 Antique White	C87808 Green	C87811 Maroon	C87815 Black

## MOORMAN LEATHER • 32 x 40 (4 Ply)

Black acid free core

C67300 Black Leather	C67307 Van Dyke	C67308 Cordovan	C67309 Tuscan Wine
----------------------	-----------------	-----------------	--------------------

## BRITE CORE MATBOARD • 32 x 40 (4 Ply)

CBR14921 Blue On Black	CBR34921 Red On Black	CBR54921 Orange On Black	CBR74921 Black On Pink
CBR14987 Blue On White	CBR34987 White On Red	CBR54987 Orange On White	CBR74987 White On Pink
CBR24921 Green On Black	CBR44921 Yellow On Black	CBR64921 Purple On Black	CBR84921 Black On Aqua
CBR24987 Green On White	CBR44987 Yellow On White	CBR64987 Purple On White	CBR84987 White On Aqua

## INTERNATIONAL WHITE CORE BASICS • 32 x 40 (4 Ply)

CSRM1000 Pompano Bch White	CSRM1040 Classic Brown	CSRM1096 Sepia	CSRM3370 Cornflower	CSRM3420 All American Red	CSRM972 French Blue
CSRM1001 Moss Point Green	CSRM1042 Williamsburg Red	CSRM3214 Chinese Red	CSRM3372 Black Currant	CSRM3421 Spice	CSRM976 Bar Harbor Gray
CSRM1008 Ivory	CSRM1045 Grass Green	CSRM3290 Snow White	CSRM3400 Baker's White	CSRM3422 Volcano Fire	CSRM977 Newport Blue
CSRM1014 Olde Grey	CSRM1047 Williamsburg Blue	CSRM3291 French Buff	CSRM3401 Chalk	CSRM3423 Jet Black	CSRM978 Congo Green
CSRM1015 Grey Violet	CSRM1051 Olde Tan	CSRM3293 Antique White	CSRM3403 Dove	CSRM3425 York	CSRM979 Dusk
CSRM1016 Concord	CSRM1053 Delft Blue	CSRM3297 Arctic White	CSRM3404 Bone	CSRM902 Yellow	CSRM984 Oak Brown
CSRM1019 Photo Grey	CSRM1054 Baltic Blue	CSRM3300 Alabaster	CSRM3406 Tawny	CSRM915 Fog	CSRM985 Pyro Brown
CSRM1023 Crimson	CSRM1057 Redwood	CSRM3319 Topaz	CSRM3407 Putty	CSRM918 Very White	CSRM986 Tampico Brown
CSRM1025 Medium Gray	CSRM1073 Biscay Blue	CSRM3325 Mandarin	CSRM3409 Fawn	CSRM919 Ivy Green	CSRM987 Palm Beach White
CSRM1027 Silver Gray	CSRM1076 Las Cruces Purple	CSRM3326 Lapis	CSRM3410 Ginger	CSRM921 Smooth Black	CSRM988 Williamsburg Green
CSRM1028 Spice Ivory	CSRM1081 Volcano Blue	CSRM3331 Sage	CSRM3412 Mocha Green	CSRM924 Dark Gray	CSRM989 Raven Black
CSRM1029 Wheat	CSRM1082 Marine Blue	CSRM3333 Black Watch	CSRM3413 Forest Green	CSRM934 Pearl	CSRM994 Chamois Gold
CSRM1032 Dark Olive	CSRM1084 Avocado	CSRM3364 Green Apple	CSRM3414 Sierra Olive	CSRM939 Dark Green	CSRM997 Sable
CSRM1038 Maroon	CSRM1088 Mist	CSRM3368 Sunset Clay	CSRM3417 Flag Blue	CSRM948 Sand	
CSRM1039 Auburn	CSRM1089 Sauterne	CSRM3369 Sheer Blue	CSRM3418 Cabernet	CSRM961 Cream	
CSRM968 Old Gold	CSRM969 Silver				

## INTERNATIONAL WHITE CORE BASICS • 40 x 60 (4 Ply)

CSRM8921 Smooth Black	SRM81088 Mist	SRM83293 Antique White	CSRM8987 Palm Beach White	SRM83403 Dove	SRM83417 Flag Blue
CSRM8988 Williamsburg Green	SRM81027 Silver Gray	CSRM8977 Newport Blue	SRM83400 Baker's White	SRM83404 Bone	SRM83420 All-American Red
CSRM8989 Raven Black	SRM81028 Spice Ivory	SRM83297 Arctic White	SRM83401 Chalk	SRM83411 Green Mist	SRM83423 Jet Black
SRM83430 Chaps	SRM83437 Antwerpen				
CSRM8968 Old Gold					

## FAUX MARBLE (INTERNATIONAL WHITE CORE) • 32 x 40 (4 Ply)

C4400 Light Gray	C4404 Black
------------------	-------------

## FAUX MARBLE METALLIC (INTERNATIONAL WHITE CORE) • 32 x 40 (4 Ply)

C4444 Black Gold
------------------

## CLASSICS (INTERNATIONAL WHITE CORE) • 32 x 40 (4 Ply)

Faux Leather				
CSRM3426 Rawhide	CSRM3427 Buckskin	CSRM3428 New Stetson	CSRM3429 Saddle	CSRM3430 Chaps

Library Leather

CSRM3431 Chaucer Brown	CSRM3433 Hawthorne Red	CSRM3435 Kerouac Black
CSRM3432 Longfellow Green	CSRM3434 Hemingway Blue	

Belgiques

CSRM3437 Antwerpen	CSRM3438 Bruxelles
--------------------	--------------------

**CRESCENT RAG MATS • 32 x 40 (4 ply)**

C1420 Cloud	C1548 Ashen	C1577 Raven Black	C1612 True Red	C1646 Sky Blue	C1678 French Jonquil
C1421 Satin	C1550 Newport Blue	C1578 Williamsburg Blue	C1613 Very White	C1647 Patriot Blue	C1679 Wild Basil
C1423 Cloth	C1551 Storm Blue	C1582 Antique Buff	C1616 New Clay	C1648 Ultramarine	C1680 Micro Mint
C1427 Chive	C1552 Biscay Blue	C1583 Olde Tan	C1618 Pottery	C1649 Naples Yellow	C1681 Celery Seed
C1429 Lake	C1553 Bar Harbor Gray	C1584 Nutmeg	C1619 Topaz	C1650 Warm White	C1682 Clearwater
C1431 Ink Blue	C1554 Williamsburg Green	C1586 Light Mauve	C1624 Periwinkle Blue	C1651 Flaxen	C1683 Sauterne
C1433 Shade	C1555 Avocado	C1588 Ivory	C1625 Crimson	C1652 Auburn	C1684 Optic White
C1512 Tuscany Blue	C1558 Russet	C1592 Ocean Mist	C1626 Lapis	C1653 Maroon	C1685 Moonlight
C1513 Calypso Blue	C1559 Redwood	C1593 Sea Shell	C1627 Cerise	C1654 Laurel Green	C1686 Cotton White
C1514 Royal Orchid	C1560 Rust	C1594 Olde Grey	C1629 Taos	C1656 Country Blue	C1687 Eiderdown
C1516 Serengeti	C1561 Sepia	C1595 Grey Violet	C1631 Sage	C1659 Blue Belle	C1688 Whisper White
C1517 Ra	C1562 Sable	C1597 Silver Leaf	C1632 Tea Rose	C1660 Imperial Blue	C1689 Sandstorm
C1518 Wasabi	C1563 Tampico Brown	C1599 Dusty Blue	C1633 Black Watch	C1661 Majestic Purple	C1690 Olive Bronze
C1519 Gecko	C1564 Oak Brown	C1600 Medium Gray	C1634 Fog	C1662 Espresso	C1691 Filbert
C1521 Amazon	C1565 Suntan	C1601 Rose Gray	C1636 Alabaster	C1663 Chamois Gold	C1692 Cashew
C1522 Grecian Olive	C1566 Sandstone	C1602 Silver Gray	C1637 English Stone	C1664 Script White	C1693 Sherwood Green
C1523 Outback Haze	C1567 Sand	C1603 Spice Ivory	C1638 Tapestry	C1665 Barely Blue	C1768 Old Gold
C1524 Bali Sand	C1570 French Buff	C1604 Wheat	C1639 Amethyst	C1666 Sheer Blue	
C1525 Moroccan Spice	C1571 Palm Beach White	C1605 Pastel Pink	C1640 Purple Wildflower	C1668 River Rock	
C1526 Tandoori	C1572 Mist	C1606 Off White	C1641 Malachite	C1670 French Lilac	
C1528 Napa Wine	C1573 Pearl	C1607 Brite White	C1642 Aruba	C1672 Barely Pink	
C1545 Light Umbria	C1574 Dawn Gray	C1608 Cream	C1643 Garnet	C1673 Really Red	
C1546 Dark Olive	C1575 Copley Gray	C1609 Antique White	C1644 Azalea	C1674 Venetian Red	
C1547 Brighton	C1576 Dark Gray	C1610 White	C1645 Cherub Pink	C1675 Sunset Clay	

**CRESCENT RAG MATS • 40 x 60 (4 ply)**

<del>C81420 Cloud</del>	C81577 Raven Black	C81607 Brite White	C81626 Lapis	<del>C81687 Eiderdown</del>
C81516 Serengeti	C81578 Williamsburg Blue	C81608 Cream	C81631 Sage	C81688 Whisper White
C81550 Newport Blue	C81583 Olde Tan	C81609 Antique White	<del>C81633 Black Watch</del>	C81689 Sandstorm
C81554 Williamsburg Green	C81584 Nutmeg	C81610 White	C81647 Patriot Blue	
C81562 Sable	C81588 Ivory	C81612 True Red	C81653 Maroon	
C81571 Palm Beach White	C81602 Silver Gray	C81613 Very White	<del>C81655 Alpine Green</del>	
C81572 Mist	C81603 Spice Ivory	C81619 Topaz	C81664 Script White	
C81576 Dark Gray	C81606 Off White	C81625 Crimson	C81686 Cotton White	

**CRESCENT ANTIQUARIAN RAG MATS • 32 x 40 (4 ply Cream Rag Core)**

C1702 Moss	C1706 Rubia	C1711 Black Walnut	C1716 Brittany	C1723 Lapis
C1703 Foxhunt Green	C1708 Hazelnut	C1713 Stonehenge	C1718 Grayling	
C1704 Ashen	C1709 Light Umbria	C1714 Flaxen	C1721 Black	
C1705 Antique Ivory	C1710 Dark Umbria	C1715 Antique Lace	C1722 Dark Olive	

**CRESCENT RAG MAT NOIR • 32 x 40 (4 ply Black Rag Core)**

C61553 Bar Harbor Gray	C61603 Spice Ivory	C61684 Optic White	C61704 Ashen
C61571 Palm Beach White	C61610 White	C61689 Sandstorm	
C61574 Dawn Gray	C61662 Espresso	C61690 Olive Bronze	

**MICHAEL GRAVES COLLECTION • 32 x 40 (4 ply)**

C1400 White Gold	C1401 Gold	C1402 Copper	C1403 Silver	C1404 Graphite
------------------	------------	--------------	--------------	----------------





## CRESCENT RAG MAT MUSEUM SOLIDS • 32 x 40

C1100 Archival Mist	C1105 Desert Sand	C1117 Gray	C1125 Shetland	C1133 Briar	C1174 Beige
C1101 Neutral Gray	C1106 Antique Gray	<del>C1120 Brighton</del>	C1127 Sprout	C1134 Bramble	C1175 Clay
C1102 Vintage Gray	C1108 Dark Cream	C1121 Inverness	C1128 Shoreline	C1173 Soft Cream	C1176 Suntan
C1104 Antique Tan	C1114 Almond	C1122 Stratford	C1129 Bluff		
C1112 Soft White	C1126 Sand Dollar	C1170 Cool White	C1171 Silk		
C1115 Black	C1136 Loam	C1178 Fern			
C1123 New Castle	C1137 Fieldstone	C1179 Williamsburg Green			
C1135 Hedge	C1177 Brownstone	C1184 Sable			
C2255 Cream	C2297 Unbuffered Cream				
C2296 Unbuffered Optic Black					
C2253 White	C2259 Antique White	C2298 Unbuffered Antique White	C2299 Unbuffered White		

**6 PLY**  
C1536 White

**8 PLY**  
C21112 Soft White    C21126 Sand Dollar    C2238 White    C2239 Antique White

C21104 Antique Tan    C21106 Antique Gray    C22255 Cream

C21115 Black

## CRESCENT RAG MAT MUSEUM SOLIDS • 40 x 60

C2260 Antique White	C81104 Antique Tan	C81106 Antique Gray	C81126 Sand Dollar
C2262 White	C81105 Desert Sand	C81112 Soft White	
C2261 Cream	C81114 Almond	C81173 Soft Cream	C81121 Inverness
C81115 Black			

**8 PLY**  
C821112 Soft White    C82239 Antique White    C2268 White

C821115 Black

## CRESCENT RAG MAT MUSEUM SOLIDS

**1 PLY Museum Barrier Paper 32 x 40**  
C1515 Off White (.015 Thick)

**2 PLY Rag Museum Boards 32 x 40**  
C1150 White    C1152 Cream    C1157 Antique White

**2 PLY Rag Museum Boards 40 x 60**  
C81150 White

**4 PLY Duplex Museum Boards 32 x 40 (different color on each side)**  
C1530 Antique White/White    C1531 Off White/Cream

**4 PLY Rag Museum Boards 32 x 40**  
C1153 White    C1155 Cream    C1159 Antique White

**4 PLY Rag Museum Boards 40 x 60**  
C1161 Cream    C1162 White

**4 PLY Rag Museum Boards 48 x 60**  
C1163 White    C1169 Antique White

## CRESCENT RAG MAT MUSEUM SOLIDS • (Oversized)

C2263 White 48 x 72	
C2273 White 48 x 96	C2279 Antique White 48 x 96
C2275 Black 48 x 96	
C2283 White 60 x 104	C2289 Antique White 60 x 104

**CORDED SILKS • 32 x 40 (4 Ply)**

C5859 Crystal      C5860 Sandcastle      C5861 Amber

**CORDED SILKS • 40 x 60 (4 Ply)**

C85859 Crystal      C85860 Sandcastle      C85861 Amber

**GOSSAMER SILKS • 32 x 40 (4 Ply)**

C5854 Coffee      C5855 Raffia      C5856 Glacier Gray      C5857 Peppercorn      C5858 Dusty Plum

**GOSSAMER SILKS • 40 x 60 (4 Ply)**

C85854 Coffee      C85855 Raffia      C85857 Peppercorn

**SHIMMER WOVENS • 32 x 40 (4 Ply) • New!**

C7310 Icicle      C7311 Golden Moon      C7312 Mint Julep      C7313 Praline      C7314 Stardust      C7315 Blue Galaxy

**CRESCENT COUTURE • 32 x 40 • New!**

C1300 Spun Tungsten      C1301 Spun Platinum      C1302 Silver Jute      C1303 Black Lacquer      C1304 Gray Pebbles      C1305 Black Pebbles

**CRESCENT COUTURE • 32 x 40 • New!**

C1306 Molten Gold      C1308 Urban Gray      C1309 Silver Birch      C1310 Aged Copper      C1311 Mahogany Leather      C1312 Russet Leather

**CRESCENT COUTURE • 32 x 40 • New!**

C1313 Silver Leaf      C1314 Gold Leaf

**Decorative Mounting Boards**

A complete range of foam and mounting boards for any non-conservation mounting need. Crescent decorative mounting boards are warp resistant, cut easily and come in a full range of sizes and thicknesses.

Perfect for all general mounting and display purposes.

**Conservation Mounting Boards**

When long-term protection of art is necessary, use Crescent's line of conservation quality mounting boards. Designed to meet all conservation standards for mat and mounting boards as set by F.A.C.T.S. and F.A.T.G., Crescent acid-free conservation mounting boards are warp resistant, cut easily and come in a full range of sizes and thicknesses.

**CRESCENT ACID FREE MOUNTING BOARDS • 32 x 40**

*Acid free pulp core & surface papers*

CAFX Acid Free X Board (0.50 Thick)

CAF3X Acid Free 3X Board (0.90 Thick)

**CRESCENT WHITE MOUNTING BOARDS**

CX.9 "X" Mounting Board (0.48 Thick) 28x44

CX.12 "X" Mounting Board (0.48 Thick) 32x40

C3X.12 "3X" Mounting Board (0.90 Thick) 32x40

**CRESCENT WHITE MOUNTING BOARDS • 40 x 60**

CS "S" Mounting Board (0.48 Thick)

CO "O" Mounting Board (0.90 Thick)

**CRESCENT ULTRABLACK MOUNTING BOARD • 32 x 40**

C8 UltraBlack 8 Solid Black Double Sided mount board

**CRESCENT PERFECT MOUNT ACID FREE CORE & PAPER SHADE • 32 x 40**

CPSX PSX Perfect Mount ST (.050-.055)

CPS3X PS3X Perfect Mount DT (.085-.090)

CPSFC PSFC Perfect Mount Sheets 3/16" Foam Center

**CRESCENT ILLUSTRATION BOARDS**

C300 30x40 Cold Press Illustration Board (.05-.06) Medium Weight

C110.6 20x30 Cold Press Illustration Board (.085-.095) Heavy Weight

**CRESCENT PRESENTATION BOARDS**

C601 14-ply Poster Board 28x44 Satin White

C11W Needleart Mount Board 32x40 (.188 triple-thick white)

CPBFC Black Perfect Mount Foam Board (3/16") 32x40



### Peterboro Matboards

Peterboro Matboards provides custom framers with matboards of superior quality at unparalleled value. Peterboro sets the standard for quality by using only premium grade materials and then individually inspecting each matboard. Product range includes Museum (100% cotton), Conservation alpha cellulose and cotton, Premium Whitecore, Blackcore, Creamcore, Silks, Linens, Weaves and Conservation Suede matboards.

### PETERBORO REGULAR

#### Peterboro Regular Matboards

Peterboro Regular is a smooth cutting cream core matboard. Available in a wide range of colors and textures, Peterboro Regular is suitable for decorative, economical framing applications.

- Buffered to an alkaline pH
- Over 70 % of the surface papers are conservation grade, bleed and fade resistant
- Conservation grade backing paper
- Pulp core

Recommended For:

- Decorative framing and general-presentations
- Open end reproductions
- Posters and decorative art

### PETERBORO WHITE CORE

#### Peterboro White Core Matboards

This premium Whitecore matboard is designed for customers who want the decorative impact of a bright white bevel but don't require conservation protection.

- Brite white bleached alpha cellulose core
- Buffered to an alkaline pH
- 80 % of the surface papers are conservation grade, bleed and fade resistant
- Conservation grade backing paper
- Suitable for use in non conservation, decorative framing applications

Recommended For:

- Decorative framing and general presentations
- Open end reproductions
- Posters and decorative art

### PETERBORO BLACK CORE

#### Peterboro Black Core Matboards

Peterboro Blackcore is a high-quality matboard made with a black center that acts as an added element of design. Blackcore matboards can be used to highlight v-grooves, photographs and works of art without the use of a double mat.

- Buffered to an alkaline pH, rich, even, bleed resistant black core
- Easy to cut
- Conservation grade grey backing paper reduces rub off

Recommended For:

- Decorative framing and general presentations
- Open end reproductions
- Posters and decorative art



PETERBORO  
CONSERVATION

**Peterboro Conservation Matboards**

Peterboro Conservation matboards are constructed in accordance with the international standards as defined by the Fine Art Trade Guild of London England.



- White high alpha cellulose core
- Contains no acid, lignin or ground wood
- Fade and bleed resistant surface papers
- Buffered to an alkaline pH
- Contains no optical brighteners
- Suitable for use in all conservation framing applications

Recommended For:

- Fine Art Prints
- Limited Editions
- Valuable Documents
- Photography



**Fine Art Trade Guild & Fine Art Care & Treatment Standards**

Over 100 years, the **Fine Art Trade Guild (FATG)** is one of the oldest international associations for the art and framing industry that sets and maintains standards with which the trade and its customers can be secure. Established in 1994, **FACTS** evolved from the ever-increasing need for information about the preservation of artwork and keepsakes. Standards are reviewed regularly to include new research and are recognized by the Professional Picture Framers Association (PPFA).



**Peterboro Museum Matboards**



Peterboro Museum matboards are constructed from the finest 100% cotton fiber and are constructed in accordance with the international standards as defined by the Fine Art Trade Guild of London England.

These 100% Cotton boards are of the finest quality as they maintain the purest form of natural cellulose, require little processing and maintain a history of performance. Accordingly, every board of this premium line adheres to both FACTS and the Fine Art Trade Guild's stringent specifications for Museum Matboards.

A 100% cotton board provides the comfort and assurance that matted artwork will be preserved for future generations and at present it is the top choice of framers, museums, and conservators for the mounting, matting, and preservation of fine prints and documents. Peterboro Museum allows framers to uphold the cotton tradition to its fullest while enhancing and protecting your artwork for years to come.

- 100% cotton fiber, solid color throughout
- Traditional ply construction, buffered with calcium carbonate
- Naturally acid and lignin free
- Suitable for use in Museum level framing applications
- Facing papers exceed minimum standards for fade and bleed as set by F.A.C.T.S. and F.A.T.G.
- pH 8.5 - 9.5, buffered with calcium carbonate to an alkaline reserve of 3 -5%
- 4 ply and 8 ply thicknesses. (Consult matboard specifier)
- Meets Museum Standards as set by F.A.C.T.S. and F.A.T.G.

**Peterboro Museum board is recommended for:**

- Valuable works of original art
- Surface papers are pigmented for fade and bleed resistance.
- Items of historical importance
- Treasured heirlooms



PETERBORO  
DESIGNER  
FABRICS

**Peterboro Designer Fabrics**

The sophistication of silks, the timeless elegance of linens and the classic look of a weave allow for new dimensions in style, creativity and affordability. Easy to cut at an exceptional value.

- White high alpha cellulose conservation core
- Free of acid, lignin and ground wood
- Buffered to an alkaline pH
- 100% virgin fiber conservation backing
- Contains no optical brighteners (Excluding Silk DF940 and Linen DF945)
- Suitable for use in all conservation framing applications

PETERBORO  
DESIGNER  
SUEDE

**Peterboro Designer Suede**

The attractive changes in color and texture, characteristic of suede, add a new dimension to matting. Whether it is used in shadowboxes, photos, art, or precious heirlooms, suede will always add a touch of elegance to any frame.

- A Conservation quality designer suede
- Vibrant surface colors with a dense luxurious flock
- Buffered to an alkaline pH, extra thick white bevel
- Suitable for all conservation framing applications

PETERBORO  
MOUNT BOARDS

**Peterboro Mount Boards**

Mount Boards come in a variety of specifications to meet your everyday needs.

**Grey Unlined Mountboards:**

These boards are 100% buffered and come in both a 40pt and 80pt thickness.

Single Thick .040" : 28" x 44", 32" x 40", & 40" x 60"

Double Thick .080" : 28" x 44", 32" x 40", & 40" x 60"

**Paper Lined Mountboards**

These boards are lined on both sides and buffered.

Black paper lined .050" : 28" x 44"

White - Two Sides .055" : 28" x 44", 32" x 40", 40" x 60"

White - Two Sides .095" : 28" x 44", 32" x 40"

## Regular Core Mat Board • 32 x 40 (4 Ply)

R101-109 Smooth White & Blk	R132 Peach	R319 Dark Blue	R345 Rust	R365 Moss Green	R386 Dark Black
R111 Dijon	R133 Lavender	R320 Crimson	R346 Storm Grey	R366 Cadet Grey	R388 Maize
R113 Citrus	R150-153 White & Cream	R321 Crystal White	R348 Powder Blue	R368 Blueberry	R389 Porpoise
R115 Talc	R160 White Eggshell	R322 Vanilla	R349 Off White	R369 Sparkling White	R391 Riviera Blue
R117 Thistle	R161 Lt. Cream Eggshell	R323 Atlantic	R351 Sunflower	R370 White	R392 Antique
R118 Lichen	R303 Goldenrod	R327 Sapphire	R352 Snow White	R371 Agate Grey	R394 Coral
R119 Balsam	R305 Evergreen	R331 Pumice	R353 Pale Grey	R372 Chalk	R395 Ivory
R120 Fathom	R306 Cardinal Red	R332 Flax	R354 Nickel	R373 Venetian Blue	R396 Pale Blue
R121 Peregrine	R307 Mist	R334 Raspberry	R356 Mocha	R375 Chinese Red	R399 Burnt Sienna
R122 Azure	R308 Bluejay	R335 Sand	R357 Silver Grey	R376 Silver Pine	R401 Feather Grey
R123 Pacific	R309 Brite White	R338 Haze	R358 Dark Grey	R377 Maroon	R402 Charcoal Grey
R124 Sahara	R310 Winter White	R339 Cocoa	R359 Claret	R378 Juniper	R404 Teakwood Black
R125 Sierra	R311 Silver White	R340 Spring Green	R360 Soft Grey	R379 Soft White	
R126 Saffron	R312 Burgundy	R341 Pecan	R361 Limoges	R380 Beaver Brown	
R127 Ash	R314 Forest Green	R342 Cognac	R362 Cedar	R381 Bisque	
R128 Smoke	R315 Terrace	R343 Coffee	R363 Taupe	R382 Plum	
R131 Apple Red	R317 Cirrus	R344 Rosewood	R364 Art Brown	R385 Trail	

## Regular Core Designer Mat Board • 32 x 40 (4 Ply)

R1419 Black Leather      R1411 Lace      R1412 Khaki

R1420 Onyx

## Regular Core Textured & Embossed Mat Board • 32 x 40 (4 Ply)

R1304 Teakwood Black Linen      R1369 Linen Sparkling White      R1353 Linen India Tint  
 R1350 Linen White      R251-259 Pebbled Wht./Light Cream

R1401-14 Pebbled White/Black

## Regular Core Foils Mat Board • 32 x 40

R781 Smooth Gold      R782 Light Gold      R791 Mercury      R793 Light Silver

R792 0.055" Gold Foil

R762 0.030" Gold Foil

## Regular Core Giant Mat Board • 40 x 60 (4 Ply)

RG6117 Thistle      RG6364 Art Brown      RG6373 Venetian Blue  
 RG6312 Burgundy      RG6365 Moss Green  
 RG6314 Forest Green      RG6368 Blueberry

RG6150-6 White & Cream      RG6370 White  
 RG6369 Sparkling White      RG6404 Teakwood Black

## Whitcore Foils Mat Board • 32 x 40

W781 Smooth Gold      W791 Mercury      W1795 Spun Gold  
 W782 Light Gold      W792 0.055" Gold Foil      W1797 Gold Splash  
 W793 Light Silver      W1794 Silver Splash      W5046 Aztec Gold

**Whitecore Mat Board • 32 x 40 (4 Ply)**

• High Alpha Cellulose Bright White Core • Made with Conservation Quality backing paper • Buffered with calcium carbonate

W1000 Digital White	W5022 Burnt Orange	W5051 Overcast	W538 Haze	W568 Blueberry	W598 Wheat
W101 Smooth White	W5023 Royal Blue	W5052 Flint	W539 Cocoa	W569 Sparkling White	W599 Burnt Sienna
W101-109 Smooth White & Black	W5024 Real Red	W5053 Sandstorm	W540 Spring Green	W570 White	W600 Stone
W109 Black	W5025 Blue Stone	W505 Evergreen	W541 Pecan	W571 Agate Grey	W601 Feather Grey
W1501 Pebbled White	W5026 Teal	W506 Cardinal Red	W542 Cognac	W572 Chalk	W602 Charcoal Grey
W1504 Black Linen	W5027 Wicker	W507 Mist	W543 Coffee	W573 Venetian Blue	W604 Teakwood Black
W1509 Pebbled Black	W5028 Dusty Cream	W508 Bluejay	W544 Rosewood	W575 Chinese Red	W611 Dijon
W1550 White Linen	W5029 Buff	W509 Brite White	W545 Rust	W576 Silver Pine	W613 Citrus
W5000 Antique Rose	W503 Goldenrod	W510 Winter White	W546 Storm Grey	W577 Maroon	W615 Talc
W5001 Oatmeal	W5030 Clover	W511 Silver White	W548 Powder Blue	W578 Juniper	W617 Thistle
W5002 Cashew	W5031 Midnight Black	W512 Burgundy	W549 Off White	W579 Soft White	W618 Lichen
W5003 Caribbean Blue	W5032 Cobblestone	W514 Forest Green	W550 Georgian Blue	W580 Beaver Brown	W619 Balsam
W5004 Antique Blue	W5033 Medium Black	W515 Terrace	W551 Sunflower	W581 Bisque	W620 Fathom
W5005 Pink	W5034 Wine	W516 Putty	W552 Snow White	W582 Plum	W621 Peregrine
W5006 Olive	W5035 Inspired White	W517 Cirrus	W553 Pale Grey	W583 Bamboo	W622 Azure
W5007 Ice Pink	W5036 Siberian White	W518 Silica	W554 Nickel	W584 Canyon	W623 Pacific
W5008 Blush	W5037 Brite Red	W519 Dark Blue	W555 Misty Grey	W585 Trail	W624 Sahara
W5009 Celery	W5038 Java	W520 Crimson	W556 Mocha	W586 Dark Black	W625 Sierra
W5010 Soft Mauve	W5039 Blue Heron	W521 Crystal White	W557 Silver Grey	W587 Dune	W626 Saffron
W5011 Victorian Rose	W5040 London Grey	W522 Vanilla	W558 Dark Grey	W588 Maize	W627 Ash
W5012 Beige	W5041 Egrit	W523 Atlantic	W559 Claret	W589 Porpoise	W628 Smoke
W5013 Pearl	W5042 Pumpkin	W526 Tan	W560 Soft Grey	W590 Willow	W630 Cinnamon
W5014 Glacier White	W5043 Midnight Blue	W527 Sapphire	W561 Limoges	W591 Riviera Blue	W631 Apple Red
W5015 African Violet	W5044 Shamrock	W528 Aspen	W562 Cedar	W592 Antique	W632 Peach
W5016 Dark Almond	W5045 Persimmon	W529 Jurassic	W563 Taupe	W593 Classic Parchment	W633 Lavender
W5017 Ginger	W5047 Lemon	W531 Pumice	W564 Art Brown	W594 Coral	W660 White Eggshell
W5019 Ocean Grey	W5048 Fern	W532 Flax	W565 Moss Green	W595 Ivory	
W5020 Tangerine	W5049 Spruce	W534 Raspberry	W566 Cadet Grey	W596 Pale Blue	
W5021 White Ice	W5050 Cloudy Grey	W535 Sand	W567 Clay	W597 Wattle	

**Whitecore Designer Mat Board • 32 x 40 (4 Ply)**

W1420 Onyx	W1796 Copper
------------	--------------

**Whitecore Double Thick Mat Board • 32 x 40**

W521-DT Crystal White	W569-DT Sparkling White	W572-DT Chalk	W604-DT Teakwood Black
-----------------------	-------------------------	---------------	------------------------

**Whitecore Giant Mat Board • 40 x 60**

WG61000 Digital White	WG65023 Royal Blue	WG6510 Winter White	WG6558 Dark Grey	WG6575 Chinese Red	WG6624 Sahara
WG65001 Oatmeal	WG65028 Dusty Cream	WG6515 Terrace	WG6564 Art Brown	WG6578 Juniper	
WG65002 Cashew	WG65031 Midnight Black	WG6519 Dark Blue	WG6565 Moss Green	WG6579 Soft White	
WG65010 Soft Mauve	WG65034 Wine	WG6521 Crystal White	WG6568 Blueberry	WG6580 Beaver Brown	
WG65012 Beige	WG65035 Inspired White	WG6534 Raspberry	WG6569 Sparkling White	WG6586 Dark Black	
WG65013 Pearl	WG65037 Brite Red	WG6538 Haze	WG6570 White	WG6597 Wattle	
WG65014 Glacier White	WG65040 London Grey	WG6549 Off White	WG6572 Chalk	WG6604 Teakwood Black	
WG65021 White Ice	WG6506 Cardinal Red	WG6552 Snow	WG6573 Venetian Blue	WG6621 Peregrine	

WG6791 Mercury	WG6781 Smooth Gold
----------------	--------------------

**Whitecore Double Thick Giant Mat Board • 40 x 60**

WG6521-D Crystal White	WG6569-D Sparkling White	WG6604-D Teakwood Black
------------------------	--------------------------	-------------------------

**Whitecore Mat Board • 40 x 60 (4 Ply)**

WG61420 Onyx
--------------

**Black Core Mat Board • 32 x 40 (4 Ply)**

B118 Lichen	B3023 Royal Blue	B315 Terrace	B370 White	B389 Porpoise	PB791 Mercury
B3001 Oatmeal	B3024 Real Red	B353 Pale Grey	B372 Chalk	B404 Teakwood Black	
B3021 White Ice	B3025 Blue Stone	B368 Blueberry	B377 Maroon	B781 Gold	
B3022 Burnt Orange	B305 Evergreen	B369 Sparkling	B378 Juniper	PB311 Silver White	

B3020 Onyx
------------



## Black Core Giant Mat Board - 40 x 60 (4 Ply)

BG6369 Sparkling White	BG6372 Chalk	BG6404 Teakwood Black
BG6370 White	BG6378 Juniper	BG6781 Gold

## Conservation Mat Board - 32 x 40 (4 Ply)

• White high alpha cellulose core that is free of acid, lignin, and ground wood • Fade and bleed resistant surface papers • Buffered to an alkaline pH  
 • Contains no optical brighteners • Meets all Fine Art Trade Guild and Fine Art Care & Treatment standards

A109 TV Black	A4004 Antique Blue	A407 Mist	A4422 Burnt Orange	A446 Storm Grey	A479 Soft White
A150-153 White Wash / Cream	A4005 Pink	A408 Bluejay	A4423 Royal Blue	A448 Powder Blue	A480 Beaver Brown
A211 Dijon	A4006 Olive	A409 Brite White	A4424 Real Red	A449 Off White	A481 Bisque
A215 Talc	A4007 Ice Pink	A410 Winter White	A4425 Blue Stone	A451 Sunflower	A482 Plum
A217 Thistle	A4008 Blush	A411 Silver White	A443 Coffee	A452 Snow	A485 Trail
A218 Lichen	A4009 Celery	A412 Burgundy	A4435 Inspired White	A453 Pale Grey	A486 Dark Black
A219 Balsam	A4010 Soft Mauve	A414 Forest Green	A4436 Siberian White	A454 Nickel	A488 Maize
A220 Fathom	A4011 Victorian Rose	A415 Terrace	A4437 Brite Red	A456 Mocha	A489 Porpoise
A221 Peregrine	A4012 Beige	A416 Putty	A4438 Java	A457 Silver Grey	A491 Riviera Blue
A222 Azure	A4013 Pearl	A417 Cirrus	A4439 Blue Heron	A458 Dark Grey	A492 Antique
A223 Pacific	A4014 Glacier White	A422 Vanilla	A444 Rosewood	A460 Soft Grey	A494 Coral
A224 Sahara	A4015 African Violet	A423 Atlantic	A4440 London Grey	A461 Limoges	A495 Ivory
A225 Sierra	A4016 Dark Almond	A426 Tan	A4441 Egrit	A462 Cedar	A496 Pale Blue
A226 Saffron	A4017 Ginger	A427 Sapphire	A4442 Pumpkin	A463 Taupe	A497 Wattle
A227 Ash	A4019 Ocean Grey	A428 Aspen	A4443 Midnight Blue	A464 Art Brown	A499 Burnt Sienna
A228 Smoke	A4020 Tangerine	A431 Pumice	A4444 Shamrock	A465 Moss Green	A501 Feather Grey
A230 Cinnamon	A4026 Teal	A432 Flax	A4445 Persimmon	A466 Cadet Grey	A502 Charcoal Grey
A231 Apple Red	A4027 Wicker	A434 Raspberry	A4447 Lemon	A468 Blueberry	A504 Teakwood Black
A232 Peach	A4028 Dusty Cream	A435 Sand	A4448 Fern	A470 White	A819 Dark Blue
A233 Lavender	A4029 Buff	A438 Haze	A4449 Spruce	A471 Agate Grey	AC4881 Canvas White
A4000 Antique Rose	A403 Goldenrod	A440 Spring Green	A4450 Cloud Grey	A472 Chalk	AS421 Crystal White
A4001 Oatmeal	A4030 Clover	A441 Pecan	A4452 Overcast	A473 Venetian Blue	AS4471 Digital White
A4002 Cashew	A405 Evergreen	A442 Cognac	A4453 Sandstorm	A476 Silver Pine	
A4003 Caribbean Blue	A406 Cardinal Red	A4421 White Ice	A445 Rust	A478 Juniper	

A4446 Aztec Gold	A4793 Light Silver
A4781 Smooth Gold	A4794 Silver Splash
A4782 Light Gold	A4795 Spun Gold
A4791 Mercury	A4797 Gold Splash

A4420 Onyx	A4796 Copper
------------	--------------

## Conservation Embossed Mat Board - 32 x 40 (4 Ply)

A1304 Black Linen	A1401 Pebbled White	A160 White Eggshell
A1350 Linen White	A1409 Pebbled Black	A161 Light Cream Eggshell

## Conservation Double Thick Mat Board - 32 x 40

A452-DT Snow	A472-DT Chalk
A470-DT White	A504-DT Teakwood Black

## Conservation Double Thick Giant Mat Board - 40 x 60

AG6452-D Snow	AG6504-D Teakwood Black
---------------	-------------------------

## Conservation Giant Mat Board - 40 x 60 (4 Ply)

AG6150-6 White Wash/Cream	AG64010 Soft Mauve	AG6412 Burgundy	AG64437 Brite Red	AG6468 Blueberry	AG6819 Dark Blue
AG6217 Thistle	AG64012 Beige	AG6414 Forest Green	AG64440 London Grey	AG6470 White	AC64881 Canvas White
AG6221 Peregrine	AG64013 Pearl	AG6415 Terrace	AG6449 Off White	AG6472 Chalk	ASG6421 Crystal White
AG6224 Sahara	AG64014 Glacier White	AG6438 Haze	AG6452 Snow	AG6473 Venetian Blue	ASG64471 Digital White
AG6231 Apple Red	AG64028 Dusty Cream	AG64421 White Ice	AG6458 Dark Grey	AG6479 Soft White	
AG64001 Oatmeal	AG6406 Cardinal Red	AG64423 Royal Blue	AG6464 Art Brown	AG6486 Dark Black	
AG64002 Cashew	AG6410 Winter White	AG64435 Inspired White	AG6465 Moss Green	AG6504 Teakwood Black	

AG6781 Smooth Gold	AG6791 Mercury
--------------------	----------------

AG64420 Onyx
--------------

**Designer Silkscreen Mat Board • 32 x 40 (4 Ply)**

- Printed with lightfast bleed-resistant inks
- High quality white core
- Smooth bright white bevel
- All parts acid free and buffered
- Buffered to a pH of 8.0 to 9.5

DSK0101 Fresco Chalk	DSK0201 Venetian Plaster Ivory	DSK0301 Travertine Chalk
DSK0102 Fresco Vanilla	DSK0202 Venetian Plaster Talc	DSK0302 Travertine Vanilla
DSK0103 Fresco Haze	DSK0203 Venetian Plaster Powder	DSK0303 Travertine Haze
DSK0104 Fresco Maize	DSK0204 Venetian Plaster Sierra	DSK0304 Travertine Bisque
DSK0105 Fresco Nickel	DSK0205 Venetian Plaster Flax	DSK0305 Travertine Lichen
DSK0106 Fresco Rosewood	DSK0206 Venetian Plaster Feather Grey	DSK0306 Travertine Dark Green
DSK0107 Fresco Juniper	DSK0207 Venetian Plaster Juniper	DSK0307 Travertine Pecan
DSK0109 Fresco Beaver Brown	DSK0208 Venetian Plaster Beaver Brown	DSK0308 Travertine Walnut
DSK0110 Fresco Teakwood	DSK0209 Venetian Plaster Teakwood	DSK0310 Travertine Teakwood
DSK0111 Fresco Ebony		DSK0311 Travertine Nero

**Designer Suede Mat Board • 32 x 40 (4 Ply)**

- High quality designer suede, rich in color with a dense luxurious flock
- Buffered to a pH of 8.0 to 9.5
- Conservation Core
- Clean extra thick bright white bevel

DS950 Black Suede	DS957 Royal Red Suede	DS964 Champagne Suede	DS971 Pine Suede
DS951 Navy Suede	DS958 Buckskin Suede	DS965 Dove Grey Suede	DS972 Bronze Suede
DS952 Hazelnut Suede	DS959 Latte Suede	DS966 Mint Green Suede	DS973 Sage Suede
DS953 Moss Green Suede	DS960 Chocolate Suede	DS967 Mushroom Suede	DS974 Admiral Blue
DS954 Emerald Suede	DS961 Gun Metal Suede	DS968 Slate Blue Suede	DS975 Sterling Suede
DS955 Pewter Suede	DS962 Royal Blue Suede	DS969 Gull Grey Suede	DS976 Red Rock
DS956 Bordeaux Suede	DS963 Camel Suede	DS970 White Suede	DS977 Navajo

**Designer Suede Giant Mat Board • 40 x 60 (4 Ply)**

DSG6950 Black Suede	DSG6958 Buckskin Suede
DSG6951 Navy Suede	DSG6974 Admiral Blue Suede
DSG6956 Bordeaux Suede	

**Designer Fabric Mat Board • 32 x 40 (4 Ply)**

- White high alpha cellulose core that is free of acid, lignin, and ground wood
- Fade and bleed resistant surface papers
- Buffered to an alkaline pH
- Contains no optical brighteners
- Meets all Fine Art Trade Guild and Fine Art Care & Treatment standards

DF920 Ruby Linen	DF923 Ebony Linen
DF921 Gallery Linen	DF924 Dynasty Blue Linen
DF922 Cream Linen	DF925 Brilliant White Linen

DF900 Graphite Weave
DF901 Slate Weave
DF902 Sterling Weave
DF903 Rattan Weave
DF904 Grey Weave

DF940 Shiro
DF941 Shinju
DF942 Aka
DF943 Kon
DF944 Kuro
DF945 Kaki

DF930 White Real Linen	DF934 Baja Real Linen
DF931 Snow Real Linen	DF935 Black Shadow Real Linen
DF932 Cream Real Linen	DF936 Java Real Linen
DF933 Mojave Real Linen	

**Designer Fabric Mat Board • 40 x 60 (4 Ply)**

DFG6930 White Real Linen	DFG6932 Cream Real Linen
DFG6931 Snow Real Linen	DFG6935 Black Shadow Real Linen

DFG6921 Gallery Linen
-----------------------



- 100% Cotton Fiber
- Solid color throughout
- Traditional ply construction
- Buffered with calcium carbonate
- Naturally Acid-Free
- Naturally Lignin-Free

## Museum Single Ply Mat Board • 32 x 40

M900-1 White 1 Ply

## Museum 2-Ply Mat Board • 32 x 40

M900-2 White 2 Ply

## Museum 4-Ply Mat Board • 32 x 40

M900-4 White	M903-4 Cream
M901-4 Warm White	M906-4 Soft Cream
M902-4 Traditional White	M950-4 White (unbuffered)

M904-4 Light Grey

M905-4 Black

## Museum 8-Ply Mat Board • 32 x 40

M900-8 White	M902-8 Traditional White
M901-8 Warm White	M906-8 Soft Cream

M905-8 Black

## Museum 4-Ply Giant Mat Board • 40 x 60

MG900-4 White	MG902-4 Traditional	MG906-4 Soft Cream
MG901-4 Warm White	MG903-4 Cream	

MG904-4 Light Grey

MG905-4 Black

## Museum 8-Ply Giant Mat Board • 40 x 60

MG900-8 White
MG901-8 Warm White
MG902-8 Traditional White

## Museum 4-Ply Oversize Mat Board

M90072-4 White Museum Jumbo • 48 x 72

M90096-4 White Museum Jumbo • 48 x 96

M9001044 White Museum Jumbo • 60 x 104



**Mount Board • 32 x 40**

910M 40-point Mount Board

---

920M 80-point Mount Board

---

5032 55-point Mount Board

---

5033 95-point Mount Board

**Mount Board • 40 x 60**

920G 80-point Mount Board

---

1092 95-point Mount Board

**Needlepoint Mount Board • 32 x 40**

R265-266 Needlepoint Mount Board

**Ultra Smooth 2-Sided Mount Board**

950 50-point Mount Board 32 x 40

---

951 100-point Mount Board 32 x 40

---

952 50-point Mount Board 40 x 60

---

953 100-point Mount Board 40 x 60

**Ultra Smooth Ready Mount Self-Adhesive Mount Board**

960 55-point Mount Board 32 x 40

---

961 110-point Mount Board 32 x 40

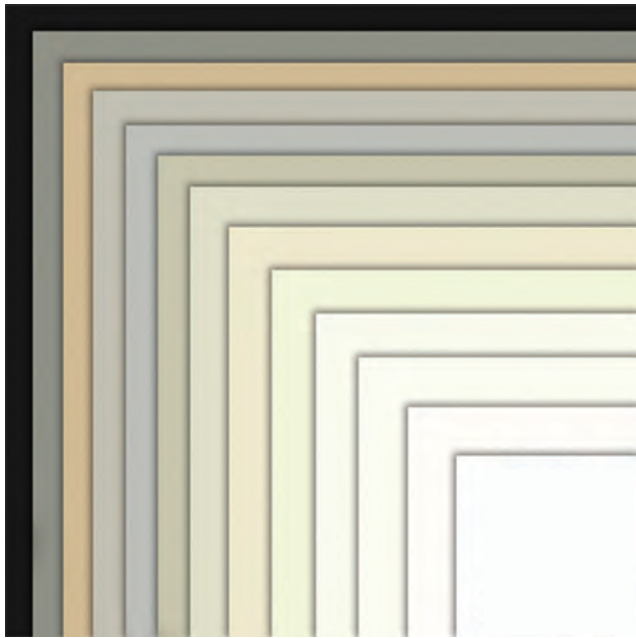

## Rising Matboards

Rising boards were created by Rising Paper over 50 years ago to supply museums' demands for a true conservation and preservation framing board. Over the years, in conjunction with Legion Paper, Rising Paper expanded the range into a family of museum boards known for its exceptional and unmatched quality. Today, under the stewardship of Legion Paper, Rising is the industry standard used to frame all the great masterpieces.

Rising is a range of acid-free museum board, conservation board and artist drawing papers used by the finest museums, galleries and framers worldwide. The Rising family of boards consists of a focused color palette of white, off-whites, greys and black to complement all works of art. The colors are solid throughout and will not fade, scuff or bleed. Rising is also the only manufacturer to offer a range of oversize boards measuring up to 60" x 104" to frame those exceptionally large pieces.

The preservation characteristics of Rising make it the ideal matting and mounting solution for fine art. Its superior cutting quality makes for an ultra-sharp and clean bevel to enhance the framed art. The rigid quality control ensures consistency across the range producing a board free of specs, dirt or blemishes. Rising exceeds the standards set by the Library of Congress.

## Rising Museum Board

Rising Museum Mounting Board is the first choice of framers, museums and conservators for the mounting, matting and preservation of fine prints and precious documents. Rising Museum Boards consist of 14 colors and manufactured with 100% cotton. The boards are acid-free, Neutral pH and buffered with calcium carbonate. Rising boards are sized for French matting and many artists use the boards for various fine art techniques such as drawing, charcoal, pastel, and silkscreening.



*The cotton used to manufacture Rising Museum Boards is not from the puffy white flower that we all recognize as cotton, but rather the linters, or byproduct, from the textile industry. Textiles are made using the longest, highest-quality fibers – the rest is discarded. This wasted cotton is salvaged and used to manufacture Rising Museum Boards. Nothing could be more eco-friendly than reusing a product that is considered waste – otherwise this would all end up in the trash.*

### • 100% Cotton

Cotton is naturally lignin-free. One hundred percent rag is used to produce all Rising Museum Board. The result is a board that provides matchless quality and extraordinary preservation characteristics. Rag papers have survived the test of time.

### • Acid Free

Rising Board is made with a minimum pH of 7 and is acid-free. No alum is used in the entire papermaking process. The single ply sheets are laminated together using an inert adhesive that is 100% acid-free and archival.

### • Buffered

All Rising boards are buffered with a minimum 3% calcium carbonate (except the Photomount papers, which have no calcium carbonate buffering) as required by the U.S. Library of Congress to protect the board from hostile environmental factors.

### • Pigments

Only the finest pigments are used in the manufacturing process to ensure that all the colors will not bleed nor fade. The lightfast colors are solid throughout and are fixed into the fiber. Each run of Museum Board is matched to a stored color sample and controlled using computerized color measurement and trained color technicians.

**• Rigid Quality Control & Consistency**  
Rising Board is continuously tested during the manufacturing process by both computer and manual controls to ensure conformance to the TAPPI and ASTM specifications required by the archival community.

### • Superior Cutting

No other board cuts as precisely as Rising to produce an ultra-sharp and clean bevel. To ensure this quality all plies are from the same quality and caliper with consistent density throughout.

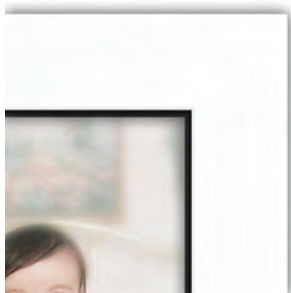

## Rising Conservation Matboard

Rising Conservation Board combines the permanence of our Rising Museum Board with the affordability of a wood pulp board. These acid and lignin-free boards are suitable for both fine art and photographic pieces. Rising Conservation Board is relatively inexpensive and designed for extended longevity.



## Rising Photomount

This non-buffered board is recommended for photographic and other uses where the usual alkaline environment of buffered mounting is considered undesirable. Since the board is not buffered, a slight drop in pH value is expected when exposed to normal atmospheric conditions.

## RISING CONSERVATION BOARD (4 PLY) • 32 x 40

R625 Ivory      R403026 White      R403126 Snow White      R403226 Antique

## RISING CONSERVATION BOARD (4 PLY) • 40 x 60

R403028 White

## RISING MUSEUM BOARD (2 PLY) • 32 x 40

R401952 White      R401953 Natural      R403198 Warm White      R405601 Antique      R405901 Polar White

R403025 White      R403125 Snow White

R401951 Medium Gray

R405630 Black

## RISING MUSEUM BOARD (2 PLY) • 40 x 60

R401755 White

## RISING MUSEUM BOARD (4 PLY) • 32 x 40

R401956 Natural      R402872 White      R405602 Antique      R405902 Polar White  
 R402447 Warm White      R405420 Ivory      R405720 Olde White      R400906 Cream

R400975 Zinc      R405620 Medium Grey  
 R405454 Fawn      R405730 Neutral Grey

R405820 Black

## RISING MUSEUM BOARD (4 PLY) • 40 x 60

R400908 Cream      R402490 White      R405721 Olde White      R405903 Polar White  
 R402487 Natural      R405603 Antique      R403196 Warm White

R400974 Zinc

R405821 Black

## RISING MUSEUM BOARD (4 PLY) • 48 x 72

R401810 White      R401820 Warm White

R402875 Black

## RISING MUSEUM BOARD (4 PLY) • 48 x 96

R401705 White      R401805 Warm White

## RISING MUSEUM BOARD (4 PLY) • 60 x 104

R401722 Antique      R402873 White      R460104 Warm White

R402874 Black

## RISING MUSEUM BOARD (8 PLY) • 32 x 40

R401700 White      R401720 Antique      R405904 Polar White  
 R401710 Warm White      R401730 Natural

## RISING MUSEUM BOARD (8 PLY) • 40 x 60

R401701 White      R401721 Antique      R405905 Polar White  
 R401711 Warm White      R401731 Natural

## RISING MUSEUM BOARD (8 PLY) • 48 x 72

R401815 White  
 R401825 Warm White

## RISING PHOTOMOUNT BOARD (4 PLY)

RPHW3240 32 x 40 4 Ply Photomount

RPHW4060 40 x 60 4 Ply Photomount



• Volume & Contract Matboard

# BERKSHIRE

Matting

## Berkshire Matboards

Berkshire matboard meets the continually evolving demand for creating framed wall décor with on trend style and sophistication that complements any art style. The Berkshire product line was specifically designed for the needs of the larger volume wall décor manufacturer. Take advantage of a palette with over 300 vivid colors and richly printed patterns – a palette that provides unparalleled creative and design flexibility. Home decor trends are constantly evolving. Designers need to be one step ahead of what's new and what's now. Berkshire products meet the growing demand for matting with a style and sophistication that complements any artwork. Berkshire brings you the latest in style and design with the industry's largest color palette, all backed by the quality of Crescent. Everything you need to make your art extraordinary.

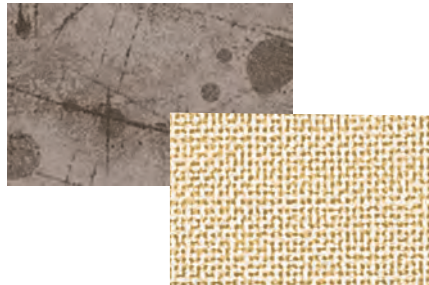
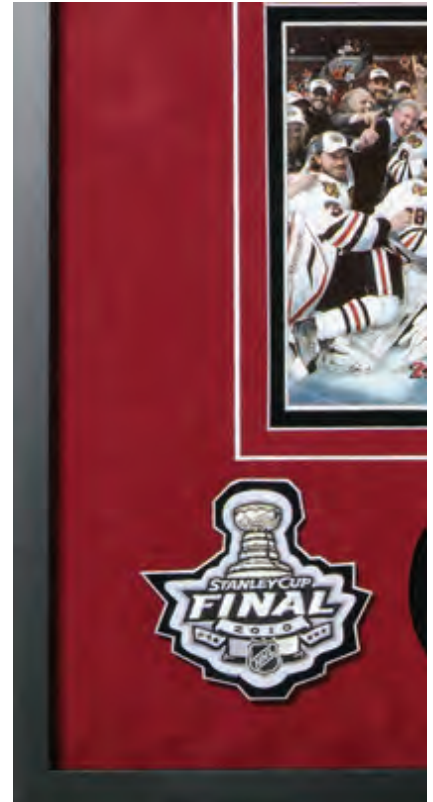

### • Color

Take advantage of a collection of over 250 vivid colors and richly printed patterns; a palette that provides unparalleled creative and design flexibility.

### • Patterns

Our innovative collection of printed and patterned matboards is unrivaled in the industry. From subtle earthy patterns to bold geometrics, you'll find an inspirational collection to add depth and texture to your framing designs.

### • Suedes

Our premium fabric surfaces feature solid white eco-core™ (100% recycled core). Available in 22 popular colors, with a richness and depth that is unmatched in the contract market. Great for sports memorabilia, as well as traditional and contemporary décor.

*at the variety  
core*

*In addition to standard cream core, Berkshire also offers the following on-trend core options:*

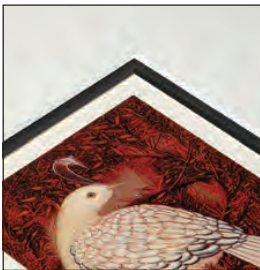

Berkshire Gallery Board

**White Core (eco-core™):** The bright white core material used on these products is comprised of 100% recycled fiber, making eco-core among the most environmentally friendly boards in the contract market. Choose from over 60 eco-core items, including solid colors, sports mats and suedes.

**Black Core:** Choose from six popular and versatile surface colors and textures, with dramatic black core for extra depth and detail.

**Gallery Board:** Get the museum look of Double Thick and Triple Thick solid color boards for the contract market. Customers will love this premium look, which is high on style at a value price.

*Be assured that every Berkshire matboard, regardless of the core material, is buffered to be pH neutral.*

• Berkshire Matboards sold only by the box (25 sheets per box)

## BERKSHIRE BASICS • 32 x 40 (4 ply)

CB038	Maroon	CB222	Smooth White	CB403	Pure White	CB524	Hunter Green
CB97	Polar White	CB334	Bottle Blue	CB461	Crisp	CBX501	Papyrus
CB221	Smooth Black	CB402	White	CB508	Ecru		
CB161	Granite	CB551	Mulberry	CB555	Burnt Sienna		

## BERKSHIRE BASICS • 33 x 42 (4 ply)

CB22142	Smooth Black
CB22242	Smooth White

## BERKSHIRE BASICS • 40 x 60 (4 ply)

CB8-038	Maroon	CB8-222	Smooth White	CB8-403	Pure White	CB8-524	Hunter Green
CB8-97	Polar White	CB8-334	Bottle Blue	CB8-461	Crisp	CB8-X501	Papyrus
CB8-221	Smooth Black	CB8-402	White	CB8-508	Ecru		

## BERKSHIRE STANDARDS • 32 x 40 (4 ply)

CB79	Yorktown Blue	CB151	Soft Pink	CB453	Dark Olive	CB523	Grass	CB569	Cinder
CB84	Grape	CB152	Tangerine	CB455	Aqua Blue	CB529	Honeydew	CB571	Pitch
CB106	Weatherwood	CB163	Oyster Shell	CB459	Deep Red	CB531	Aquamarine	CB572	Black Pebble
CB110	Buttercup	CB169	Bamboo	CB462	Glow	CB534	Fountain Blue	CB579	Sand Castle
CB115	Hazelnut	CB235	Chamois	CB473	Topaz	CB536	Clapboard	CB703	Marzipan
CB116	Monastery	CB239	Toasted Almond	CB500	Canvas	CB539	Antique Blue	CB706	Loam
CB126	French Vanilla	CB248	Sea Green	CB501	White & Cream	CB544	Cobalt	CB709	Sabbia
CB130	Silver Mist	CB251	Antique White	CB502	Cloud	CB546	Ink	CB710	Aged Oak
CB131	Midnight Blue	CB252	Cappuccino	CB504	Buff	CB547	Amethyst	CB718	Valley Green
CB132	Mojave	CB253	Pale Laurel	CB505	White & Cream Pebble	CB548	Pansy	CB752	Magnolia
CB133	Seashell	CB351	Oyster Bay	CB506	Sailcloth	CB552	Merlot	CB771	Pure Gray
CB139	Chestnut	CB357	Rattan	CB507	Soft Cream	CB558	Tawny	CB772	Dover White
CB143	Bay Blue	CB358	Dill	CB511	Beige	CB559	Fig	CB797	Beach
CB146	Sea Foam	CB361	Pistachio	CB513	Plume	CB563	Sorrel Brown		
CB147	Moss	CB404	Textured Black	CB514	Seaside	CB564	Clay		
CB148	Herbal	CB407	Cream Linen	CB516	Heritage Gray	CB567	Cobblestone		

## BERKSHIRE STANDARDS • 40 x 60 (4 ply)

CB8-106	Weatherwood	CB8-139	Chestnut	CB8-235	Chamois	CB8-459	Deep Red	CB8-558	Tawny
CB8-126	French Vanilla	CB8-146	Sea Foam	CB8-251	Antique White	CB8-502	Cloud	CB8-569	Cinder
CB8-131	Midnight Blue	CB8-163	Oyster Shell	CB8-358	Dill	CB8-514	Seaside		

## BERKSHIRE PREMIUMS • 32 x 40 (4 ply)

CB96	Alpine	CB165	Raspberry	CB522	Palm	CB538	Brittany Blue	CB557	Autumn
CB102	Hollyhock	CB350	Hay	CB525	Olive	CB540	Lagoon	CB560	Chocolate
CB120	Purple Iris	CB450	Spice	CB526	Celtic	CB541	Steel Blue	CB561	Bordeaux
CB125	Spruce	CB452	Umber	CB527	Bright Green	CB542	Blue	CB562	Dark Brown
CB127	Forest Shadow	CB464	Splash	CB528	Jade	CB545	Deep Blue	CB565	Terrazzo
CB140	Lilac	CB509	Oat	CB530	Everglade	CB549	Lavender	CB566	Felt
CB153	Brick	CB517	Dune	CB532	Reef	CB550	Cardinal	CB570	Mocha
CB155	Pumice	CB518	Pear	CB533	Ocean Blue	CB553	Bittersweet	CB700	Carnelian
CB160	Harbor	CB519	Soft Yellow	CB535	Gray	CB554	Chili	CB802	Mid Gray
CB164	Heron	CB520	Golden	CB537	Bluestone	CB556	Terra-cotta	CB803	Eclipse

## BERKSHIRE PREMIUMS • 40 x 60 (4 ply)

CB8-450	Spice	CB8-518	Pear	CB8-550	Cardinal	CB8-557	Autumn	CB8-802	Mid Gray	CB8-803	Eclipse
---------	-------	---------	------	---------	----------	---------	--------	---------	----------	---------	---------





• Berkshire Matboards sold only by the box (25 sheets per box)

## BERKSHIRE PREMIUM METALLICS • 32 x 40 (4 ply)

CB573 Graphite	CB575 Gold Foil	CB5-075 Frosted Gold
CB574 Silver Foil	CB5-074 Frosted Silver	CB5-149 Gold Relic

## BERKSHIRE PREMIUM METALLICS • 40 x 60 (4 ply)

CB85-074 Frosted Silver

## BERKSHIRE PRINTED SURFACES BASICS • 32 x 40 (4 ply)

• Decorative surface, solid cream core and backing

CB503 White Silk	CB515 Off White Silk	CB576 Gold Silk
CB512 Cream Silk	CB521 Green Silk	

## BERKSHIRE PRINTED SURFACES STANDARDS • 32 x 40 (4 ply)

• Decorative surface, solid cream core and backing

CB7-119 Rust	CB7-154 Taupe	CB7-163 Loden	CB7-174 Bronze
CB7-120 Brown	CB7-155 Brown	CB7-167 Cream	CB7-175 Khaki
CB7-150 Off White	CB7-156 Charcoal	CB7-169 Sauterne	CB7-713 Inca Gold
CB7-151 Cream	CB7-162 Sand	CB7-173 Olive	CB7-721 Tuscano

CB7-245 Bruxelles  
 CB7-246 Antwerpen  
 CB7-700 Lounge (29 1/2" X 40")

## BERKSHIRE PRINTED SURFACES PREMIUMS • 32 x 40 (4 ply)

• Decorative surface, solid cream core and backing

CB7-198 Distressed - Gold	CB7-277 Morocco Black	CB7-437 Casa Blanca Brown	CB7-443 Sea Glass Beryl
CB7-254 Sheer Silk - Sand	CB7-278 Morocco Mulberry	CB7-439 Casa Blanca Ivory	CB7-725 Burnished Metals-Bronze Plated
CB7-255 Sheer Silk - Warm Green	CB7-400 Burl	CB7-440 Sea Glass Ice	CB67-400 Burl (Black Core)
CB7-274 Empire Stripes Black	CB7-401 Maple	CB7-441 Sea Glass Milk	
CB7-276 Empire Stripes White	CB7-436 Casa Blanca Black		

## BERKSHIRE LINENS • 32 x 40

CB7-284 White Linen	CB7-288 Navy Linen
CB7-285 Khaki Linen	CB7-289 Green Linen
CB7-286 Brown Linen	CB7-290 Burgundy Linen
CB7-287 Black Linen	

## BERKSHIRE LINENS • 40 x 60

CB87-245 Antwerpen	CB87-286 Brown Linen
CB87-246 Bruxelles	CB87-287 Black Linen
CB87-284 White Linen	

## BERKSHIRE GALLERY BOARD • Double Thick (.090) 32 x 40

• Extra thick, solid color throughout

CB90B Black - DT (.090)
CB90C Cream - DT (.090)
CBSRM90 White - DT (.090)

## BERKSHIRE GALLERY BOARD • Triple Thick (.130) 32 x 40

• Extra thick, solid color throughout

CB130B Black - TT (.130)
CB130C Cream - TT (.130)
CBSRM130 White - TT (.130)

## BERKSHIRE GALLERY BOARD • Double Thick (.090) 40 x 60

• Extra thick, solid color throughout

CBSRM890 White - DT (.090)	CB890C Cream - DT (.090)
----------------------------	--------------------------

• *Volume & Contract Matboard*

• *Berkshire Matboards sold only by the box (25 sheets per box)*

## BERKSHIRE SPORTS MATS • 32 x 40 (4 ply)

• *Decorative dimensional surface, complementary core and backing*

CB62-100 Basketball (black core)    CB62-103 Gloss Black (black core)  
 CB62-101 Football (black core)    CBW2-102 Golf Ball (white core)

## BERKSHIRE WHITE CORE PREMIUM SUEDE • 32 x 40 (4 ply)

• *Fabric surface, solid white core and backing*

CB9-124 Royal Blue	CB9-130 Pine	CB9-136 Firelight	CB9-142 Night Sky
CB9-125 Winter	CB9-131 Downpour	CB9-137 Thicket	CB9-143 Cocoa
CB9-126 Grassland	CB9-132 Brook	CB9-138 Prairie	CB9-144 Sunrise
CB9-127 Leaf	CB9-133 Torrent	CB9-139 Twig	CB9-145 Clementine
CB9-128 Grove	CB9-134 Berry	CB9-140 Smoke	CB9-146 Red Sky
CB9-129 Treeline	CB9-135 Blaze	CB9-141 Ash	CB9-148 Crocus

## BERKSHIRE WHITE CORE PREMIUM SUEDE • 40 x 60 (4 ply)

• *Fabric surface, solid white core and backing*

CB89-129 Treeline	CB89-141 Ash
CB89-133 Torrent	CB89-142 Night Sky
CB89-135 Blaze	
CB89-137 Thicket	



### Hampton Matboards

Hampton Matboards has been developed from 100 years of Matboard experience and expertise. This understanding has allowed us to provide products specially designed for high-volume users at prices that remain globally competitive. Hampton is a cost effective choice for those who desire high-quality, clean results and a board that is easy to handle. Made with a buffered alkaline pH this sturdy board creates a crisp and smooth finish that lasts. Featuring even color coverage, Hampton Matboard is available in a range of popular mounting colors to match the look you're after. A great option for those larger jobs that require an efficient, reliable and affordable solution.



- *Bright White Core*
- *Easy-to-cut, producing a crisp clean bevel*
- *Buffered to an alkaline pH (7.5 to 9.5)*
- *High quality surface papers with smooth even coloration*
- *50 point (1.2mm) thick*
- *32" x 40" (812 x 1016mm)*
- *40" x 60" (1016 x 1524mm) now available*
- *Hampton Matboards are available in 34 popular colours sized 32"x40", and in both whitecore and regular cream core.*
- *Fully customized runs available (thickness, length).*
- *Also can be cut to size, in 25 sheet boxes, or bulk on a skid.*

**Hampton Matboards • A great value for volume Picture Framers**

## HAMPTON MATBOARD • 32 x 40

H3000	Ultimate White	H3004	China White
H3001	Plain White	H3005	Sand Stone
H3002	Old White	H3100	Jet Black
H3003	Bone		

## HAMPTON MATBOARD • 32 x 40

H3099	Natural Parchment	H3300	Pine	H3403	Dolphin	H3501	Wine
H3101	Shell	H3301	Slate	H3405	Espresso	H3502	Fire
H3102	Deep Grey	H3302	Cricket Green	H3406	Plaster	H3600	Straw
H3103	Flagstone	H3303	Sea Foam	H3407	Concrete		
H3104	Blue Grey	H3304	Sage	H3408	Hazelnut		
H3200	Navy Blue	H3400	Dark Chocolate	H3409	Putty		
H3202	Slate Blue	H3401	Light Sand	H3410	Desert		
H3203	Royal Blue	H3402	Pebble	H3500	Red		

## HAMPTON SUEDE MATBOARD • 32 x 40

HS7600	Coal Suede	HS7603	Golf Green Suede	HS7606	Fawn Suede
HS7601	Cobalt Suede	HS7604	Burgundy Suede	HS7607	Dark Blue Suede
HS7602	Doe Suede	HS7605	Red Suede		

# OMEGA

## VOLUME & CONTRACT MATBOARD

Sold by the box only (volume mat line)

Acid Free • White Core

## OMEGA MATBOARD • 32 x 40

1 Box/ 25 sheets

OMM5000	Snow White	OMM5100	Coal Black	OMM5500	Red
OMM5001	Pearl White	OMM5200	Navy Blue	OMM5501	Merlot
OMM5002	Antique Ivory	OMM5302	Deep Moss	OMM5600	Sunshine
OMM5005	Vanilla Cream	OMM5400	Mocha		

Acid Free • White Core

## OMEGA SUEDE MATBOARD • 32 x 40

1 Box/ 25 sheets

OMS7600	Black Suede
---------	-------------



## A

Abaca.sa Hinging Tape	10
Acid-Free Backing Paper - <i>Lineco</i>	11
Acid-Free Drymount Tissue	12
Acid-Free Foam Board	1-3
Acid-Free Framing Tape	9, 10
Acrylate Adhesive	16
<b>Acrylic</b>	
Acrylic Cleaner	5
Acrylic object mounts	39
Acrylic Scratch Remover	6
Acrylite Acrylic	5
Adhesive bumpers	38
Adhesive hanger for foam board	38
Adhesive Release	16
Adhesive Remover	16
<b>Adhesive Sprays</b>	15
Adjustable Offset Picture Hanger	26
Adjustable Temperature Tacking Iron	14
All Purpose Mounting Glue	16
All-In-One Kraft Paper Dispensers	44
Amaco Nail Hole & Corner Filler	35
Anchors, screws	30
Angled Hangers, Takiya	27
Antiquing Medium, glaze (Z-Crackle)	36
Anti-Static Brush, grounded	40
Anti-Static cleaning cloth	40
Archival Encapsulation Film	14
<b>Archival Framing Tapes</b>	10
Archival Mounting Strips	11
Archival Polyester Mounting Corners	11
Art sleeves	45
Artcare Foam Board	3
<b>Artglass</b>	4
Articulated Angles ( <i>metal frame hardware</i> )	31
ArtShield UV Laminating Films	13
Artwork cleaning	40
<b>ATG Tape</b>	7
ATG Applicator Guns	7

## B

<b>Backing Paper</b>	11, 44
Backing Paper Dispensers	44
Backing Paper Trimmers	19
Bainbridge Artcare Foam Board	3
Bainbridge Newsboard	46
Bear Claw Hanger	33
Beveled Mirror	6
Bienfang Perforator	14
Black Acid Free Foam Board	1, 2
Black Baron Tacking Iron	14
Black Flocked Tape	8
Black Foam Board	1, 2
Black Kraft Paper	44
<b>Black Magic</b> Black Wood Glue	16
Black Masking Tape	9
<b>Blades - Mat Cutting &amp; General Use</b>	19-20
Blades for Hobby Knives	20
Blades for Utility Knives	20
Blades, Mat Cutting	19, 67
Blades, XACTO	20
Board Cutting Blades, <i>Foster Keencut</i>	66
Bone Folder	39
Books, educational/instructional	49
Box Sealing Tape	8
Braces for crating, transport	28
Brackets for hanging support	26
Brad Nails for Pneumatic Drivers	24
Braided Picture Wire	17-18
Brass Gallery Rod System, parts	34
Brass Picture Hooks	33
Brush 'N Leaf	35
Bubble Bags	46
Bubble Corner Pads	46
Bubble with Kraft Backer	47
Bubble Wrap (by the roll)	47
Buffermount tissue - <i>D&amp;K</i>	12
Bulk Foam Board	2
<b>Bumpers</b> , adhesive bump-ons	38
Burnishing Bone	39

## C

C+H Mat Cutters	64
C+H Mat Cutting Blades (#1200 & #1500)	19
C+H Vertical Wall Cutter	64
Cable, for Takiya hanging system	25
Canvas hangers	38
<b>Canvas Stretcher Bars</b>	48
Canvas Stretching Machines	51
Canvas Stretching Pliers	39
Carbide Glass Wheel, <i>Foster Keencut</i>	66
<b>Cardboard</b>	46
Cardboard Corners	46
Cassese cartridged wedges	21
Chartpak Touch-Up Markers	34
Chevrons, hook/velcro self adhesive	47
Chip Breakers	42
Clamp, Joining	24
Clean Jet 100, Dust Remover	40
Cleaning Brush	40
Cleaning Cloths, wipes	40-41
Cleaning Pad	40
Cleat hanger	34
Coated Wire	17, 18
ColorMount dry mounting tissue	12
Composite Twin Wheel Cutting Head	66
Compressors	59
Computerized Mat Cutters	61-62
Conservation Framing Tapes	10
<b>Conservation Tapes, Adhesives</b>	10-11
Corner Angles (hardware)	33
Corner Hardware, metal frames	31
<b>Corner Nails</b>	21
Corner Pads	46
Corner Protectors	46
Corner Vise	24
Corner Weld Polyvinyl Glue	16
Corrugated Cardboard	46
Corrugated Plastic (Polypropylene)	3
Cotton Gloves	40
Courtesy Picture Hooks	33
Crepe Masking Tape	9
Cutting Head unit, <i>Foster Keencut</i>	66
Cutting Mats, self-healing surface	43

## D

D&K Expression Products	12, 13, 14
D&K UV Laminating Films	13
De-roller - D&K	14
Dexter Mat Cutter	19
Dexter Style Mat Cutter Blades	19
Diamantor Glass Cutter	42
Digital Printing DVDs	50
Dispensers, Kraft	44
Display Rack	45
Document Cleaning Pad	40
Double Miter Saws	54-55
Double-Head Bear Claw Hanger	33
Double-Sided Tape for Fabric	9
<b>D-rings</b>	27, 29
D-rings, angled	27
D-rings, Takiya	27
Dry Mounting Products	12-14
Dry Mounting Release Board	13
Dry Mounting Release Film	13
Dry Mounting Release Paper	12-13
Drymount hangers	38
<b>Drymount Tissue</b>	12
Drymounting Press	52
Drytac Products	12, 13
Drytac Hot/Cold Vacuum Press	52
Drytac Laminating Films	13
Dust Collectors	56
Dust remover	40
Dusting Brush	40
DVDs, educational media	50

## E

Earthquake hangers	26, 27, 28, 30
<b>Easel Backs</b>	36
Easy-Fit Nylon Coated Wire	17
Econospace	37
<b>Educational Media</b>	49, 50
Elmers Adhesive Products	15
Embossed Easel Backs	36
Encapsulation Film	14
Encore Foam Board	1
Euro Hanger ( <i>metal frame hanger</i> )	31
Excalibur vertical cutters, <i>Foster Keencut</i>	65
Excalibur 5000 Cutting Head	66

## F

Fabric Adhesive	16
Filament Tape	8
Filmoplast	10
<b>Fitting &amp; Backing Supplies</b>	36-38
Flangers	29
Flat Back Tape	8
<b>Flexpoints</b> , Flexible Framing Points	22
Flobond Dry Mounting Film - <i>Drytac</i>	12
Flocked Tape	8
Foam & Mat Board Storage Cart	43, 68
<b>Foam Board</b>	1-3
Foam Board cutting, wall cutters	64-65
Foam Overlay for laminating materials	13
Foam Padding (by the roll)	47
Folding Bell Hangers	28
Folding Shipping Braces	28
Foster Keencut accessories, parts	66-67
Foster Keencut blades	19, 66, 67
Foster Keencut Vertical Cutters	65
Frame Backer Paper - <i>Lineco</i>	11
Frame Clamp, belt	24
Frame Hardware, hangers	25-34
Frame Joining, vise, clamp	24
Frame Sealing Tapes - <i>Lineco</i>	11
Frame Touch-Up	34-35
Frame Wire Clips	28
Framer's Glue	16
Framers Mounting Corners - <i>Lineco</i>	11
Framer's Point Drivers	23
Framers Tape II	9
Framer's Vise	24
Framespace	37
Framing media, educational	49-50
Framing Points	22
Fusion 4000 dry mounting tissue	12

## G

Gaffers Tape - Black	8
<b>Gallery Hanging &amp; Display Products</b>	45
Gallery Rod system, parts	34
<b>Glass</b>	
Glass Breaking Pliers	42
Glass Cleaner	6
Glass Cutter, hand tool	42
Glass cutting cartridge, <i>Foster Keencut</i>	66
Glass Cutting, vertical wall cutters	64-65
Glass scoring wheel, <i>Foster Keencut</i>	66
Gloves, artwork handling	40
Gloves, for handling glass	42
Glue - Fabric Mounting	16
Glue - <i>joining wood moulding</i>	16
Glue - <i>joining polystyrene moulding</i>	16
Glue for mounting in vacuum press	16
Glue Gun	43
Glue Sticks	43
<b>Glues &amp; Adhesives</b>	15-16
Gold, gilding touch-up materials	35

## H

Hand Miter Cutter	42
Hand-held mat cutter	19
<b>Hangers</b> (hardware)	25-34
Hangers for metal frames	31
Hangers for Takiya hanging system	25
Hanging Cable for Takiya system	25
Hanging Rails, for Takiya system	25
Hanging Support Brackets	26
Hangman Products	38
Hardpoints	22
<b>Hardware</b>	25-34
HartBoard	2
Hartman Products	2
Hassle-Free Trim Tool	19
<b>Heat Activated Foam Board</b>	1, 2, 3
Heat Mounting Press	52
<b>Heat Mounting Products</b>	12-14
Heavy duty wall hanger, Hangman	38
Hinging Tape	9-10
Hobby Knives & Blades	20
<b>Hook &amp; Loop</b> , self adhesive	47
Hook Chevrons, self adhesive	47
<b>Hooks</b>	25, 26, 27, 28, 33
Hooks, Takiya	25-26, 27
Hot Melt Glue Gun	43
Hot Melt Glue Sticks	43
Hot/Cold Vacuum Press	52

## I

Inmes Dust Collectors	56
Inmes Miter Saws	53-55
Inmes Underpinners	57-58
Inmes Universal V-Pins	21

## K

Kinetronics Static Discharge Brush	40
Kool Tack Foam Board	2
<b>Kraft Paper &amp; Dispensers</b>	44
KWIK Hangers, for foam board	38

## L

Laminating Films	13
Lamination Machine, D&K EXP42	51
Lineco Products	10-11
Linen Hinging Tape	10
Liquid Leaf	35
Logan Mat Cutting Blades	19
Loop Fabric	47

## M

<b>Machinery</b>	51-68
Magic Tape	8
Manual mat cutter	19
Markers, touch-up	34
Masking Tape	9
Master Clamp	24
Mat Blades	19
Mat Blades, <i>Foster Keencut</i>	67
Mat Board Storage Unit	43, 68
<b>Mat Boards</b>	69-94
<b>Mat Cutters</b>	61-67
Mending Plates (hardware)	33
Mending Tissue	10
Metal Frame joining hardware	31
Metal Frame security hanging hardware	30
Metal Frames, hardware for	30, 31
Metal Rulers, straight edge	39, 68
Microfiber Cloths	40
Mighty Mounts	39
Mirror Tape - Black	8
<b>Mirrors</b>	
Miter Cutter hand tool	42

**M - continued**

Miter Disc Sander 53  
 Miter Fusion - acrylate adhesive 16  
 Miter Magic - polyvinyl glue 16  
**Miter Saws** 53-55  
**Miter Vise** 24  
 Moulding Hooks 33  
 Moulding joining, vise, clamp 24  
 Mountable Kraft Paper Dispensers 44  
 Mounting Spray Adhesives 15  
**Mounting & Hanging Supplies** 38-39  
 Mounting Corners - Lineco 11  
 Mounting Glue - Vacuum Press 16  
 Mounting Strips - Lineco 11  
**Mounting Tissues & Release Boards** 12-14  
 M-Tork cleaning towels, dispenser 41  
 Multiple Function Wall Hook 26  
 MuSE by Takiya 25

**N**

**Nail Hole & Corner Filler** 35  
 Neschen Products 10  
 Newsboard 46  
 No-Lint wipes 41  
**Non-Glare Glass** 4  
 Novus Acrylic Products 6  
 Nylon Coated Wire 17, 18

**O**

Object mounts 39  
**Offset Clips** 32  
 Offset Wall Hanger/Hook 26  
 Omega Cleat Hanging System 34  
 Omega Drymounting Release Paper 13  
 Omega Foam Board 2  
 Omega Framing Points 22  
 Omega Dry Mount Tissue 12  
 Omega Silicone Release Film 13  
 Omer Flexible Framing Points 22  
 Omer Hard Framing Points 22

**P**

Packaging Tape 8  
**Packing Materials & Supplies** 46  
 Paper Roll Dispensers 44  
 Pen Knife - XACTO 20  
 pH Neutral Adhesive - Lineco 11  
 Phenolic Chip Breaker 42  
 Phenolic Scrap Support 42  
 Photo Corners - Lineco 11  
 Picture Framing educational media 49-50  
**Picture Hanging Hardware & Fasteners** 25  
**Picture Hooks** 33  
 Picture Hooks, bulk 33  
**Picture Wire** 17-18  
 Pistorius Saws, chip breakers 42  
 Pistorius Saws, scrap supports 42  
 Pistorius Underpinners - Nails 21  
 Plastic Bag Roll Dispensers 44  
**Plastic Bags** (by the roll) 46  
 Plastic Scratch Remover 6  
 Plastic Sleeves 45  
 Plastic spacers 37  
 Plastic Stretch Wrap (roll) 47  
 Plastic Stretch Wrap (wand) 47  
 Pliers for glass breaking (glass snips) 42  
 PMA - Positionable Mounting Adhesive 14  
 Pneumatic Brad Nailers 23  
**Pneumatic Framing Points** 22  
**Pneumatic Point Drivers** 23

**P - continued**

Pneumatic Staple Guns 23-24  
 Pneumatic Underpinners 57-58  
**Point Drivers** 23  
**Points** 22  
 Polyvinyl Glue 16  
 Positionable Mounting Adhesive 14  
 Premium Canvas Pliers, Fredrix 39  
 Premium Strap Hangers 27  
 Print Display Rack 45  
 Print Holders 45  
 Print sleeves 45  
 Professional Trimming Tool (for backing) 19  
 Putnam/AMP Underpinners - Nails 21  
 Putty, nail hole & corner filler 35

**R**

Rabbit Tape - Lineco 11  
 Rabbitspace 37  
 Ragmount Dry Mounting Tissue - D&K 12  
 Rails, for Takiya hanging system 25  
**Razor Blades** 19  
 Reflection Control Acrylic 5  
 Reflection Control Glass 4  
 Regular Glass 4  
**Release Board** 12, 13  
**Release Paper** 12, 13  
 Removable Tape 8  
 Repositionable 75 Spray Adhesive - 3M 15  
 Retractable Utility Knife 20  
 Rigid Framing Points 22  
 Rotating Miter Saws 53  
 Router Bits for C+H Thumbnailer 22, 51  
 Rub 'N Buff 35  
 Rulers 39

**S**

Safety Glasses 54  
 Sanding Discs, 3M 53  
 Saw Blades 55  
 Saw Cleaner 54  
 Sawdust Collectors 56  
 Sawtooth hangers 32  
 Scissors, pro grade 39  
 Scotch Positionable Mounting Adhesive 14  
 Scotch Tapes, 3M 8  
 Scrap Supports 42  
 Screw Eyes 32  
**Screws** 32  
 Sealant, Silicone 15  
 Security Hardware by Takiya 26  
**Security Hardware**, hanging 26, 30  
 Security Hooks, floret style 27  
 Self-healing Cutting Mats 43  
 Senco Products 23, 24  
 Senco Staples, Brads 24  
 Shadow-box framing, object mounts 39  
 Shipping Braces 28  
 Shrink Wrap 47  
 Shrink Wrap Machine, Traco 40" 51  
 Sightline Strips, Foster Keencut 66  
 Silicone Release Board 13  
 Single Step Foam Board 1  
 Slotted Security Plate (security hardware) 30  
 Snap Blade Utility Knife 20  
 Snap Blades 20  
 Snap Hangers (metal frame hardware) 31  
 SoftStrand Stainless Steel Wire 17  
 Spacemaker 37  
**Spacers** 37  
 Specialty Glass 4-5  
 Specialty Hanging Systems 25-28  
**Specialty Tools & Cleaning Items** 39-43  
 Specialty Wall Hooks/Hangers 25-28, 30  
 Speck Grabber 40

**S - Continued**

SpeedMount Foam Board 3  
 Spray Adhesives 15  
 Sprayway Adhesive Spray 15  
 Sprayway Glass & Acrylic Cleaners 6  
 Sprayway Lint & Dust Remover 40  
 Sprayway Saw Cleaner 54  
 Spring Clips (metal frame hardware) 31  
 Stainless Steel Wire 17  
 Standoff Hardware 45  
 Staples 24  
 Static Discharge Brush 40  
 Steel Hangers 29  
 Stick-on hangers for foam board 38  
 Stitchery Tape 9  
 Storage Unit for mat boards 43, 68  
 Straight Edges 39, 68  
 Straight Edges, laser trued 68  
 Strap Hangers 27, 29  
 Strap Hangers, Takiya 27  
 Stretch Wrap (roll) 47  
 Stretch Wrap (wand) 47  
**Stretcher Bars** 48  
 Substrate cutters, vertical 64-65  
 Super Shears 39  
 Super SoftStrand 17  
 Support Brackets, hang weight support 26  
 Surflon Crimping Pliers 18  
 Surflon Crimping Sleeves 18  
 Surflon Wire System 18  
 Swiss Clips 38

**T**

Table Top Kraft Dispensers 44  
 Tacking Irons 14  
**Takiya products** 25-28  
 Tape Measure 39  
**Tapes, Adhesives, & Mounting Supplies** 7-9  
 Tapped Angles (metal frame hardware) 31  
 T-Clip Flush Hangers 28  
 Tensador Canvas Stretching Machines 51  
 Thumbnail Joining Inserts 22  
 Thumbnail Master Router, C+H 51  
 Tiger Cloth, anti-static cloth 40  
 Tissue Perforator 14  
**Touch-Up & Fillers** 34-35  
 Traco Shrink Wrap Machine, 40" 51  
 Treasure Gold 35  
 Trimming Tool for Backing Paper 19  
 TriMount Dry Mounting Tissue - Drytac 12  
 Tru Vue Premium Glass Cleaner 6  
 T-screw (security hardware) 30  
 Turnbuttons 33  
 Twin-Wheel Cutting Head, Foster Keencut 66  
 Tyvek Backing Paper - Lineco 11

**U**

Ultimat Series Mat Cutters, Foster Keencut 67  
 Ultimo II Storage Cart for Mat Board 43  
 Underpinner V-Nails 21  
**Underpinners** 57-58  
 Un-du Adhesive Remover 16  
 UnStik Adhesive Release 16  
 Utility Knife Blades 20  
**Utility Knives** 20  
 UV Laminating Films 13  
**UV Protection Glass** 4, 5

**V**

VacuGlue 300 16  
 Vacuum Press 52  
 Valiani Mat Cutters 61-63  
 Variguard Smart Glass 5  
 Velcro 47  
 Velour Easel Backs 36  
 Vertical Kraft Paper Dispensers 44  
**Vise** 24  
 VistaMount Mounting Tissue - Drytac 12  
 Vivian Kistler books & videos 49-50  
**V-Nails** 21  
 Volara Foam Rabbit Tape - Lineco 11

**W**

Wall bracket (security hardware) 30  
 Wall bracket, cleat hanger 34  
**Wall Cutters**, substrate/board/glass 64-65  
 Wall Hooks 27, 33  
 Wall Hooks, Takiya 26, 27  
 Wall mounted Support Brackets 26  
 Water White Glass 4  
 Weight Support, wall hanging 26  
 White Glue 16  
 Wire Brads 32  
 Wire Caddy 17  
 Wire Clips 28  
**Wire Products** 17-18  
 Wood Frame Security Hardware 26, 30  
 Wypall cleaning wipes 41

**X-Z**

XACTO Products 20  
 Z-Cleat, hanging bars 34  
 Z-Crackle 36  
 Z-Gel 36  
 Zig-Zag plastic foamboard hanger 38

**ΩMEGA<sup>+</sup>**

QUALITY FRAMING PRODUCTS

51 Terecar Dr. Unit 3 • Woodbridge, ON L4L 0B5

SERVING THE FRAMING INDUSTRY OVER 45 YEARS



Telephone: 1-877-452-3799 • Fax: 1-877-452-3783 • Web: [www.omegamoulding.ca](http://www.omegamoulding.ca)